

Operating Manual

SERIES MRR / MRA

Incremental encoded elastomer-based Magnetic Rings



- Magnetic rings in radial (MRR) or axial (MRA) construction
- Suitable for a wide range of ELGO incremental sensors as well as for the battery-powered measuring and display systems of the IZ series
- Bearing-less rotary encoders with non-contact, wear-free scanning
- Three different pole lengths available (2 / 2.5 / 5 mm)
- Thanks to protection class IP68 predestined for outdoor use
- Resistant to thermal, chemical and mechanical influences
- Suitable for difficult environmental conditions

Publisher ELGO Electronic GmbH & Co. KG
Carl-Benz-Str. 1
D-78239 Rielasingen-Worblingen

Technical Support  +49 (0) 7731 9339 - 0
 +49 (0) 7731 2 88 03
 info@elgo.de

Document- No. 799000912

Document- Name MRR-MRA-00-MA-E_05-22

Document- Revision Rev. 2

Issue Date 2022-01-31

Copyright © 2022, ELGO Electronic GmbH & Co. KG

1 Contents

1	Contents	3
2	List of Figures	4
3	General, Safety, Transport and Storage	5
3.1	Information Operating Manual	5
3.2	Explanation of Symbols	5
3.3	Statement of Warranties	6
3.4	Demounting and Disposal	6
3.5	General Causes of Risk.....	6
3.6	Personal Protective Equipment.....	6
3.7	Conventional Use	7
3.8	Safety Instructions for Transport, Unpacking and Loading	7
3.9	Handling of Packaging Material	7
3.10	Inspection of Transport	7
3.11	Storage	7
4	Product Features	8
4.1	Special Features	8
4.2	Pole Pitches and compatible Sensors	8
4.3	Radial Magnetic Rings (MRR)	8
4.4	Axial Magnetic Rings (MRA)	8
5	Technical Data and Variants	9
5.1	General Technical Data	9
5.2	Type-Specific Data	9
5.3	System Resolution including Sensor	10
6	Installation.....	12
6.1	Mounting on the Axis or Shaft	12
6.2	Alignment of the different Sensor Types.....	15
7	Maintenance and Cleaning	21
7.1	Maintenance.....	21
7.2	Cleaning	21
8	Type Designation	22
8.1	Accessories	22
9	Index	23

2 List of Figures

Figure 1: Magnetic Rings MRR	8
Figure 2: Magnetic Rings MRA	8
Figure 3: Dimensions MRR	10
Figure 4: Dimensions MRA	10
Figure 5: Fitting or bonding to shaft or shaft shoulder	13
Figure 6: Mounting with a flange or blind flange	13
Figure 7: Fitting or bonding to a shaft shoulder	14
Figure 8: Bonding into a front profile recess	14
Figure 9: Alignment of LMIX1, EMIX1, GMIX1A and Series IZ	15
Figure 10: LMIX2 / EMIX2 alignment with MRR	16
Figure 11: LMIX2 / EMIX2 alignment with MRA	17
Figure 12: Position of the active sensor areas with LMIX22 / EMIX23	18
Figure 13: Alignment of LMIX22 / EMIX23 (option R)	18
Figure 14: Alignment of GMIX2	19
Figure 15: Alignment of RMIX2	20
Figure 16: Alignment of KMIX2	21

3 General, Safety, Transport and Storage

3.1 Information Operating Manual



This manual contains important information regarding the handling of the device. For your own safety and operational safety, please observe all safety warnings and instructions. Precondition for safe operation is the compliance with the specified safety and handling instructions. Moreover, the existing local accident prevention regulations and the general safety rules at the site of operation have to be observed.

Please read the operating manual carefully before starting to work with the device! It is part of the product and should be kept close to the device and accessible for the staff at any time. The illustrations in the manual are for better demonstration of the facts. They are not necessarily to scale and can slightly differ from the actual design.

3.2 Explanation of Symbols

Special notes in this manual are characterized by symbols. The notes are introduced by signal words which express the magnitude of danger. Please follow this advice and act carefully in order to avoid accidents, damage, and injuries.

Warning notes:

	DANGER! This symbol in connection with the signal word "Danger" indicates an immediate danger for the life and health of persons. Failure to heed these instructions can result in serious damage to health and even fatal injury.
	WARNING! This symbol in connection with the word „Warning“ means a possibly impending danger for the life and health of persons. Failure to heed these instructions can result in serious damage to health and even fatal injury.
	CAUTION! This symbol in connection with the signal word "Caution" indicates a possibly dangerous situation. Failure to heed these instructions can lead to minor injuries or damage of property.



Special safety instructions:

	DANGER! This symbol in connection with the signal word "Danger" indicates an immediate danger for the life and health of persons due to voltage. Failure to heed these instructions can result in serious damage to health and even fatal injury. The operations may only be carried out by a professional electrician.
---	---

Tips and recommendations:

	NOTE! ...points out useful tips and recommendations as well as information for an efficient and trouble-free operation.
---	---

Reference marks:

-  Marks a reference to another chapter of this manual.
-  Marks a reference to another chapter of another document.

3.3 Statement of Warranties

The producer guarantees the functional capability of the process engineering and the selected parameters.

3.4 Demounting and Disposal

Unless acceptance and disposal of returned goods are agreed upon, demount the device considering the safety instructions of this manual and dispose it with respect to the environment.

Before demounting, disconnect the power supply and secure against re-start. Then disconnect the supply lines physically and discharge remaining energy. Remove operational supplies and other material.

Disposal: Recycle the decomposed elements: Metal components in scrap metal, Electronic components in electronic scrap, Recycle plastic components, dispose the remaining components according to their material consistence.



CAUTION!

Wrong disposal causes environmental damages! Electronic scrap, electronic components, lubricants and other auxiliary materials are subject to special refuse and can only be disposed by authorized specialists!

Local authorities and waste management facilities provide information about environmentally sound disposal.

Safety



CAUTION!

Please read the operating manual carefully, before using the device! Observe the installation instructions! Only start up the device if you have understood the operating manual. The operating company is obliged to take appropriate safety measure. The initial operation may only be performed by qualified and trained staff. Selection and installation of the devices as well as their embedding into the controlling system require qualified knowledge of the applicable laws and normative requirements on the part of the machine manufacturer.

3.5 General Causes of Risk

This chapter gives an overview of all important safety aspects to guarantee an optimal protection of employees and a safe and trouble-free operation. Non-observance of the instructions mentioned in this operating manual can result in hazardous situations.

3.6 Personal Protective Equipment

Employees have to wear protective clothing during the installation of the device to minimize danger of health.

Therefore:

Change into protective clothing before performing the works and wear them throughout the process. Additionally observe the labels regarding protective clothing in the operating area.

Protective clothing:

	<p>PROTECTIVE CLOTHING</p> <p>... is close-fitting working clothing with light tear strength, tight sleeves and without distant parts. It serves primarily for protection against being gripped by flexible machine parts. Do not wear rings, necklaces or other jewelry.</p>
	<p>PROTECTIVE GLOVES</p> <p>...for protecting the hands against abrasion, wear and other injury of the skin.</p>
	<p>PROTECTIVE HELMET</p> <p>...for protection against injuries of the head.</p>

3.7 Conventional Use

The ELGO product is designed exclusively for the intended use described here:
The magnetic rings of the MRR / MRA series are used exclusively for incremental measurement of rotative movements.

**CAUTION! Danger through non-conventional use!**

Non-intended use and non-observance of this operating manual can lead to dangerous situations.
Therefore:

- Only use the device as described
- Strictly follow the instructions of this manual

Avoid in particular:

- Remodeling, refitting or changing of the construction or single components with the intention to alter the functionality or scope of the device.

Claims resulting from damages due to non-conventional use are not possible.
Only the operator is liable for damages caused by non-conventional use.

3.8 Safety Instructions for Transport, Unpacking and Loading

**CAUTION!**

Transport the package (box, palette etc.) professionally. Do not throw, hit or fold it.

3.9 Handling of Packaging Material

Notes for proper disposal: ☞ 3.4

3.10 Inspection of Transport

Check the delivery immediately after the receipt for completeness and transport damage.
In case of externally recognizable transport damages:

- Do not accept the delivery or only accept under reserve.
- Note the extent of damages on the transportation documents or delivery note.
- File complaint immediately.

**NOTE!**

Claim any damage immediately after recognizing it.
The claims for damage must be filed in the lawful reclaim periods.

3.11 Storage

Store the device only under the following conditions:

- Do not store outside
- Keep dry and dust-free
- Do not expose to aggressive media
- Protect from direct sun light
- Avoid mechanical shocks
- Storage temperature (☞ 5.1) needs to be observed
- Relative humidity (☞ 5.1) must not be exceeded
- Inspect packages regularly if stored for an extensive period of time (>3 months)

4 Product Features

By using magnetic rings, the considerable advantages of the magnetic measuring principle can also be used for rotary movements. Magnetic rings are used wherever movements, speed and direction of rotation as well as acceleration or positions such as angle and circumference of shafts have to be measured, monitored or controlled. The measurement or scanning is contactless and therefore completely wear-free.

The bearing less magnetic rings represent a space saving alternative to optical rotary encoders, which are also insensitive to dirt, dust, liquids, vibrations and shocks.

The ELGO incremental sensors of the LMIX, EMIX, GMIX, KMIX, RMIX product series as well as the battery-powered measuring and display systems of the IZ series can be used to scan the magnetic rings. The magnetic ring encoded with magnetic north/south poles is scanned by the sensor at a defined reading distance.

4.1 Special Features

Due to the use of a steel body, the rings have excellent mechanical tolerances, which allow simple and precise installation. A strip of elastomer-bonded hard ferrite is glued on the surface of the steel ring. After the two components have been glued together, the ring is written with the magnetic information. The writing process is purely angle-controlled which allows a wide variety of possible patterns..

The rings are very resistant and are therefore also suitable for use under demanding environmental conditions as well as for outdoor applications. The manufacturing method also makes it easy to produce application-specific geometries and magnetic patterns.

4.2 Pole Pitches and compatible Sensors

All magnetic ring variants of the MRR / MRA series are available in three different pole pitches. The pole pitch must be selected according to the ELGO measuring system used:

Pole Pitch	Compatible ELGO Measuring Systems
2 mm	EMIX1/2, EMIX23, ESMC1/2 and RMIX2
2.5 mm	IZ14E, IZ15E, IZ16E and IZ17E
5 mm	LMIX1/2, LMIX22, GMIX1A, GMIX2, KMIX2 and LSMC1/2

4.3 Radial Magnetic Rings (MRR)

The radial magnetic rings are designed for mounting on the outside diameter of a shaft or a turned shaft shoulder. They are usually mounted on the shaft by positive locking, e.g. as press fit or thermal fit. Alternatively, the installation can also be performed by gluing with a suitable metal adhesive (e.g. 2-component adhesive).

The magnet sensor scans the magnetic track on the outside of the ring.



Figure 1: Magnetic Rings MRR

4.4 Axial Magnetic Rings (MRA)

The axial magnetic rings are designed for mounting on the face of a shaft. Installation is performed, e.g. via a turned shaft shoulder which is adapted to the inner ring diameter or via a provided recess on the shaft end face. The magnet ring can either be mounted as press or thermal fit, flanged at the front or glued with a suitable metal adhesive (e.g. 2-component adhesive).

The magnet sensor scans the magnetic track on the ring front side.



Figure 2: Magnetic Rings MRA

5 Technical Data and Variants

5.1 General Technical Data

MRR / MRA

Mechanical Data

Magnetic layer material	elastomer bonded hard ferrite
Carrier material	ferromagnetic steel 1.4104 (others on request)
Dimensions	depending on type (see section 5.2.1 and 5.2.2)

Electrical Data

Single pitch error	46 [m°]*
Position error	23 [m°]pp*
Peripheral speed	10 [m/s]*
Max. evaluable edges / revolution	= IF x P (interpolation factor x number of poles)
Maximum rotation speed	6000 [rpm]*

*) based on a reference diameter of 100 mm

Environmental Conditions

Temperature range	-40 ... +85° C
Humidity	max. 95 %, non-condensing
Protection class	IP68

5.2 Type-specific Data

5.2.1 Variant MRR (radial)

Designation*	Ø OD	Ø ID	H	Number of poles (P)	± Pole Pitch
MRR-00-029-020-10-0XXX	29.8 mm	20 mm H7	10 mm	50 / 40 / 20	2 / 2.5 / 5 mm
MRR-00-038-030-10-0XXX	38.7 mm	30 mm H7	10 mm	64 / 52 / 26	2 / 2.5 / 5 mm
MRR-00-048-040-10-0XXX	48.9 mm	40 mm H7	10 mm	80 / 64 / 32	2 / 2.5 / 5 mm
MRR-00-061-050-10-0XXX	61.7 mm	50 mm H7	10 mm	100 / 80 / 40	2 / 2.5 / 5 mm
MRR-00-074-060-10-0XXX	74.4 mm	60 mm H7	10 mm	120 / 96 / 48	2 / 2.5 / 5 mm
MRR-00-079-070-10-0XXX	79.5 mm	70 mm H7	10 mm	128 / 102 / 52	2 / 2.5 / 5 mm
MRR-00-099-080-10-0XXX	99.9 mm	80 mm H7	10 mm	160 / 128 / 64	2 / 2.5 / 5 mm
MRR-00-120-090-10-0XXX	120.2 mm	90 mm H7	10 mm	192 / 156 / 78	2 / 2.5 / 5 mm
MRR-00-131-100-10-0XXX	131.7 mm	100 mm H7	10 mm	210 / 168 / 84	2 / 2.5 / 5 mm
MRR-00-163-140-10-0XXX	163.5 mm	140 mm H7	10 mm	260 / 208 / 104	2 / 2.5 / 5 mm
MRR-00-201-170-10-0XXX	201.7 mm	170 mm H7	10 mm	320 / 256 / 128	2 / 2.5 / 5 mm
MRR-00-329-250-10-0XXX	329.0 mm	250 mm H7	10 mm	520 / 426 / 208	2 / 2.5 / 5 mm
MRR-00-405-275-10-0XXX	405.4 mm	275 mm H7	10 mm	640 / 512 / 256	2 / 2.5 / 5 mm

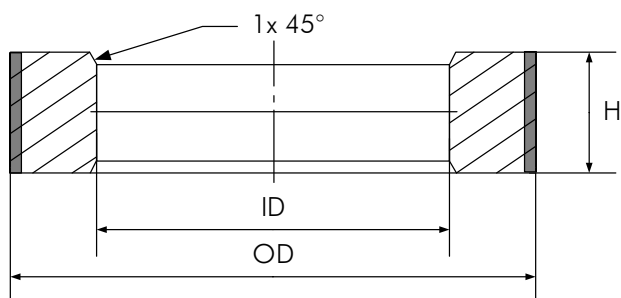

Figure 3: Dimensions MRR

5.2.2 Variant MRA (axial)

Designation	Ø OD	Ø ID	H	Number of poles (P)	± Pole Pitch
MRA-00-045-035-02-0XXX	45 mm	35 mm H7	2 mm	64 / 52 / 26	2 / 2.5 / 5 mm
MRA-00-061-051-02-0XXX	61.3 mm	51,3 mm H7	2 mm	90 / 72 / 36	2 / 2.5 / 5 mm
MRA-00-080-070-02-0XXX	80 mm	70 mm H7	2 mm	122 / 94 / 48	2 / 2.5 / 5 mm
MRA-00-100-090-04-0XXX	100 mm	90 mm H7	4 mm	152 / 120 / 60	2 / 2.5 / 5 mm
MRA-00-130-120-04-0XXX	130 mm	120 mm H7	4 mm	196 / 158 / 78	2 / 2.5 / 5 mm

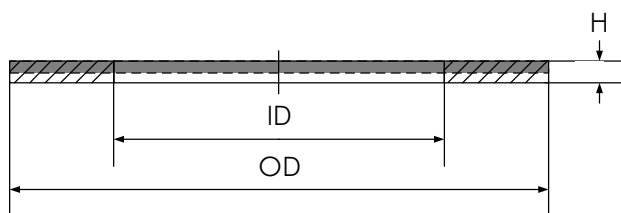

Figure 4: Dimensions MRA

5.3 System Resolution including Sensor

An electrical period (channel A or B) of a square wave signal generally has four evaluable edges. The resolution of an MRR or MRA magnetic ring in combination with the measuring system used is therefore defined for a four-edge evaluation. Furthermore, the resolution of the complete system still depends on the number of magnetic ring poles (related to the circumference and the pole length of the ring) as well as on the interpolation factor of the measuring system used.

The interpolation factor "IF" is calculated as follows:

$$\text{Pole pitch in } \mu\text{m} : \text{Resolution of the measuring system at 4-edge triggering} = \text{IF}$$

Example: 5000 μm (\approx 5 mm pole pitch) : 10 μm (\approx 0.01 mm sensor resolution) = IP 500

5.3.1 Interpolation Factor of ELGO Measuring Systems

The following table shows the interpolation factors (IF) of the ELGO measuring systems at 4-edge triggering:

Measuring System	Standard Resolution	Required Pole Pitch	Interpolation Factor
LMIX, LMIX2, KMIX2	25 μm	5 mm	200
EMIX1, EMIX2	10 μm	2 mm	200
GMIX1A	100 50 25 20 10 μm	5 mm	50 100 200 250 500
GMIX2	2500 μm	5 mm	2
Serie IZ	10 μm	2.5 mm	500
RMIX2	25 μm	2 mm	80

LMIX22	2,5 μm	5 mm	2000
EMIX23	1 μm	2 mm	2000
LMSC1, LMSC2	1 sin/cos period / pole	5 mm	-
EMSC1, EMSC2	1 sin/cos period / pole	2 mm	-

5.3.2 Maximum evaluable Edges per Revolution

The maximum number of evaluable edges per revolution for the complete system is calculated as follows:

IF x P (interpolation factor x number of poles) = maximum number of evaluable edges per revolution

Example: IF 200 x magnet ring with 50 poles = 10,000 evaluable edges

6 Installation

6.1 Mounting on the Axis or Shaft

**NOTE: External Magnetic Fields**

The magnetic ring must not be influenced by external magnetic fields! Magnetic rings must not come into direct contact with other magnetic fields (e.g. permanent magnets, magnetic clamps, electromagnets, magnetic stands)! This may cause irreparable damage, which will compromise the measuring accuracy or even the functioning.

Mounting on the axis or shaft is done differently for radial and axial magnetic rings. While the radial MRR variants are intended for mounting at any position on the outside diameter of an axis or shaft or on a turned shaft shoulder, the axial MRA variants are preferably mounted on the shaft end face.

The connection between ring and shaft can be made either by positive fit (e.g. thermal fit or press fit) or with a suitable metal adhesive (e.g. 2-component adhesive).

**IMPORTANT:**

In general, it is up to the user how he fixes the magnetic ring on the shaft. It is only important that the adaptation to the outer diameter of the shaft is centered and uniform over the entire circumference.

Unbalance must be avoided in any case!

The next pages show non-binding installation examples that illustrate how the magnetic ring can be mounted on the shaft.

6.1.1 MRR - Mounting Examples (radial)

6.1.1.1 Fitting or bonding to a Shaft or Shaft Shoulder

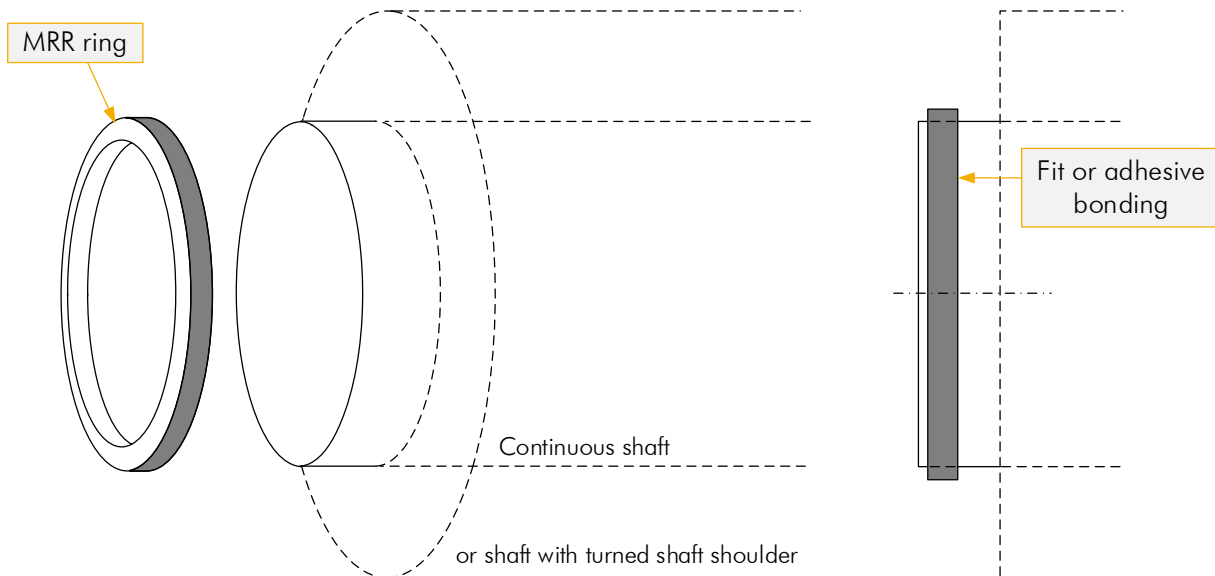
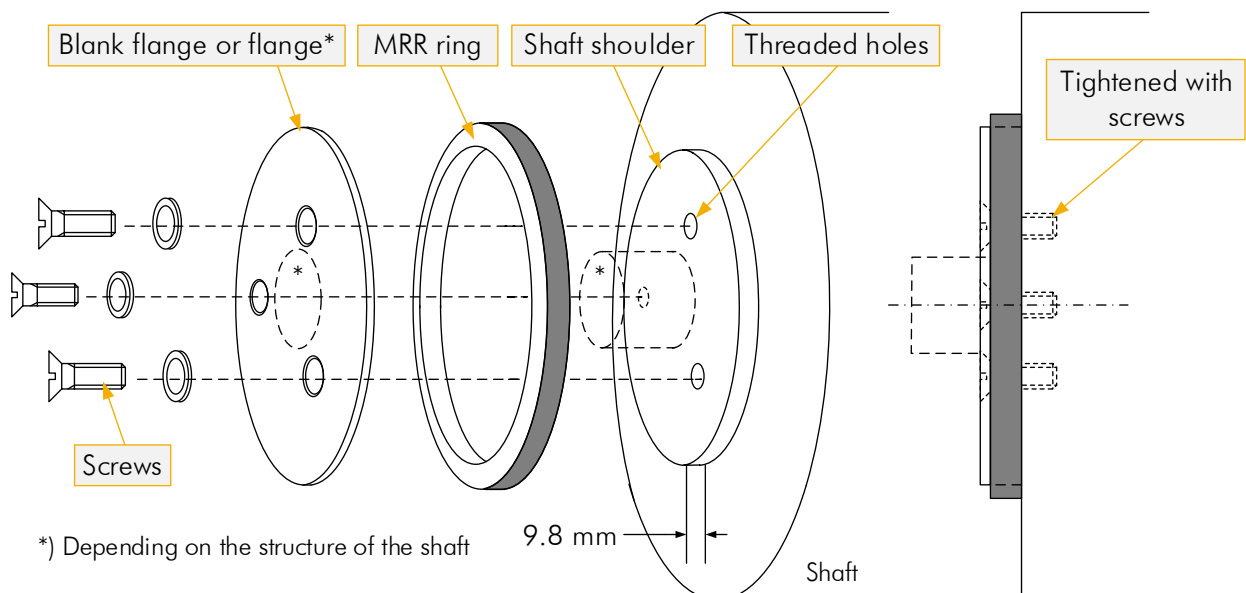

Figure 5: Fitting or bonding to shaft or shaft shoulder

- The adaptation to the outer diameter of the shaft must be uniform over the entire circumference.
- The inner diameter of the magnetic ring is designed for an H7 fit.
- The ring can also be fixed with a suitable metal adhesive (e.g. 2-component adhesive).
- When turning a shaft shoulder, the width of the sensor head used must be taken into account.
The active sensor surface of the measuring system used must be completely covered by the magnetic track.

6.1.1.2 Mounting with a Flange or Blind Flange



*) Depending on the structure of the shaft

Figure 6: Mounting with a flange or blind flange

- The adaptation to the outer diameter of the shaft must be uniform over the entire circumference.
- The shoulder depth must be less than the ring height (e.g. 9.8 mm) so that the ring can be clamped.
- The active sensor surface of the measuring system used must be completely covered by the magnetic track.
- If required, the ring can additionally be glued or fitted to the shaft. The inner diameter of the magnetic ring is designed for an H7 fit.

6.1.2 MRA - Mounting Examples (axial)

6.1.2.1 Fitting or bonding to a Shaft Shoulder

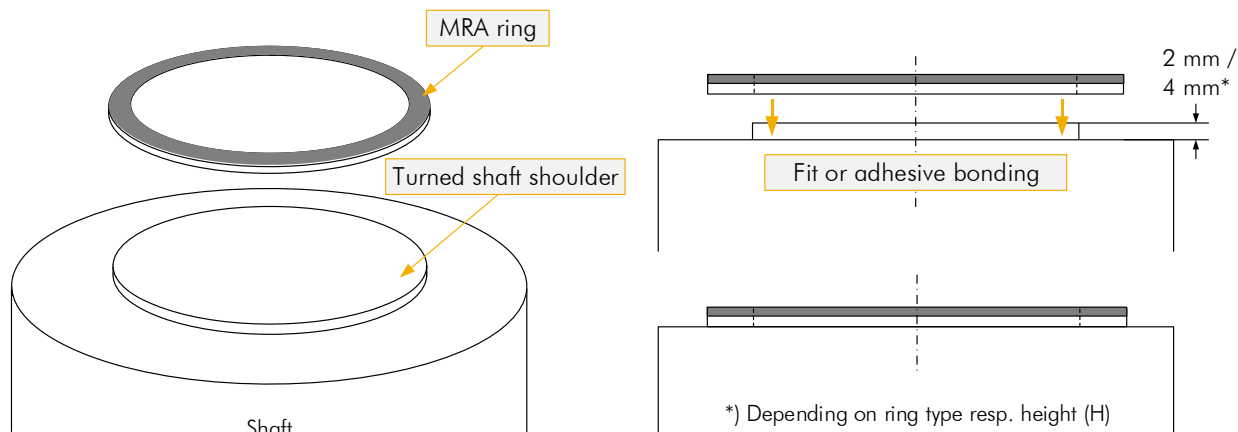

Figure 7: Fitting or bonding to a shaft shoulder

- The adaptation to the outer diameter of the shaft must be uniform over the entire circumference.
- The depth of the shaft shoulder must be at least equal to the height of the magnetic ring. The reading distance prescribed by the measuring system must, however, be able to be maintained. In addition, the sensor head must not touch the shaft shoulder, which means that the shoulder must not protrude too far from the ring. Ideal would be shaft shoulder depth = ring height.
- The active sensor surface of the measuring system used must be completely covered by the magnetic track.
- The inner diameter of the magnetic ring is designed for an H7 fit. If required, the ring can also be fastened with a suitable metal adhesive (e.g. 2-component adhesive).

6.1.2.2 Bonding into a front Profile Recess

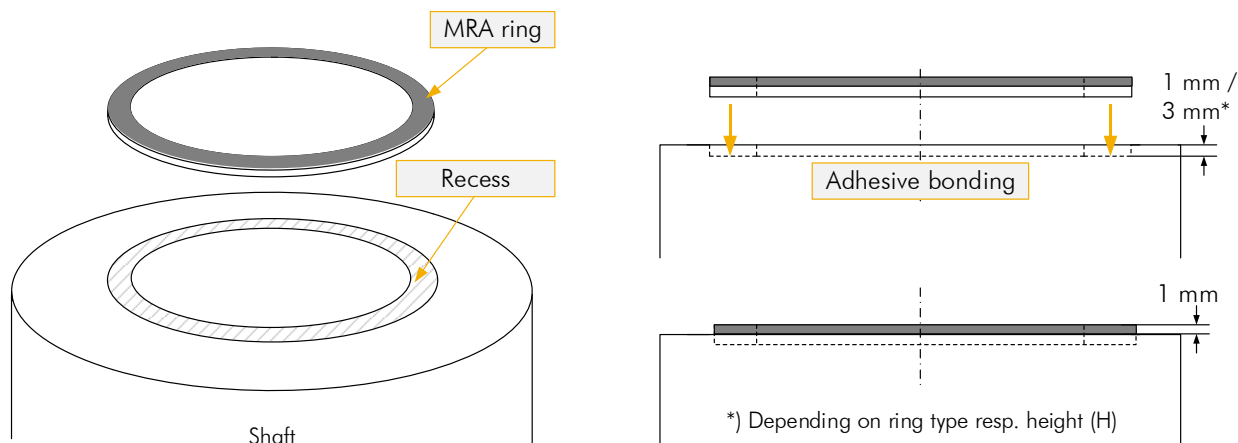

Figure 8: Bonding into a front profile recess

- The recess depth must be selected so that the magnetic layer protrudes 1 mm from the front.
- The recess must not be too wide so that the ring fits properly and no unbalance can occur.
- The active sensor surface of the measuring system used must be completely covered by the magnetic track.
- A suitable metal adhesive (e.g. 2-component adhesive) must be used for bonding.
- If required, the inner side of the ring can also be connected to the shaft via a fit.
The inner diameter of the magnetic ring is designed for an H7 fit.

6.2 Alignment of the different Sensor Types

6.2.1 Alignment of LMIX1, EMIX1, GMIX1A and Series IZ

In the drawing below, the active sensor area is shown as a red hatched area:

MRR (radial)

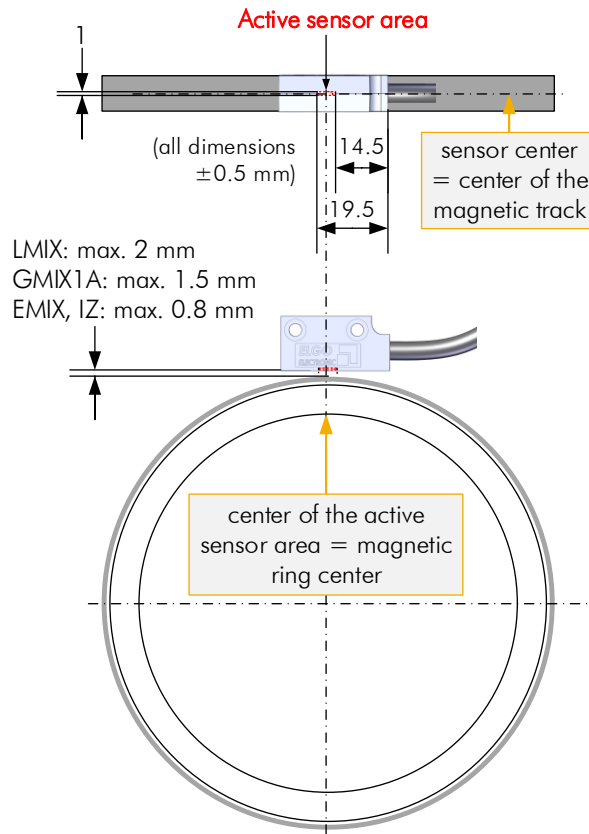

MRA (axial)

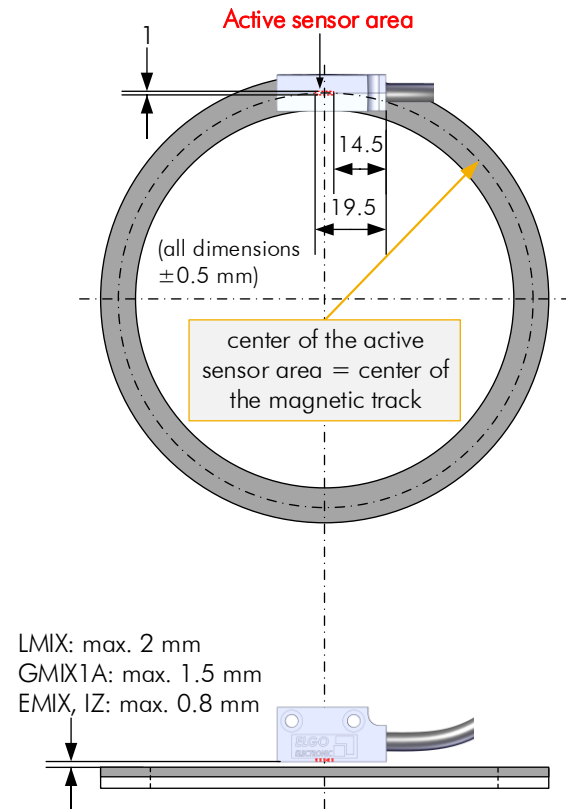

Figure 9: Alignment of LMIX1, EMIX1, GMIX1A and Series IZ

In addition, the respective mounting tolerances must be observed for all measuring systems. These can be found in the corresponding operating manual.

6.2.2 Alignment of LMIX2 / LMIX22 / EMIX2 / EMIX23

6.2.2.1 MRR (radial)

Since the sensor head is 2.5 mm wider than the magnetic ring, it must be ensured that sufficient space is available for mounting on a shaft shoulder (see 6.1.1). It must be possible to align the active sensor surface towards the center of the magnetic track without the sensor head touching the shaft.

In the drawing below, the active sensor area is shown as a red hatched area. Make sure that the entire active sensor surface is within the permitted distance from the magnetic ring. This is achieved by aligning the center of the red marked sensor surface to the center of the magnetic track (top view) as well as to the center of the magnetic ring (side view).

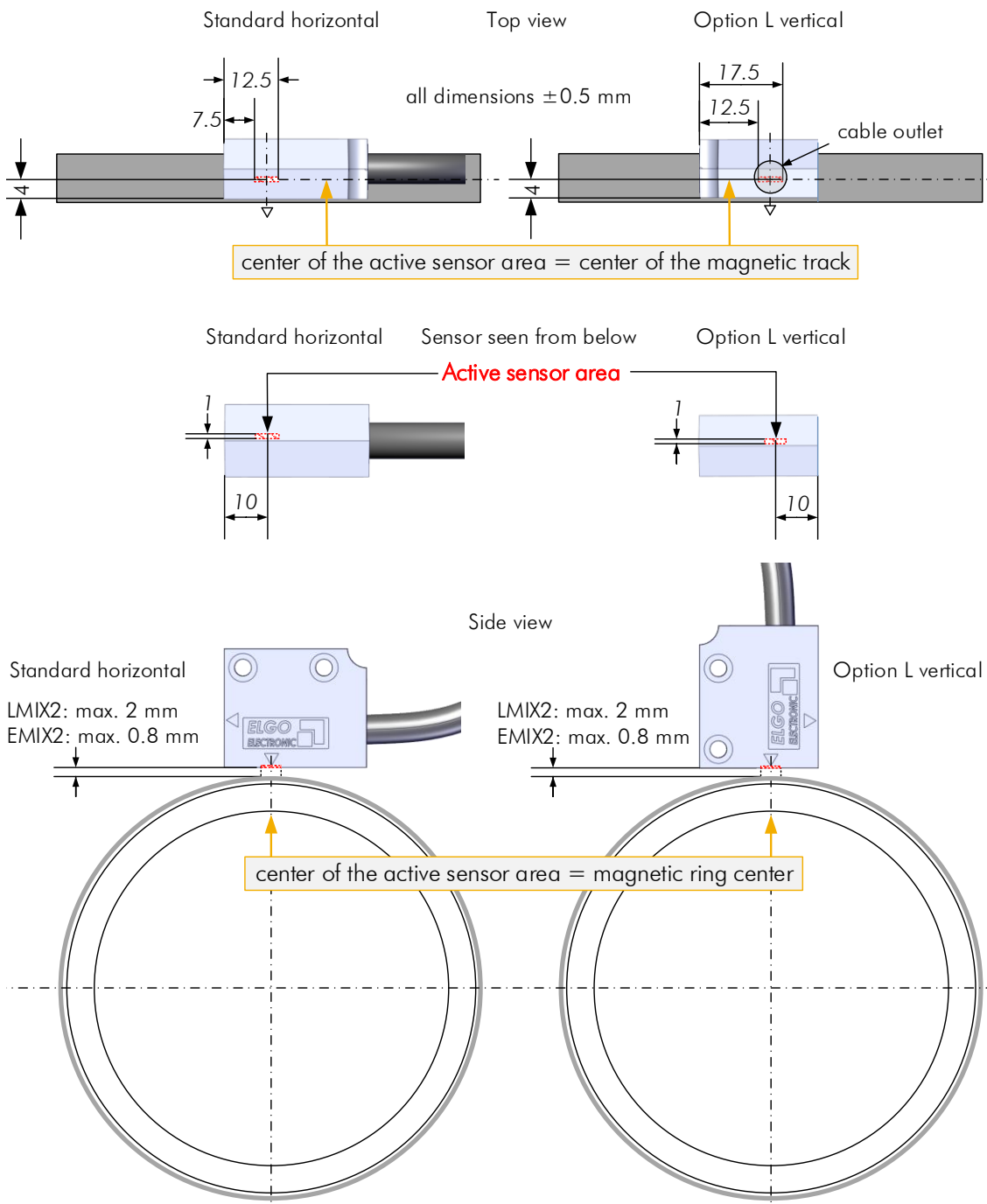

Figure 10: LMIX2 / EMIX2 alignment with MRR

In addition, the respective installation tolerances must be observed (see LMIX2 resp. EMIX2 operating manual).

6.2.2.2 MRA (axial)

When mounting over a front shaft shoulder (see 6.1.2.1), it must be ensured that the turned shaft shoulder is at most deep enough that the sensor does not touch the shoulder and that there is sufficient space to maintain the maximum permitted reading distance.

In the drawing below, the active sensor area is shown as a red hatched area. Ensure that the entire active sensor surface is within the permitted distance to the magnetic ring. This is achieved by aligning the center of the sensor surface to the center of the magnetic track (top view) as well as to the center of the magnetic track (side view).

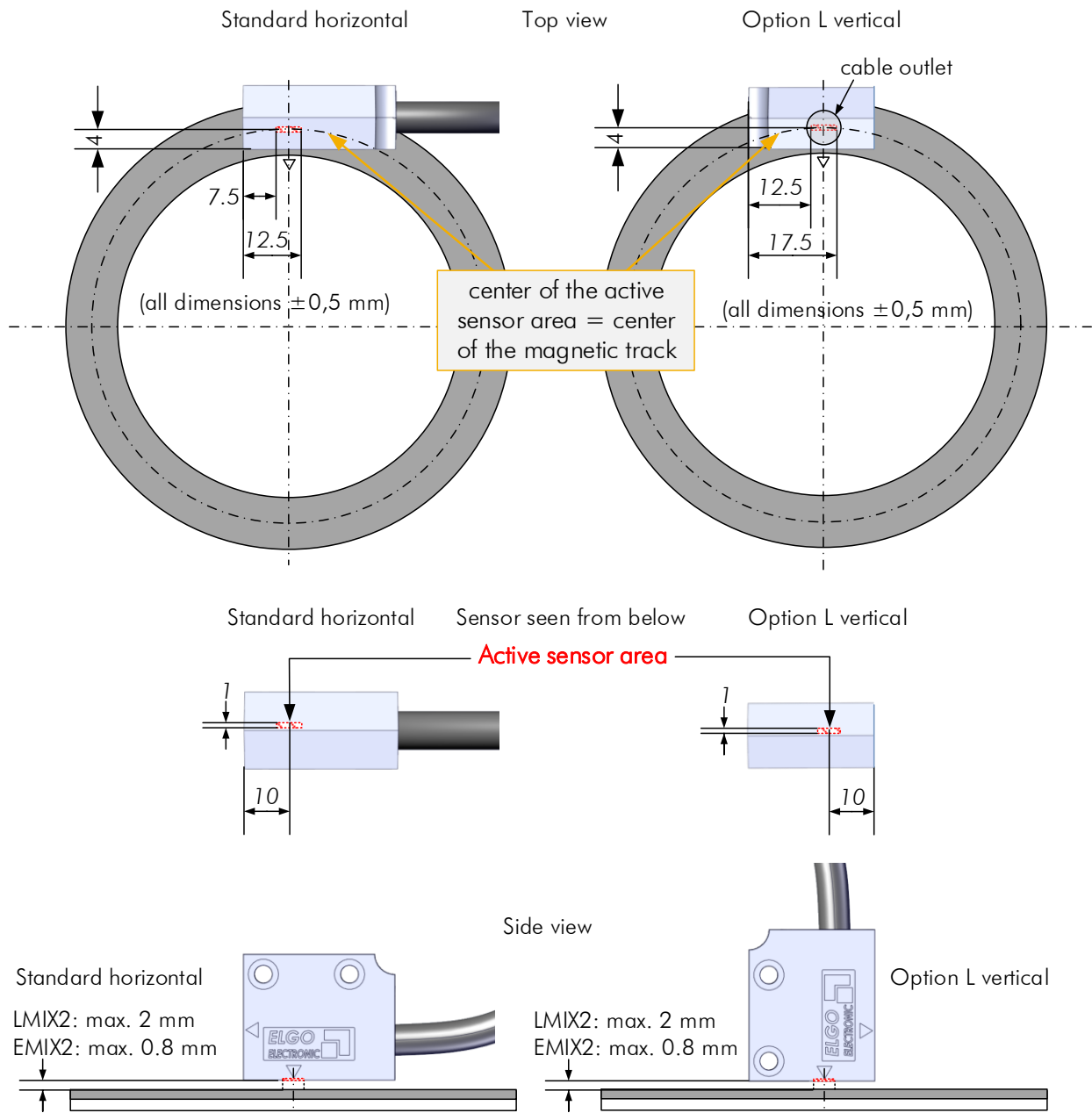

Figure 11: LMIX2 / EMIX2 alignment with MRA

In addition, the respective installation tolerances must be observed (see LMIX2 resp. EMIX2 operating manual).

6.2.3 Alignment of LMIX22 / EMIX23 with Reference Pulse

If a magnetic ring equipped with a reference pulse is used, it can be evaluated with the ELGO measuring systems LMIX22 and EMIX23, provided that option R is also ordered. In this case, the sensor head has two active sensor surfaces (see red hatched surfaces in the following figure):

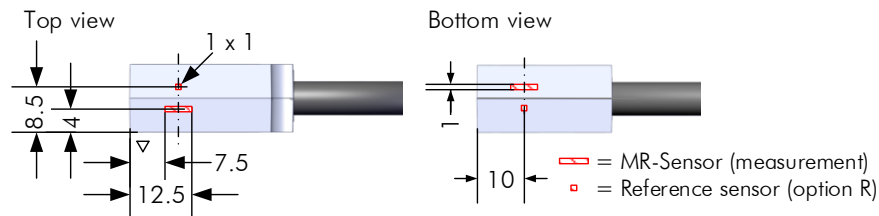
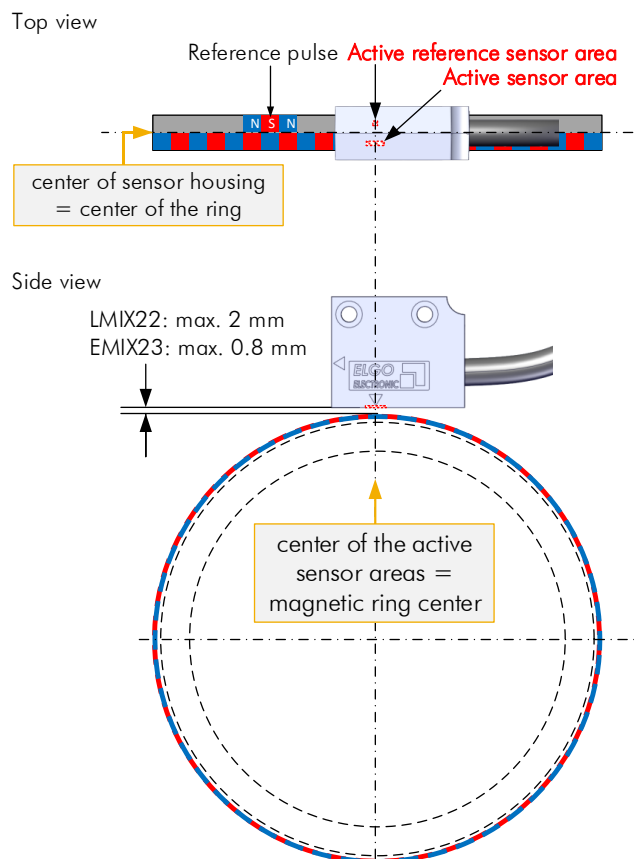

Figure 12: Position of the active sensor areas with LMIX22 / EMIX23

On the magnetic ring, the position of the reference pulse is indicated by a mark. The width of the two magnetic tracks (measuring and reference pulse track) on a standard magnetic ring is 5 mm each.

MRR (radial)



MRA (axial)

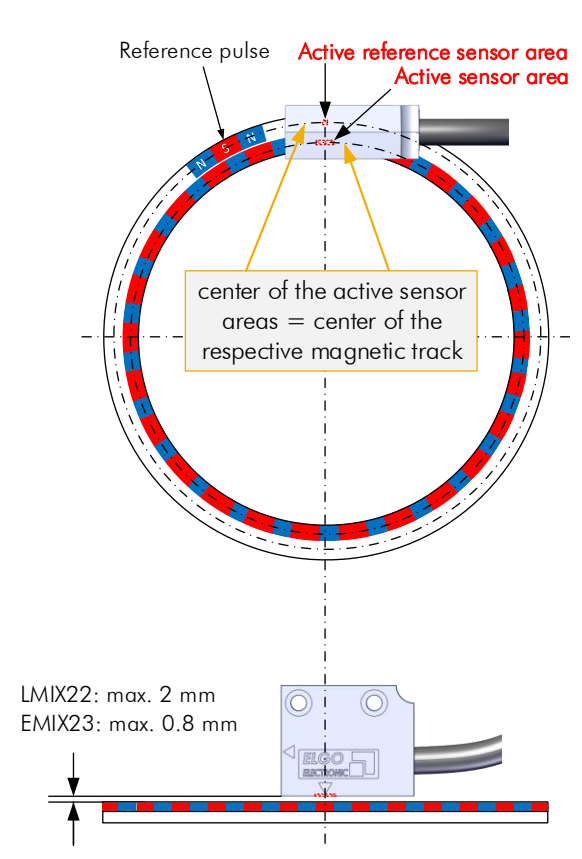



Figure 13: Alignment of LMIX22 / EMIX23 (option R)

	<p>REMARKS:</p> <p>Option R is available for horizontal LIMIX22 / EMIX23 variants only (not possible with option L).</p> <p>The coding pattern of the magnetic ring shown in the drawing above is an example of the standard version with separate reference pulse track. Other resp. customer-specific samples are available on request.</p>
---	--

6.2.4 Alignment of GMIX2

Make sure that both active sensor areas are covered within the permissible 4 mm distance. With the radial MRR variant, the diameter of the ring must be selected accordingly large.

MRR (radial)

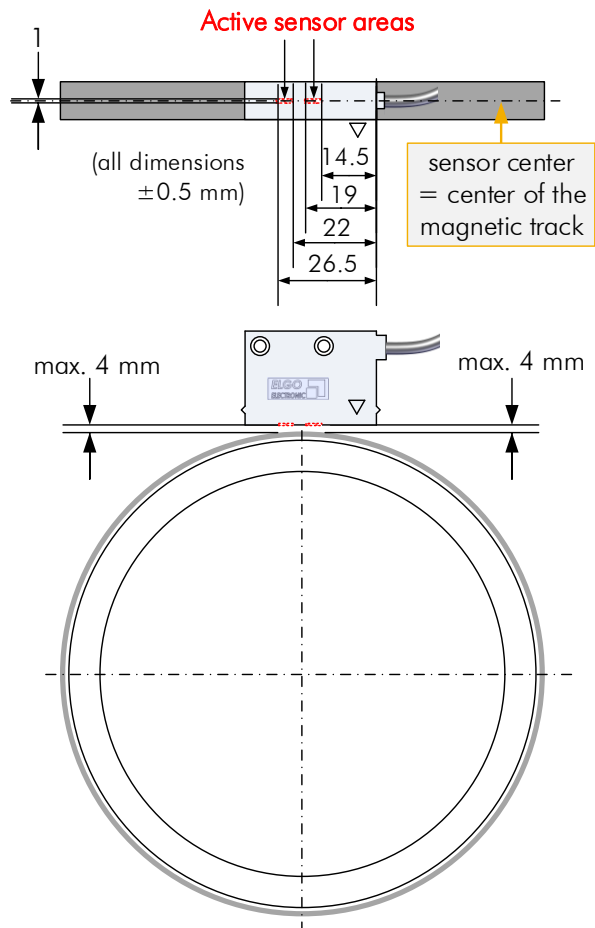

MRA (axial)

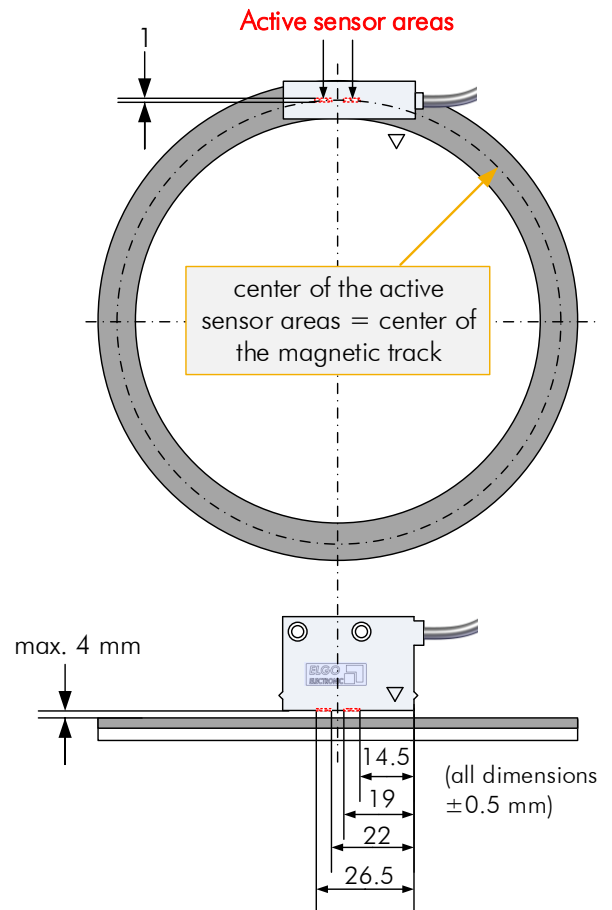

Figure 14: Alignment of GMIX2

In addition, the respective installation tolerances must be observed (refer to the GMIX2 operating manual).

6.2.5 Alignment of RMIX2

Ensure that the entire active sensor area is within the permitted distance to the magnetic ring. In the following drawing the active sensor area is shown as a red hatched area.

MRR (radial)

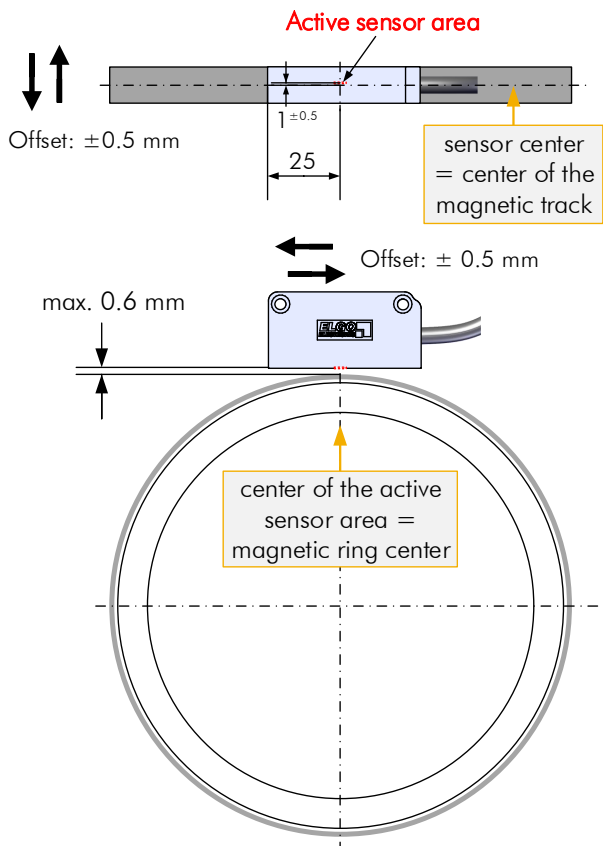

MRA (axial)

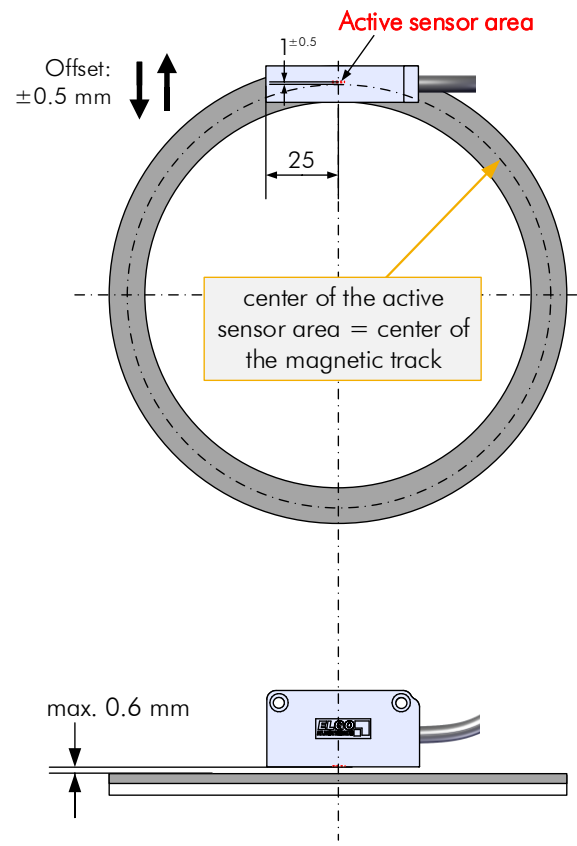

Figure 15: Alignment of RMIX2

In addition, the respective installation tolerances must be observed (refer to the RMIX2 operating manual).

6.2.6 Alignment of KMIX2

The KMIX2 sensor has a notch which serves for orientation during mounting. The notch must be aligned as shown in Figure 16 below.

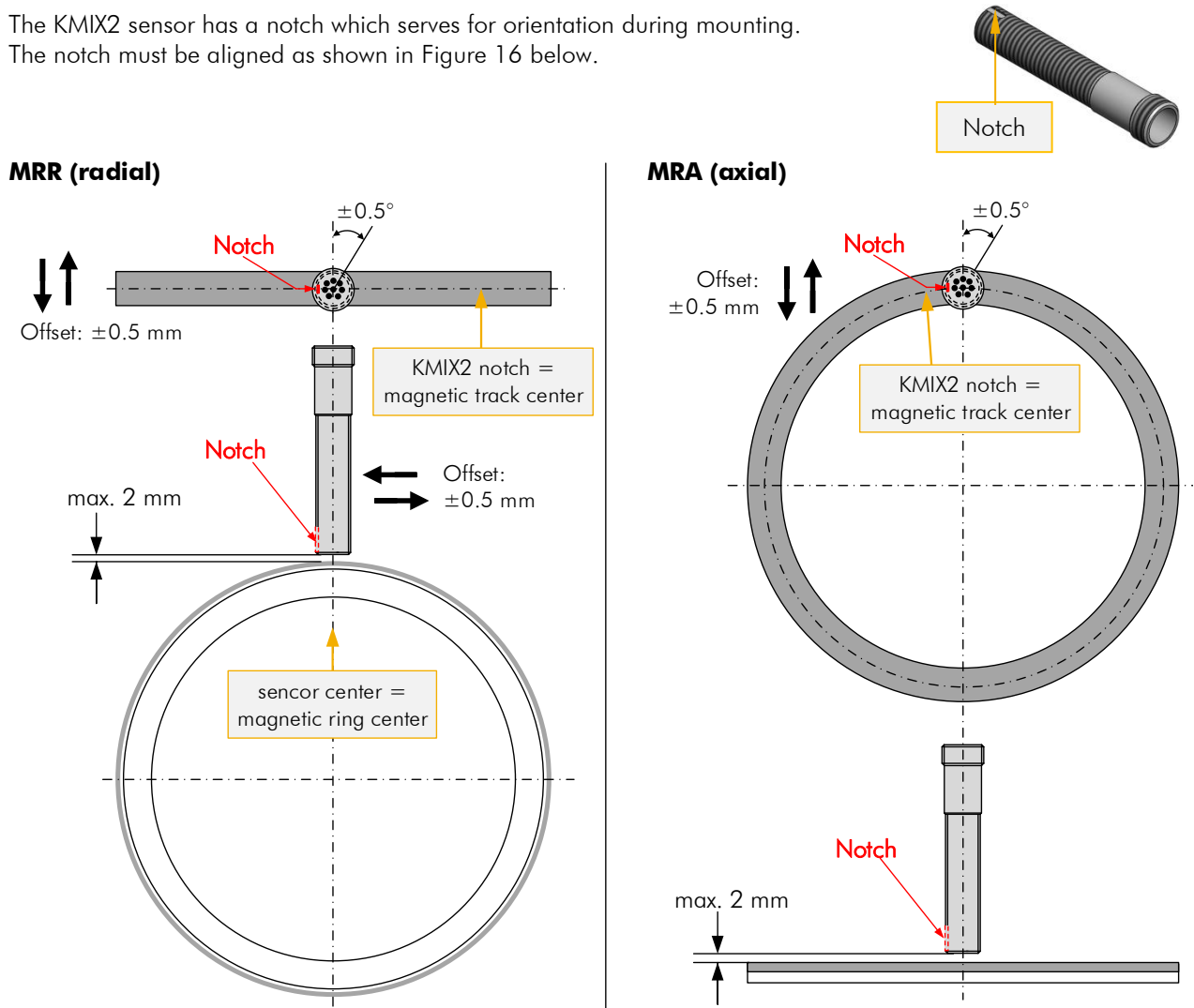

Figure 16: Alignment of KMIX2

In addition, the respective installation tolerances must be observed (refer to the KMIX2 operating manual).

7 Maintenance and Cleaning

7.1 Maintenance

The product operates maintenance-free.

7.2 Cleaning



WARNING!

The device can only be cleaned with a damp cloth, do not use aggressive cleanser!

8 Type Designation

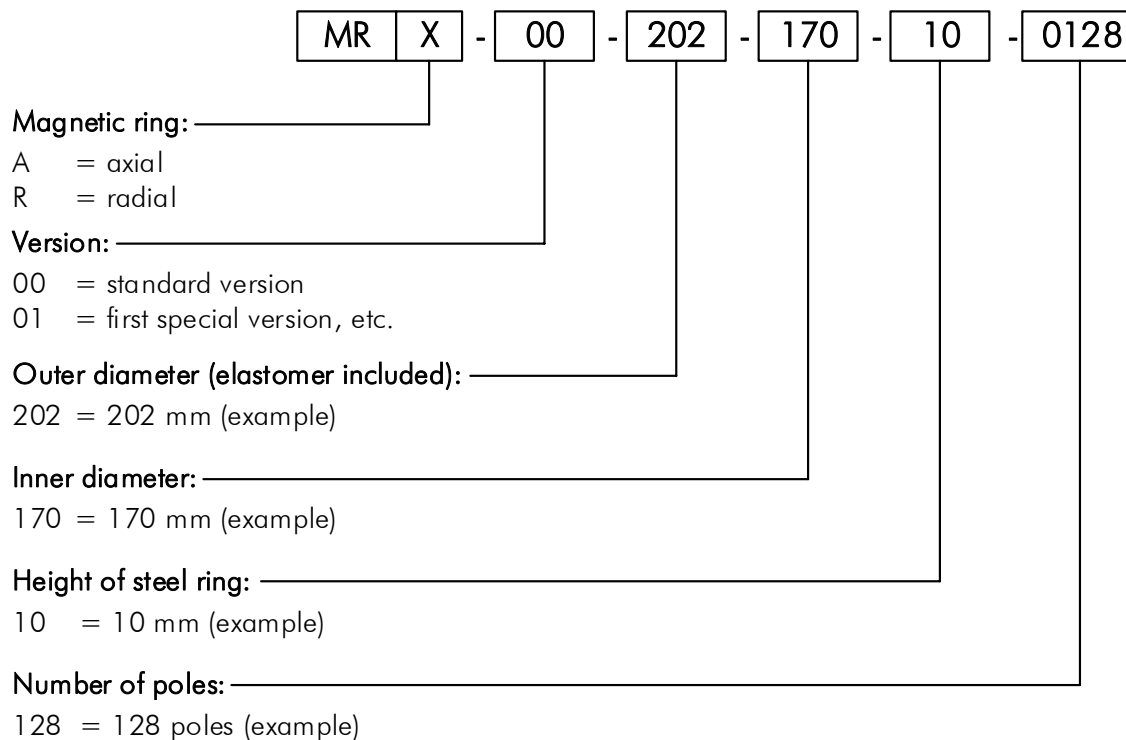

The type designation shown above shows the order code by means of examples. The exact type designations can be found in the tables of sections 5.2.1 Variant MRR (radial) and 5.2.2 Variant MRA (axial).



IMPORTANT:

Please note that different pole pitches must be selected depending on the selected measuring system. Please read section 4.2 for more information. An incorrect pole pitch leads to incorrect measurement values!

The pole pitch of the magnetic ring results automatically from the definition of the number of poles. These can be found in Table 5.2.1 and 5.2.2.

8.1 Accessories

Order Designation	Description
POSU	Pol finder card 85 x 55 mm (makes the magnetic ring poles visible)

9 Index

Accessories	22	Mounting on the Axis or Shaft.....	12
Accident prevention regulations.....	5	MRA - Mounting Examples (axial)	14
Alignment of GMIX2	19	MRR - Mounting Examples (radial)	13
Alignment of KMIX2	21	Operational safety.....	5
Alignment of LMIX1, EMIX1, GMIX1A and Series IZ	15	Packaging material.....	7
Alignment of LMIX2 / LMIX22 / EMIX2 / EMIX23	16	Pole Pitches and compatible Sensors	8
Alignment of LMIX22 / EMIX23 with Reference Pulse	18	Product Features	8
Alignment of RMIX2	20	Protective equipment	6
Alignment of the different Sensor Types.....	15	Radial Magnetic Rings (MRR)	8
Axial Magnetic Rings (MRA)	8	Safety	5, 6
Causes of risk.....	6	Safety instructions	5
Cleaning.....	21	Safety rules	5
Conventional use.....	7	Special Features.....	8
Demounting	6	Storage	7
Disposal.....	6	System Resolution including Sensor	10
Explanation of symbols.....	5	Technical Data and Variants.....	9
General Technical Data	9	Transport	7
Installation	12	Transport damage	7
Interpolation Factor of ELGO Measuring Systems	10	Type Designation	22
Maintenance	21	Type-specific Data	9
Maximum evaluable Edges per Revolution	11	Variant MRA (axial)	10
		Variant MRR (radial)	9

Document- No.: 799000912 / Rev. 2
Document- Name: MRR-MRA-00-MA-E_05-22
Subject to change - © 2022
ELGO Electronic GmbH & Co. KG

ELGO Electronic GmbH & Co. KG
Measuring | Positioning | Control
Carl - Benz - Str. 1, D-78239 Rielasingen
Fon: +49 (0) 7731 9339-0, Fax: +49 (0) 7731 28803
Internet: www.elgo.de, Mail: info@elgo.de

