

Operation manual

SERIES IZ16E-000

Battery-powered Length Measuring System



- Large 7-digit LCD-Display, digit height 14 mm
- With sign and special signs
- Battery status indicator
- „°“-symbol for angle measurement
- Fraction display in inch mode
- Internal or external battery case
- Resolution up to 0.01 mm
- Display in inch mode „0.001 Inch“
- Tool-offset
- Simple installation (Snap-In-Housing)
- Option built-on enclosure with mounting holder

Content

1	General	4
1.1	Information Operation Manual	4
1.2	Explanation of Symbols	4
1.3	Statement of Warranties	5
1.4	Demounting and Disposal	5
2	Safety	6
2.1	General Cause of Risks	6
2.2	Personal Protective Equipment	6
2.3	Conventional Use	7
3	Transport and Storage	8
3.1	Safety instructions for transport, unpacking and loading	8
3.2	Handling of Packaging Material	8
3.3	Check of Transport	8
3.4	Storage	8
4	Product Features	9
5	Applications	10
5.1	Magnetic measurement	10
5.1.1	Direct Distance Measurement	10
5.1.2	Angle Measurement 0...<360°	10
5.2	Measurement with pole ring	11
5.2.1	Indirect Distance Measurement	11
5.2.2	Angle Measurement 0...360°	11
6	Technical Data	12
6.1	Position Indicator IZ16E	12
6.1.1	Identification	12
6.1.2	Dimensions	12
6.1.2.1	Front View / valid for all versions	12
6.1.2.2	Version IZ16E-000-1-xx,x-0	13
6.1.2.3	Version IZ16E-000-6-xx,x-0	13
6.1.2.4	Version IZ16E-000-1-xx,x-1	14
6.1.2.5	Version IZ16E-000-6-xx,x-1	14
6.1.2.6	Version IZ16E-000-8-xx,x-1-AG	15
6.1.3	Technical Data IZ16E	16
6.1.4	Power supply / Battery change	17
6.2	Magnetic Sensor MS 20.25	18
6.2.1	Dimensions of the Magnetic Sensor	18
6.2.2	Technical Data of the Magnetic Sensor	18
6.3	Magnetic Tape MB20-25	19
6.3.1	Components	19
6.3.2	Handling	20
6.3.3	Identification	20
6.3.4	Dimensions of the Magnetic Tape	20
6.3.5	Technical Data Magnetic Tape	21
6.3.6	Chemical resistance of the magnetic tape	21
7	Type Designation	22
7.1	Available Variants	23
8	Type Designation Magnetic Tape	24
8.1	Available Variants	24
9	Installation and Initial Start-up	25
9.1	Operational Environment	25
9.2	Interferences	26
9.3	Mounting description / Installation of the Indicator	27

9.3.1	Installation IZ16E-000-x-xx.x-x in the front panel	27
9.3.2	Installation IZ16E-000-x-xx.x-x with a mounting angle.....	28
9.3.3	Installation IZ16E-000-8-xx.x-1-AG.....	29
9.4	Activating the device.....	30
9.5	Description of mounting / Installation of the magnetic sensor	30
9.6	Installation of the magnetic tape.....	31
9.6.1	Processing note for the bonding.....	31
9.6.2	Cutting and Sticking	32
10	Structure and Function	33
10.1	Overview-Display.....	33
10.2	Key-Overview.....	34
10.3	Parameter Level	35
10.3.1	Activate the Parameter Level	35
10.3.2	Election of the Decade	35
10.3.3	Change Value	35
10.3.4	Change Sign.....	35
10.3.5	Leave Parameter Level	35
10.3.6	Parameter list	36
10.4	Initialization Level.....	37
10.4.1	Calibration	37
10.4.2	Load the Default Parameters and simultaneous Calibration.....	37
10.5	Function at the Operator Level.....	38
10.5.1	Actual Value to Reference	38
10.5.2	Direct entry to value to reference.....	38
10.5.3	Switching incremental or absolute	38
10.5.4	Activation Offset Measurements	38
10.5.5	Fraction Display in the Inch-Mode.....	39
11	Accessories.....	40
11.1	Mounting angle	40
11.2	Battery Holder	41
11.3	Cover Band individual	42
11.4	Aluminum Guiding Rail.....	42
11.5	Guiding Wagon for Guiding Rail.....	42
11.6	Magnetic Tape End Cap	43
12	Interferences	44
12.1	Safety.....	44
12.2	Restarting after fault clearance	44
13	Maintenance	45
14	Cleaning	45
15	Index	46
16	Document History.....	47

1 General

1.1 Information Operation Manual

The manual contains important information regarding the handling of the indicator.
For Your own safety please note all safety warnings and instructions.

Precondition for safe operation is the compliance with the specified safety and handling instructions. Moreover, observe the existing local accident prevention regulation and general safety rules.



Please read the operation manual carefully before starting to work. The manual should be kept accessible at anytime. The illustrations in the manual are for better representation of the facts they are not necessarily to scale and can be slightly different to the actual construction.

1.2 Explanation of Symbols

Warning notices are characterised by symbols in the operation manual.
The notes will be introduced by signal words to express the magnitude of the danger.

Follow these advices in order to avoid accidents and injuries to persons and property.

Warning notices:

	<p>DANGER!</p> <p>This symbol in connection with the signal word „Danger“ indicates an immediate danger for the life and health of persons. Failure to heed these instructions can result in serious damage to health and even fatal injury.</p>
	<p>WARNING!</p> <p>This symbol in connection with the signal word „Warning“ indicates a possible danger to the life and health of persons. Failure to heed these instructions can result in serious damage to health and even fatal injury.</p>
	<p>ATTENTION!</p> <p>This symbol in connection with the signal word „Caution“ indicates a possibly dangerous situation. Failure to heed these instructions can lead to minor injury or property damage.</p>

Specific safety instructions:

**DANGER!**

...marks perilous situations by electricity. By non-observance of the safety instructions the possibilities of death or severe injuries exist. The operations have to be carried out only by an electrician.

Tips and recommendations:**Note!**

Here you can see Highlights, useful tips, information and recommendations for efficient and trouble-free operation.

1.3 Statement of Warranties

The warranty conditions are in a separate document.

Guarantee

The producer guarantees the functional capability of the process engineering and the selected parameter. The period of warranty is one year and begins with the date of delivery.

1.4 Demounting and Disposal

Unless otherwise authorized, dispose the item considering the safety instructions.

Before demounting

- Disconnect the power supply
- Secure against re-start
- Disconnect supply lines physically and discharge remaining energy
- Dispose operating supplies with respect to the environment

Disposal

Recycle the decomposed elements:

- Scrap metal elements
- Electronic components in electronic scrap
- Recycle plastic parts
- Dispose the rest of the components according to their material consistence

**ATTENTION!**

Wrong disposal → damage caused to the environment!

Electronic waste, electronic components, lubricants and operating supplies are liable to treatment of hazardous waste. Only approved specialized companies should perform disposal.



Local authorities and waste management facilities provide information about environmentally suitable disposal.

2 Safety

	<p>ADVERT Please read the operation manual carefully, before using the device! Observe the Installation instructions! In case of damage caused by failure of these operating instructions the warranty expires.</p> <p>ELGO Electronic GmbH & Co. KG and its subsidiaries are not liable for any damage to persons, property or asset caused by defective material on the device and / or its associated. We take no responsibility for consequential damage!</p> <p>The operator is obliged to appropriate security-related measures and implement.</p> <p>The Commissioning may only be performed by qualified and by the operator authorized and trained personnel.</p>
---	---

2.1 General Cause of Risks

This chapter gives an overview about all important safety aspects to guarantee an optimal protection of employees. (See at chapter 9)

Non-observance of the instructions mentioned in this operation manual can result in hazardous situations.



2.2 Personal Protective Equipment

Employees should wear protective clothing during installation of the device to minimize the risk of accidents.

Therefore:

Change into protective clothing before beginning the work process. Also observe any labels in the operating area regarding protective clothing.

Protective clothing:

	<p>Safety working clothing ... is close-fitting ... is tear proof ... has tight sleeves without distant parts</p> <p>Also wear no rings, necklaces or other jewellery.</p>
	<p>Protective gloves ... for protecting the hands against abrasion and cuts.</p>

2.3 Conventional Use

The indicator **IZ16** is for the limited purpose as described in this manual:

The IZ16E ELGO length measurement system is constructed for measuring and displaying distances.



CAUTION!

Danger through non-conventional use!
Non-intended use and non-observance of this operation manual can lead to dangerous situations.

Therefore:

- Use **IZ16E** only as described
- Strictly follow this manual

Avoid in particular:

Remodelling, refitting or changing of the device or parts of it with the intention to alter functionality or scope of the position indicator.

ELGO is not liable for any damages resulting from improper use of the product.
The Operator is liable for all damages during non-conventional use.

3 Transport and Storage

3.1 Safety instructions for transport, unpacking and loading

**ATTENTION!**

Professional transport only.
Do not throw, hit or fold the package.

3.2 Handling of Packaging Material

Adverts for proper disposal refer to 1.4.

3.3 Check of Transport

Examine delivery immediately after receiving for completeness and transport damages.

In case of externally recognizable transport damages:

- Do not accept the delivery or do accept under reserve
- Note extent of damages on the transportation documents or on the delivery note
- File complaint immediately

**ADVERT!**

Claim any damages you recognize as soon as possible. The claims for damage must be filed in the lawful reclaim periods.

3.4 Storage

Store device only under following conditions:

- Do not store outside
- Keep dry and dust-free
- Do not expose to aggressive media
- Protect from direct sun light
- Avoid mechanical shocks
- Storage temperature: 10 to + 60 °C
- Relative humidity: 80 % non-condensing
- Inspect packages regularly if stored for an extensive period of time (> 3 months)

4 Product Features

The length measuring system **IZ16E** is a combination of an external magnetic sensor that is connected via a drag-chain suitable cable to the display device.

For the measurement a coded magnetic tape, which provides the sensor with the necessary information (current position), is glued along the distance that has to be measured. Therefore, the sensor is installed parallel without contact to the magnetic tape and because of that the system is wearless.

The external sensor with its protection class is resistant for any type of dust, dirt and water-jet and with its compact installation size it is easy to integrate in existing or new constructions.

The position indicator has extensive possibilities of parameterization (see section 10.3.6) and can be easily adapted to different applications. The basic functions, which are available in the standard-software, cover a wide range of applications. There are also customized versions (on request) available for special types of machines.

For the installation no special tools are needed, there are no wire or electrical connections required. The length measuring system **IZ16E** is therefore particularly suitable for e.g. mounting on movable slides and stop systems, since no power supply cables are to be accompanied. The new snap-in mounting (snap-in-housing) allows an easy installation in a defined panel cut out e.g. in a front panel.

The option built-on enclosure with mounting holder allows flexible assembling (mounting holder above / mounting holder below / angle adjustable). Retrofitting is also simplified.

**ADVERT**

In the power-off mode the movements or adjustments of the magnetic sensor are not covered!
A reference has to be conducted after the start of operation (at a required mechanical position, the indicator is to set e.g. ZERO)

**ADVERT**

The resolution of the measurement system is 0.01 mm!
All settings of the multiplication factor refer to this resolution!

5 Applications

5.1 Magnetic measurement

5.1.1 Direct Distance Measurement

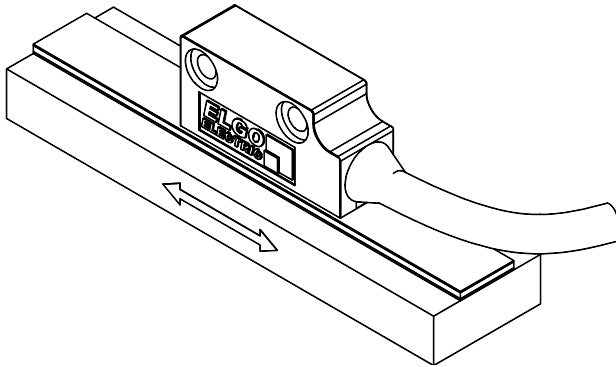

The magnetic tape is glued on a solid ground (e.g. machine base) along the measuring distance.

Example 1) Indicator [mm], resolution 0.01mm
→ P02=0 / P03=2 / P08=1,0000

Example 2) Indicator [m], resolution 0.001m
→ P02=2 / P03=3 / P08=0,01

Example 3) Indicator [Inch], resolution 0.001 Inch
→ P02=1 / P03=fixiert=3 / P08=1,0000

5.1.2 Angle Measurement 0...<360°

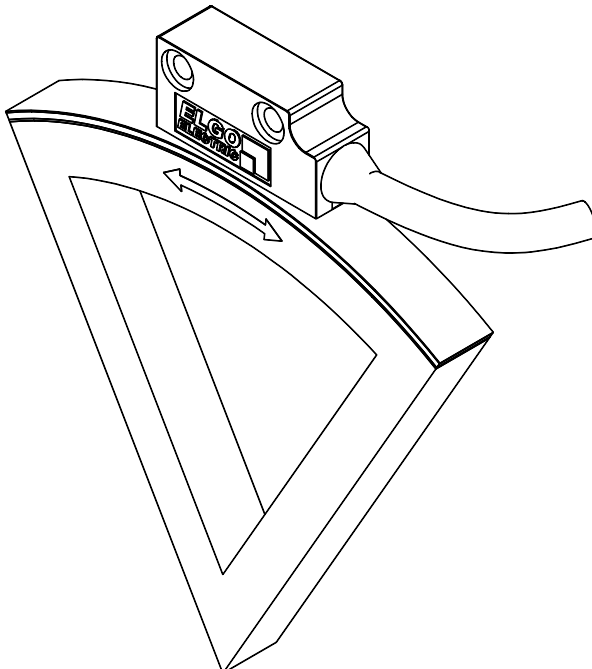

The magnetic tape is glued on a solid ground (e.g. angle stop) along the measuring distance.

To parameterize the indicator or to calculate the multiplication factor a low angle of 90° is very suggestive, the reason is that the actual measurement distance (=angle) is dependent on the bending radius of the magnetic tape.

Example: Indicator [°], resolution 0.01°
→ P02=3 / P03=2 / P08=1,0000 / P09=0

- a) Start to the desired mechanical Zero point, then set the indicator to the reference value.
- b) Start to the defined angle position (e.g. low angle, 90°) and note the actual value at the indicator (e.g. 471,20)
- c) Calculate and enter the multiplication factor:

$$P08 = \text{Angle} / \text{Display Value}$$

(e.g. $P08 = 90^\circ / 471,20 = 0,1910$)

→ P02=3 / P03=2 / P08=0,1910

5.2 Measurement with pole ring

5.2.1 Indirect Distance Measurement

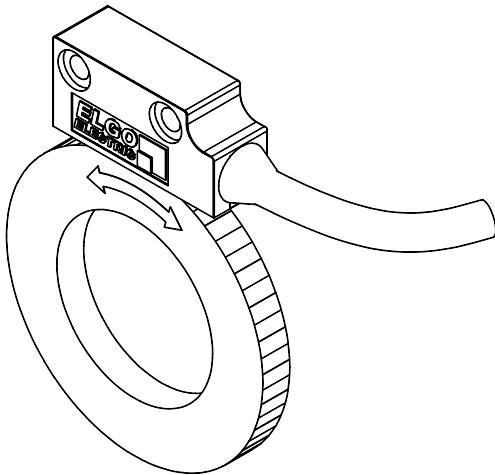

A pole ring / magnet wheel is mounted on a rotating axis (e.g. motor shaft).

Example: Spindle drive with gear box, the pole ring at the engine, indicator [mm], resolution 0.01 mm, pole ring (D=48mm) with 60 poles per ≈ 2.5 mm, transmission reduction = 10:1, Distance per spindle revolution = 3mm

→ P02=0 / P03=2 / P08=

Displayed Value / $R_{\text{magnet wheel}}$ = Number of poles * 250

(e.g.: $60 * 250 = 150.00$ mm)

Measuring Distance / $R_{\text{magnet wheel}}$ = 3 mm / 10 = 0.3 mm

→ P08 = Measuring Distance / $R_{\text{magnet wheel}}$ / Displayed Value / $R_{\text{magnet wheel}}$ = 0.002

→ P02=0 / P03=2 / P08=0,002

5.2.2 Angle Measurement 0...360°

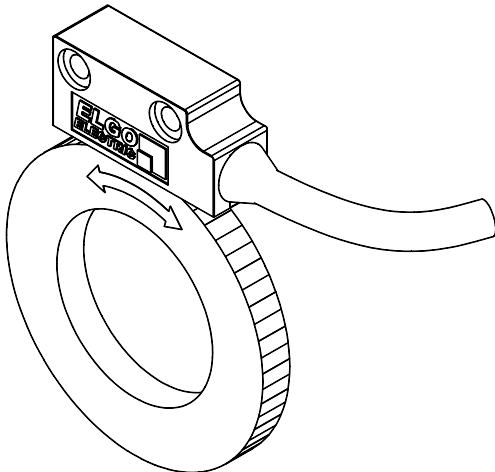

A pole ring / magnet wheel is mounted on a rotating axis.

Example: Angle measurement, Indicator [°], resolution 0.1°, pole ring (D=48mm) with 60 Poles per ≈ 2.5 mm

→ P02=3 / P03=1 / P08=

P08 = (360° / resolution) / (Number of poles * 250)

(e.g.: $(360^\circ / 0,1^\circ) / (60 * 250) = 3600 / 15000 = 0,24$)

→ P02=3 / P03=1 / P08=0,2400

6 Technical Data

6.1 Position Indicator IZ16E

6.1.1 Identification

The label is helpful for the identification of the unit. It is located on the housing of the position indicator. It provides information about the exact type designation (= order reference; see model code, section 7) with the corresponding item number.

Furthermore, the label contains a unique, traceable device number and production date. These data are always necessary information if you contact ELGO.

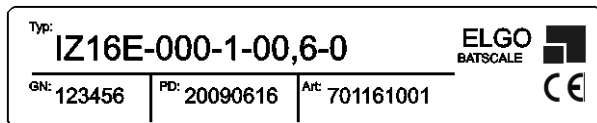

6.1.2 Dimensions

6.1.2.1 Front View / valid for all versions

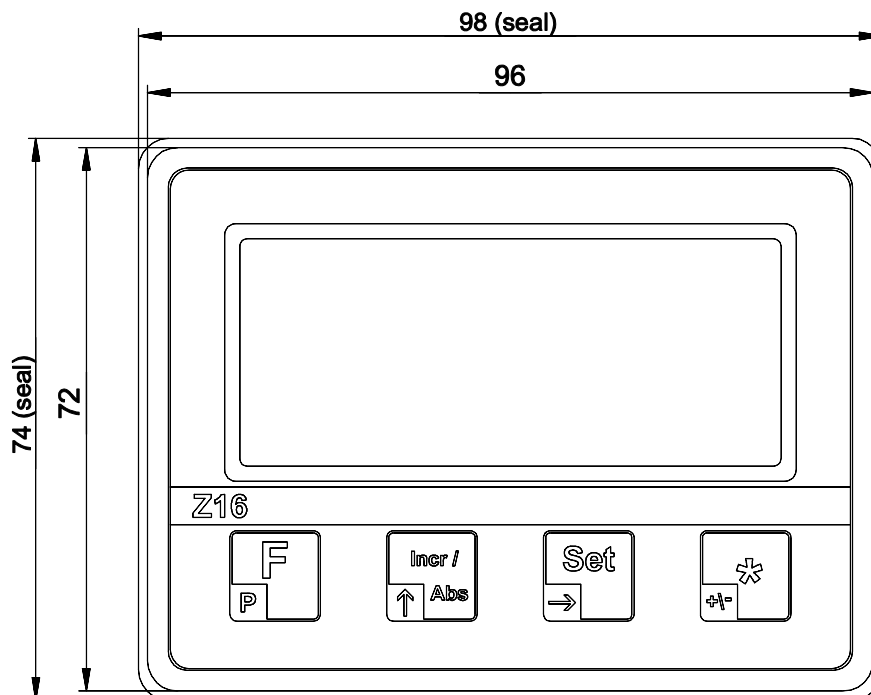

Front panel cut out:	(W x H) = 93mm x 67mm
Appropriate front panel thickness:	1.0 / 1.5 / 2.0 / 2.5 mm (with mounted seal) 2.5 / 3.0 / 3.5 mm (without seal)

6.1.2.2 Version IZ16E-000-1-xx,x-0

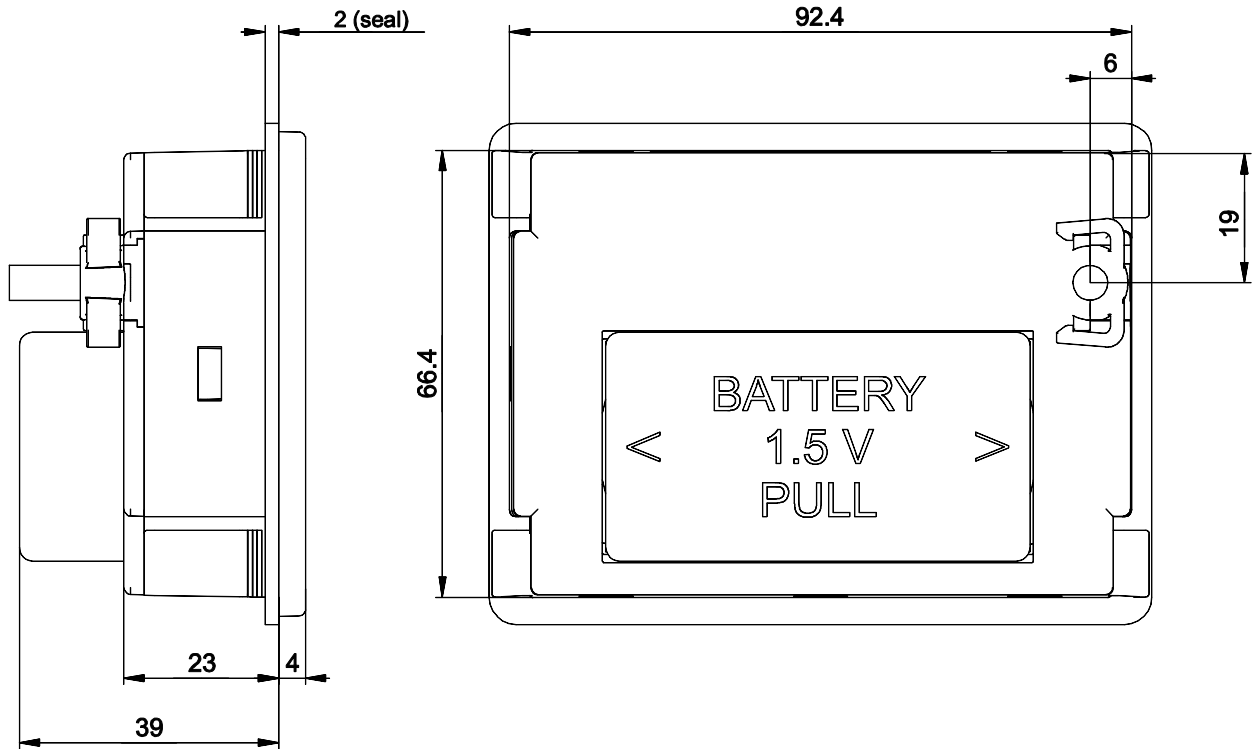

6.1.2.3 Version IZ16E-000-6-xx,x-0

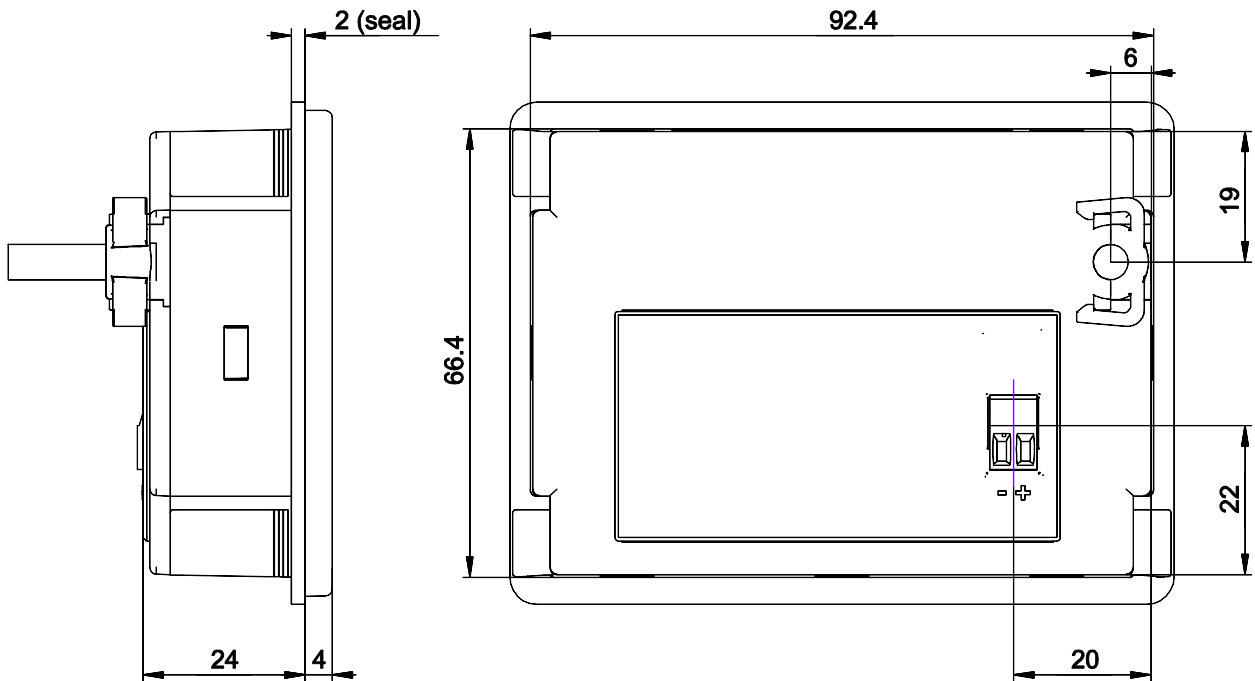

6.1.2.4 Version IZ16E-000-1-xx,x-1

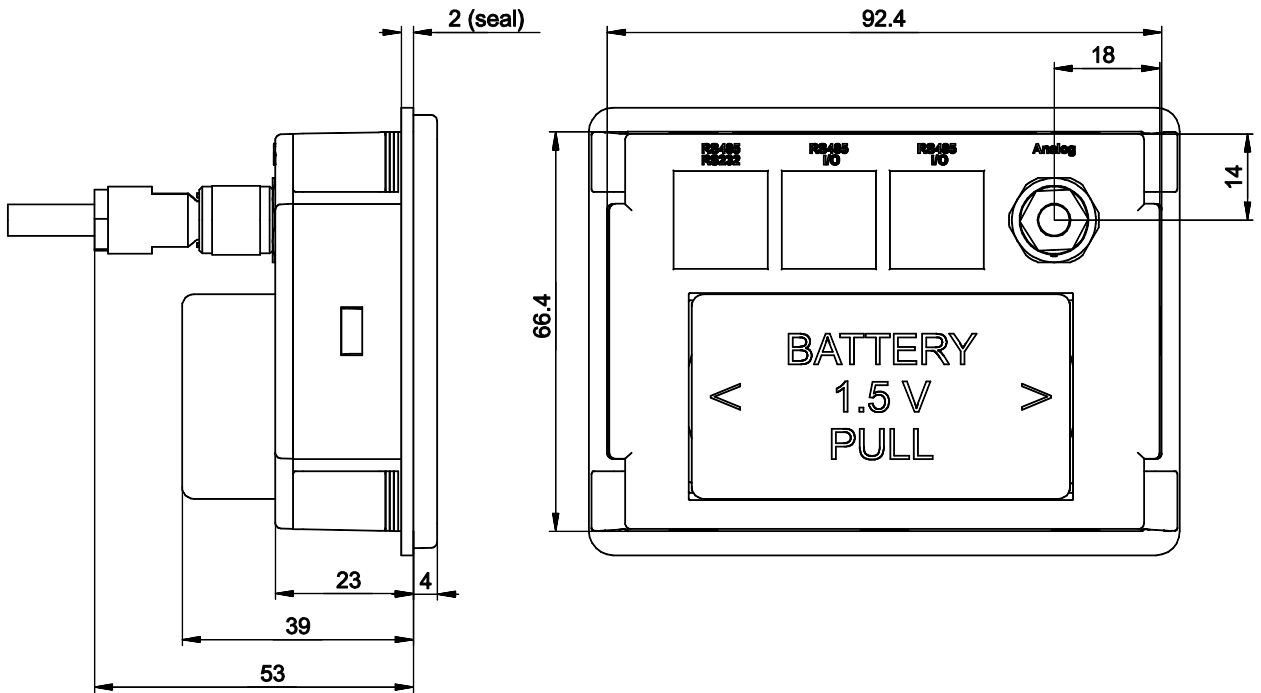

6.1.2.5 Version IZ16E-000-6-xx,x-1

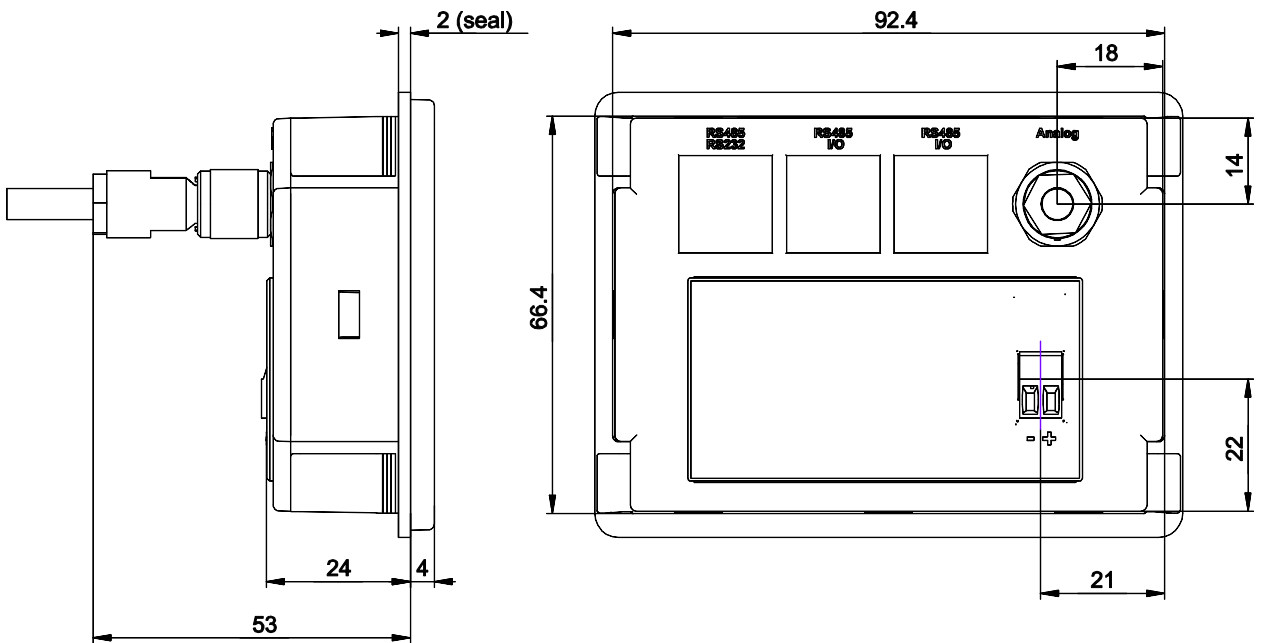

6.1.2.6 Version IZ16E-000-8-xx,x-1-AG

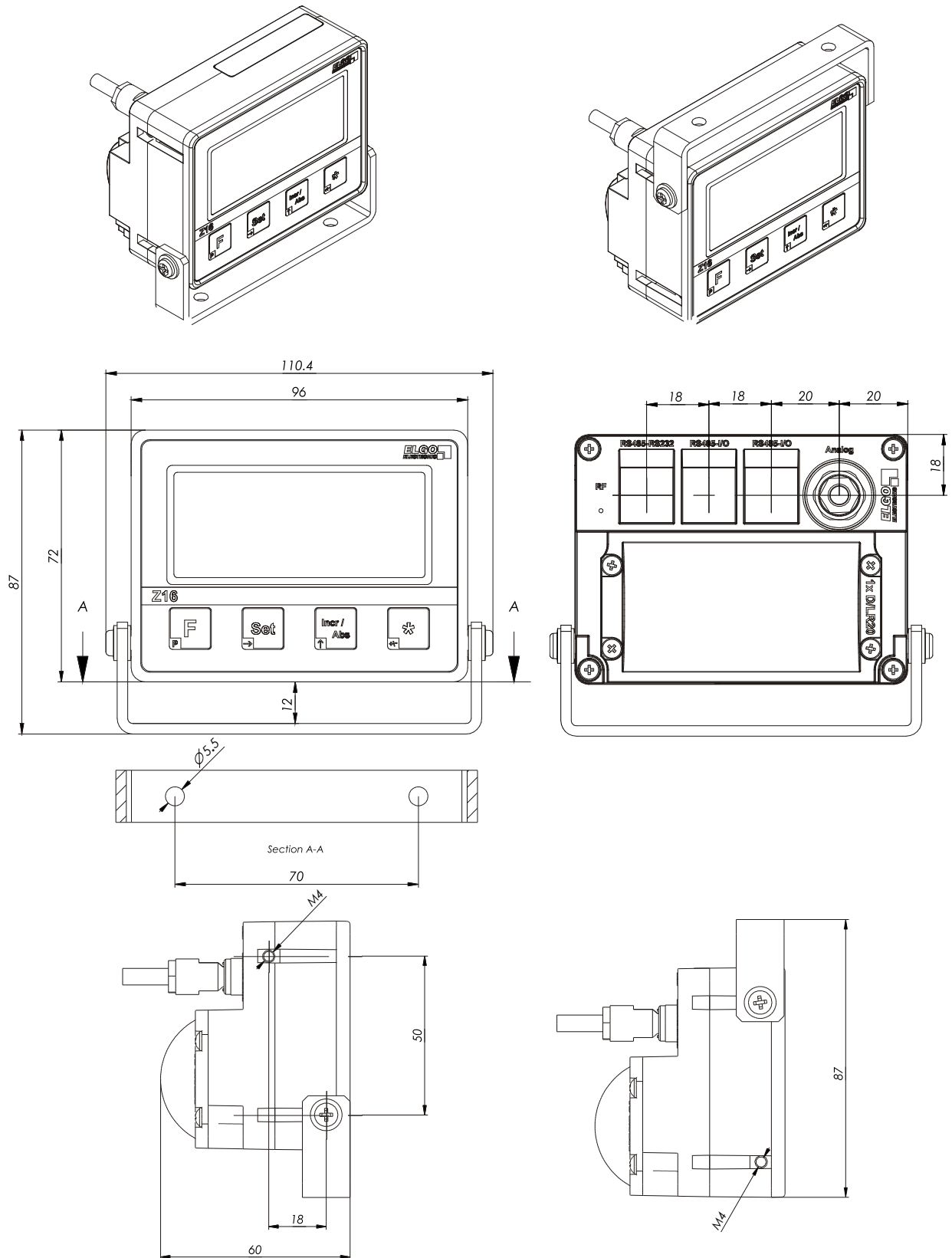

The mounting holder is adjustable in the angle, allows also lateral adjustment and can be mounted above or below.

6.1.3 Technical Data IZ16E

Position Indicator IZ16E	
LCD-Display	7 decades (digit height 14mm) With sign, battery status and measurement units
Measuring unit	mm, m, Inch or °
Perspective	12 o'clock
Keyboard	Foil with softkeys
Measuring principle	Magnetic, theoretically absolute
Measurement	linear or rotative
Power supply	1.5 V or 3.0 V (+24V on request)
Power consumption (with measuring system)	< 1 mA with 1.5V
Battery life	1...3 years (depending on the battery-type)
Operating temperature	0 °C ... + 50 °C
Storage temperature	-10 °C ... +60 °C
Humidity	max. 80 %, non-condensing
Velocity	max. 4 m/s
Housing	Norm panel housing, ABS plastic, black
Housing dimensions	W x H = 96 x 72 mm
Installation depth	30 mm -> depending on the version, see section 6.1.2 60 mm -> option AG, see section 6.1.2.6
Front panel cut out	W x H = 93 x 67 mm
Protection class front	IP 54 (when installed with sealing) IP 43 (when installed without sealing) IP 50 (option AG) IP 64 (option AG1)
Protection class back	IP 40 IP 50 (option AG) IP 64 (option AG1)

6.1.4 Power supply / Battery change

	<p>ADVERT For a long operating time, the use of commercially branded batteries is recommended.</p> <p>If all the battery icons on the LCD-Display are extinguished (see also section Fehler! Verweisquelle konnte nicht gefunden werden.), a battery change should be made as soon as possible.</p> <p>By changing the batteries strictly observe the polarity, take for orientation the markings on the battery-case!</p> <p>All data and parameters are obtained at the battery change, apart from the current actual value.</p>
---	--

All components of the series **IZ16E-xxx-1-xx,x-x** have a built-in battery-holder for a battery of the type C=LR14=baby cell (supplied).

All components of the series **IZ16E-xxx-8-xx,x-1-AG** have a built-in battery-holder with bolt down cover for a battery of the type D=LR20=MONO (supplied).

All components of the series **IZ16E-xxx-6-xx,x-x** have a pluggable 2-pole screw clamp (1.5mm²) for connection with an external battery with 1.5V or 3.0V (not supplied; as an accessory available) or as an external stabilized power supply with 1.5V / 3.0V or 24V*.

Following battery-holder configurations are possible:

- 1x Battery Type C or Type D (1.5V)
- 2x Battery Type AA / C / D parallel (1.5V)
- 2x Battery Type AA / C / D connected in series (3.0V)

Pin Assignment for plug:

PIN	FUNCTION
1	0V / GND
2	+1.5V / +3.0V / +24V*



(* only on request)

6.2 Magnetic Sensor MS 20.25

6.2.1 Dimensions of the Magnetic Sensor

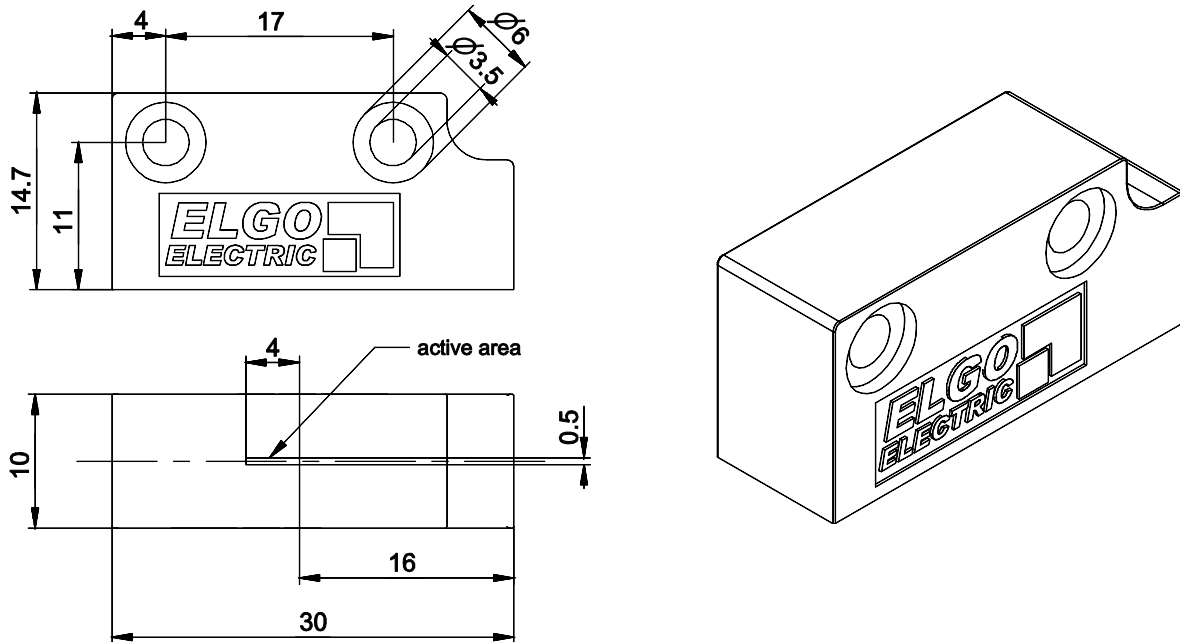

6.2.2 Technical Data of the Magnetic Sensor

Magnetic Sensor MS20.25

Pole length	2.5 mm
Sensor cable length	0.1 m ... max. 2.0 m
Sensor cable	Drag-chain suitable, 6-wires, twisted pairs and double shielded
Housing	Zinc die cast
Protection class	IP67
Operating temperature	0°C ... +50°C
Storage temperature	-10°C ... +60°C
Mounting position	User defined
Bending Radius (Cable)	min. 60mm
Repeat accuracy	+/- 2 increments
Gap Sensor/Tape	max. 1.0mm (without cover band)
Influence of external magnetic fields	External Magnetic fields > 1 mT, which directly impinge upon the sensor, can affect the system accuracy.

6.3 Magnetic Tape MB20-25

The magnetic tape contains the necessary digital information needed for linear length measurement using an ELGO length measuring systems. Basically a distinction is made between incremental and absolute measuring. The incremental measuring system consists of reading electronic, which is scanning north and south poles on the magnetic tape and is creating a Sine and Cosine signal.

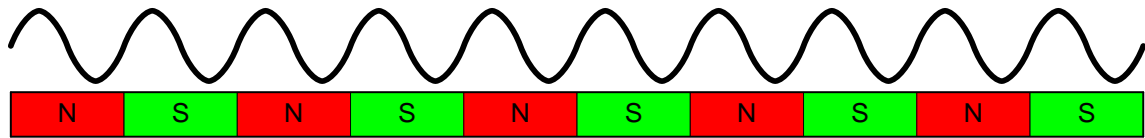

These signals are electronically interpolated, the resolution of the measuring system results of the interpolation rate and the pole length.

6.3.1 Components

In the standard case, the magnetic tape is delivered as described. It is installed by gluing it to the respective mounting surface.

The magnetic tape consists of 2 pre-assembled components (see Figure 1):

- A magnetized, flexible plastic tape (Pos. 3), which is connected with a magnetically conductive steel tape as inference band (Pos. 4) and is supplied with an adhesive tape (Pos. 5).
- A magnetized permeable cover tape (Pos. 1), which serves for the mechanical protection of the plastic tape (not required for the measurement) and is supplied with an adhesive tape (Pos. 2).

Therefore a divergent tape structure and scope of delivery is also possible (see section **Fehler! Verweisquelle konnte nicht gefunden werden.**).

The cover tape is also available separately (see section **Fehler! Verweisquelle konnte nicht gefunden werden.**).

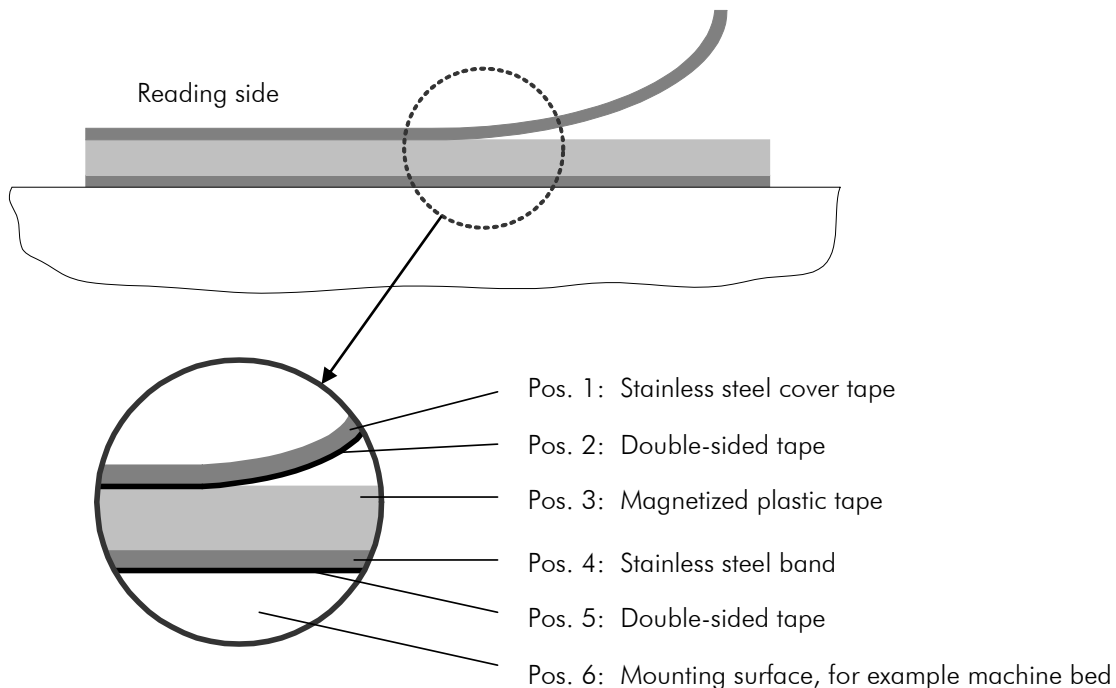

Figure 1: Components of the magnetic tape

6.3.2 Handling

In order to avoid tension in the tape, it must not be stretched, compressed or twisted. It should be stored with the magnetized plastic tape to the outside (see Figure 2), the minimum bending radius must be noted here (see section 6.3.5).

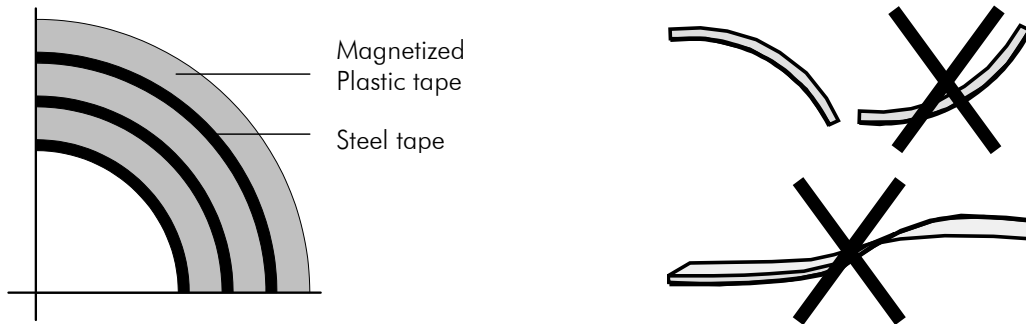
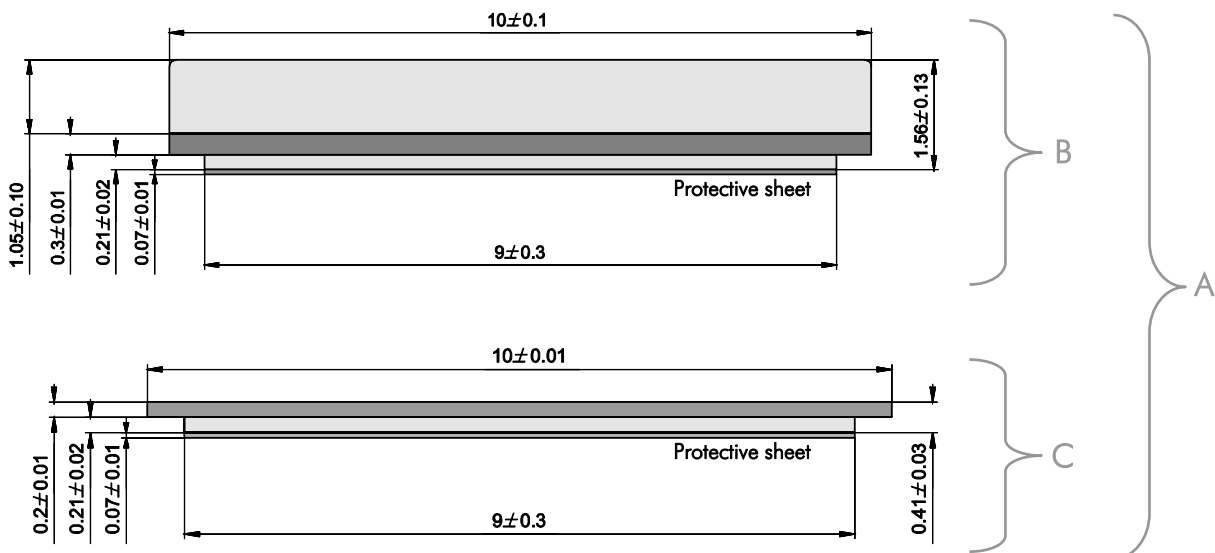

Figure 2: Handling

6.3.3 Identification

The tape is characterized by continuous with a unique serial number and type of tape. Only the scope of delivery (see section Fehler! Verweisquelle konnte nicht gefunden werden., „Option“) is not apparent on the printing.

6.3.4 Dimensions of the Magnetic Tape



A) Magnetic Tape Set: **MB20-25-10-1-R** (Standard- Delivery)

Consisting of the basic components:

B) Magnetic tape: **MB20-25-10-1-R-C** (without cover band)

C) Cover band: **SB-20-10-01-14404** (AB10)

6.3.5 Technical Data Magnetic Tape

Magnetic tape MB20-25-10-1-R

Coding	Incremental, single track
Pole length	2.5mm
Operating temperature	0 °C ... +50 °C
Storage temperature	Short term: -10 °C ... +60 °C Medium term: 0 °C ... +40 °C Long term: +18 °C
Relative humidity	max. 95 %, non-condensing
Accuracy at 20°C in mm	+/- (0.025 + 0.02 x L[m]) (L = measuring length in meter)
Thermal expansion	$\Delta L[m] = L[m] \times \alpha[1/K] \times \Delta\theta[K]$ (L = tape length in meter, $\Delta\theta$ = relative temperature change)
Linear expansion coefficient	$\alpha \approx 16 \times 10^{-6} 1/K$
Bending Radius	min. 150 mm
Available lengths	32m (up to 70m on request)
Weight of the magnetic tape	ca. 62 g/m (inclusive adhesive tape + protective sheet)
Weight of the cover tape	ca. 19 g/m (inclusive adhesive tape + protective sheet)
Influence of external magnetic fields	External magnetic fields are not allowed to exceed 64 mT (640 Oe; 52 kA/m) at the magnetic tape surface, because it can destroy and damage the magnetic tape code.
Protection class	IP67

6.3.6 Chemical resistance of the magnetic tape

Chemicals that show little or no impact:

- | | | | |
|--------------------|-----------------|---------------|---------------|
| - Formic acid | - Glycerol 93°C | - Linseed oil | - Soybean oil |
| - cotton oil | - Iso-Octane | - N-Hexane | - Lactic acid |
| - Formaldehyde 40% | - Petroleum | | |

Chemicals that show weak to moderate effects:

- | | | | |
|------------|-------------|-------------------------|------------------------------------|
| - Acetone | - Petrol | - Acetic acid 20%...30% | - Oleic acid |
| - Kerosene | - Acetylene | - Steam | - Acetic acid, glacial acetic acid |
| - Seawater | - Ammonia | - isopropyl ether | - Stearic acid 70°C |

Chemicals that show a strong impact:

- | | | | |
|------------------------|--------------------|----------------|-------------------------------|
| - Benzene | - Nitric acid | - Turpentine | - Paint solvents |
| - Carbon tetrachloride | - Trichlorethylene | - Nitrobenzene | - Hydrochloric acid 37%, 93°C |
| - Tetrahydrofuran | - Toluene | - Xylene | |

7 Type Designation

I Z 1 6 E - 0 0 0 - 1 - 0 1 . 0 - 0 - X

Series / Type: _____

I Z 1 6 E: Position Indicator with external Sensor

Version No.: _____

000 = Standard

Supply: _____

1 = integrated battery case with cover (1x Type C / LR14 / Baby)

6 = pluggable screw clamps (2-pole. / 1 mm²) for 1.5 V or 3 V

8 = integrated battery case with cover (1 x Type D / LR 20 / Mono / 1.5 V)
(No. 8 only for built-on enclosure → option 'AG')

Sensor Cable Length: _____

(maximum 2 meters)

Cable Options: _____

0 = fixed cable (Standard)

1 = pluggable round connector (threaded)

Options: _____

CAP = with integrated battery backup capacitor without actual value loss

24V = for external supply 10...30 VDC

AG = built-on enclosure with mounting holder (IP50)

AG1 = built-on enclosure with mounting holder, sealed up (IP64)

→ only for enclosure without RJ45!

7.1 Available Variants

Order Code	Description
IZ16E-000-1-xx,x-0	Integrated battery holder, fixed sensor cable outlet
IZ16E-000-1-xx,x-0-CAP	Integrated battery holder, fixed sensor cable outlet, with backup capacitor
IZ16E-000-6-xx,x-0	Screw clamps, fixed sensor cable outlet
IZ16E-000-6-xx,x-0-CAP	Screw clamps, fixed sensor cable outlet with backup capacitor (only for 1,5V)
IZ16E-000-6-xx,x-0-24V*	Screw clamps, fixed sensor cable outlet with 24V- power supply*
IZ16E-000-1-xx,x-1	Integrated battery holder, sensor cable connector
IZ16E-000-1-xx,x-1-CAP	Integrated battery holder, sensor cable connector, with backup capacitor
IZ16E-000-6-xx,x-1	Screw clamps, sensor cable connector
IZ16E-000-6-xx,x-1-CAP	Screw clamps, sensor cable connector, with backup capacitor (only for 1,5V!)
IZ16E-000-6-xx,x-1-24V*	Screw clamps, sensor cable connector, with 24V- power supply*
IZ16E-000-8-xx,x-1-AG	built-on enclosure (IP50), integrated battery holder, sensor cable connector
IZ16E-000-8-xx,x-1-AG-CAP	built-on enclosure (IP50), integrated battery holder, sensor cable connector, with backup capacitor
IZ16E-000-8-xx,x-1-AG1*	built-on enclosure (IP64), integrated battery holder, sensor cable connector
IZ16E-000-8-xx,x-1-AG1-CAP*	built-on enclosure (IP64), integrated battery holder, sensor cable connector, with backup capacitor

(* only on request) (xx,x = sensor cable length in meter)

Sensor- Standard-Cable-Length: 00.2 / 00.3 / 00.5 / 00.6 / 00.8 / 01.0 / 01.1 / 01.5 / 01.8 / 02.0 m

8 Type Designation Magnetic Tape

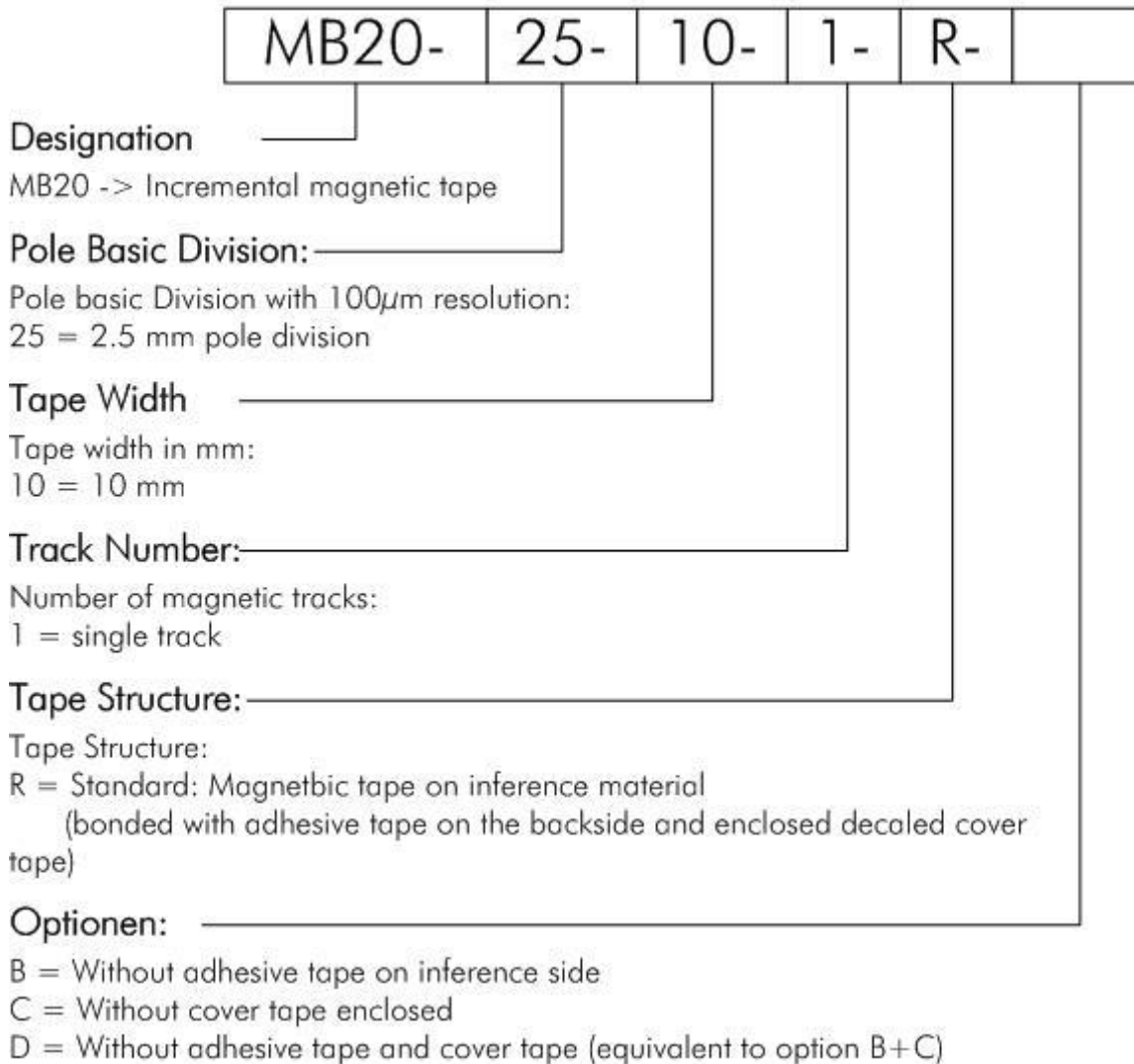

8.1 Available Variants

Order Code	Description
MB20-25-10-1-R	Magnetic tape in the standard package with cover band and adhesive tape
MB20-25-10-1-R-B	Without tape on the back side/ with enclosed adhesive tape
MB20-25-10-1-R-C	With tape on the back side/ without cover band
MB20-25-10-1-R-D	Without tape on the back side/ without cover tape

Available lengths: 0.5m ... 70m
Order example: MB20-25-10-1-R / L=1.5m





	<p>ADVERT! For technical reasons, the measurement cannot be directly carried to the end of the tape; there should always be a gap of 50mm to adhere to the cutting edge.</p> <p style="text-align: center;">→ Tape length = Measuring length + 100 mm ←</p>
---	--

9 Installation and Initial Start-up

	<p>ADVERT</p> <p>Please read the operating instructions carefully before using this device! Installation instructions must be observed! In case of damage caused by failure observing the installation instructions, the warranty will be invalidated.</p> <p>The ELGO Electronic GmbH & Co. KG and the subsidiaries are not liable for injury to persons, property or financial loss, which can be by faulty material on the device and / or incurred by the related components. We assume no liability for damages!</p> <p>The operator is obliged to take appropriate security measures and implement it.</p> <p>The commissioning should only be performed by qualified and authorized by the operator and instructed personnel.</p>
---	---

9.1 Operational Environment

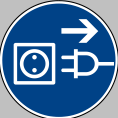
	<p>WARNING!</p> <p>Do not use the device in explosive or corrosive environments!</p>
---	---

	<p>CAUTION!</p> <p>The electrical connections are made by suitably qualified personnel in accordance with local regulations.</p>
	<p>The device is designed for switchboard mounting. During the work on the switchboard, all components must be free of tension if the danger exists, that energized parts can be touched. (Finger protection)</p>
	<p>Wiring may only be energized!</p> <p>Thin wire cable strands are equipped with ferrule!</p>
	<p>Before switching on all ports and connectors are to be reviewed!</p> <p>The device must be mounted that it is protected against harmful environmental influences such as splashing water, solvent, vibration, shock and severe pollution and also the operating temperature is to maintain.</p>

9.2 Interferences

If errors cannot be corrected with the following instructions please contact the manufacturer (see last page).

	<p>NOTE</p> <p>Device, connection cables and signal cables must not be installed directly next to interference, which have strong inductive or capacitive interference or strong electrostatic fields!</p> <p>External interference can be avoided by a suitable cable routing.</p>
---	--

	<p>Signal wires and cables are principally laid separately from the LASTSTROMLEITUNG and keep a safety distance of at least 0,5m to inductive or capacitive interference sources such as contactors, relays, motors, switching power supplies, clocked controllers, etc.!</p> <p>If faults occur despite of compliance of all the described items above, it must proceed as follows:</p> <ol style="list-style-type: none">1. Attachment of RC elements of contactor coils of AC contactors (e.g. 0.1 μF / 100Ω)2. Attachment of free-wheeling diodes using DC inductors3. Attachment of RC elements of individual motor phases (in the terminal box of the engine)4. Do not connect safety ground and reference potential5. Pre-connecting a mains filter on the external power supply6. Use of sheet metal or metalized shielding housings
---	--

9.3 Mounting description / Installation of the Indicator

9.3.1 Installation IZ16E-000-x-xx.x-x in the front panel

The mounting of the device in the front panel is achieved by four slide clips ("Snap-In Mounting").

For this purpose no tools or special tools are needed.

The IZ16E comes with a separate seal. The mounting with seal (optional) increases the protection class for splash water proof and dust protection. With an installation that is opened on the back, the openings on the side of the IZ16E must be additionally closed with the arranged stickers (dust protection).

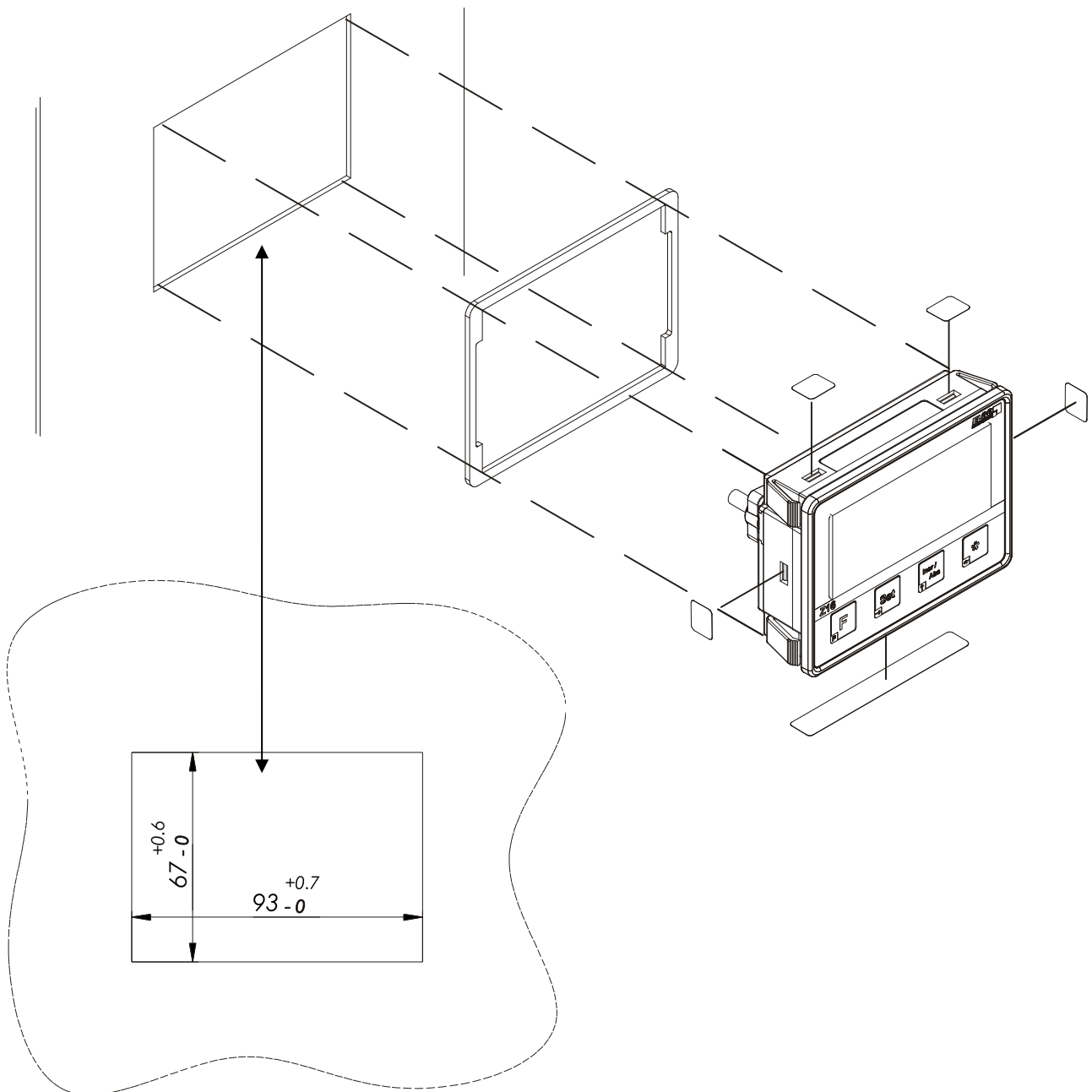

9.3.2 Installation IZ16E-000-x-xx.x-x with a mounting angle

The mounting angle is available in the accessory, with reference to part 11.1.
The detent of the device in the mounting angle is achieved by four slide clips ("Snap-In Mounting").
For this purpose no tools or special tools are needed. The **IZ16E** is delivered with a separate seal.
The mounting of the seal is necessary for the correct hold in the mounting angle.
The openings on the side of the **IZ16E** must be closed with the enclosed stickers (dust protection).

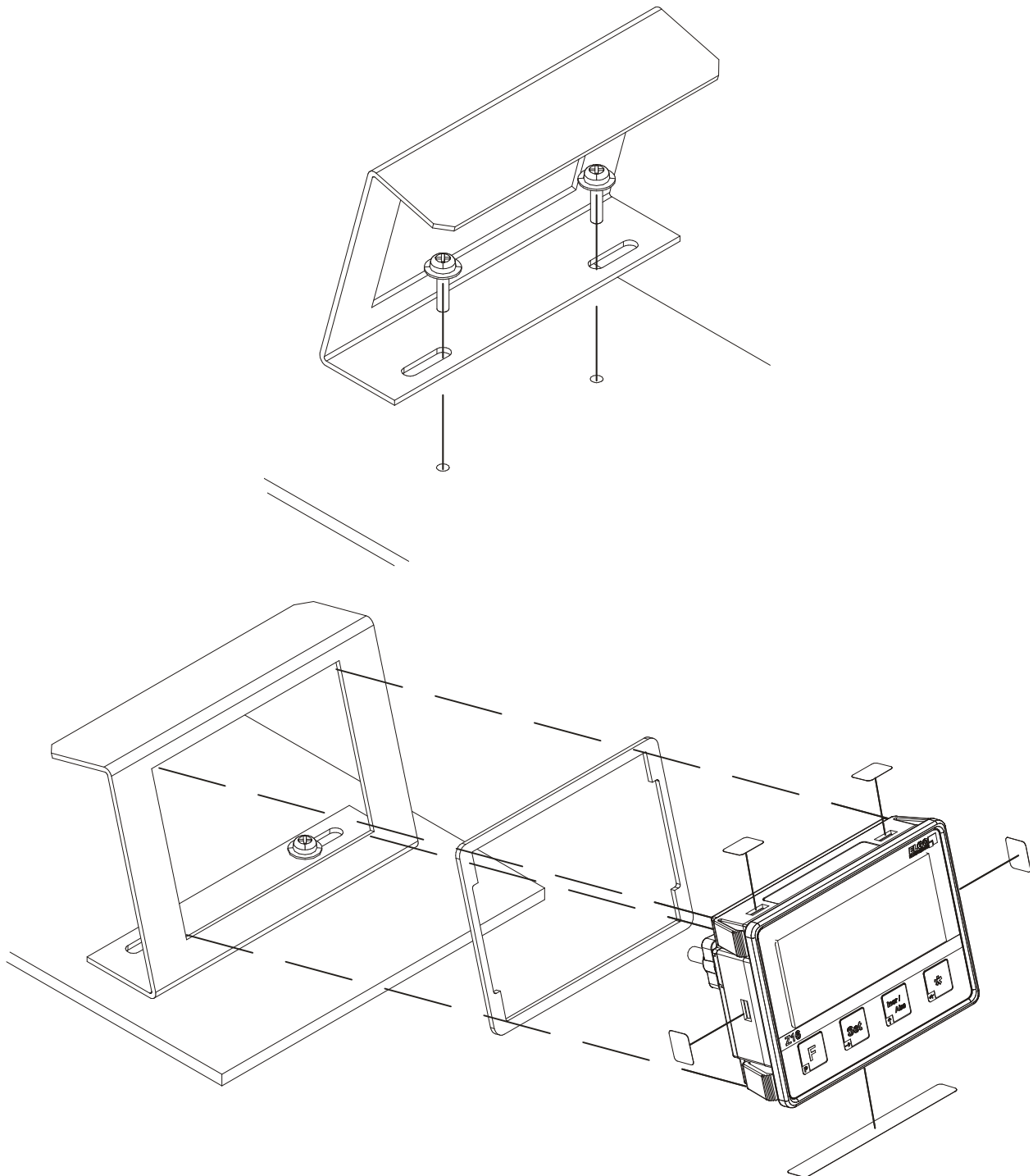

9.3.3 Installation IZ16E-000-8-xx.x-1-AG

Step 1: mounting the battery

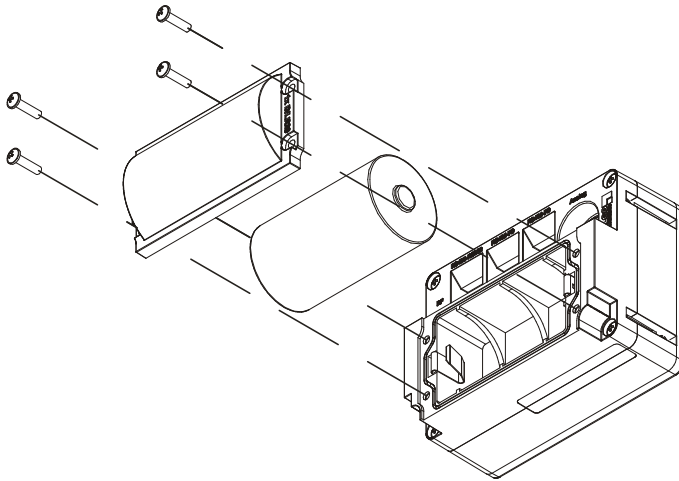

Step 2: fixing the mounting clamp

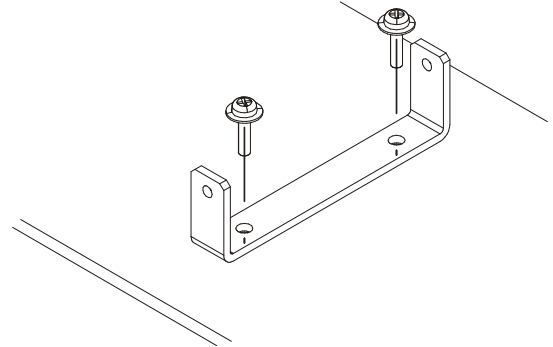

Step 3: screw & underlay right

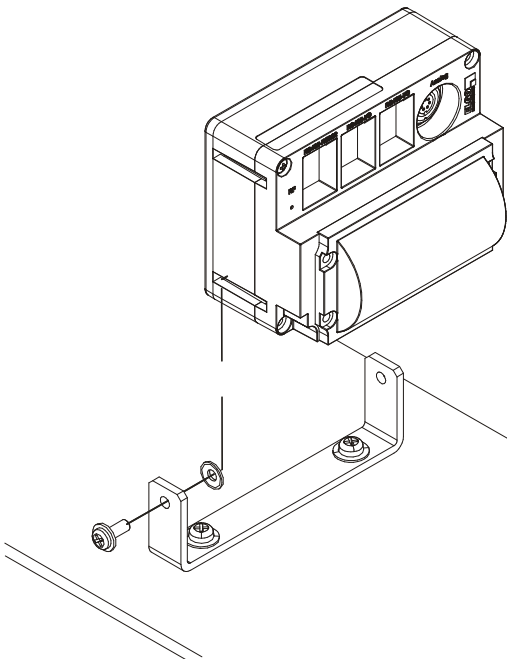

Step 4: screw & underlay left

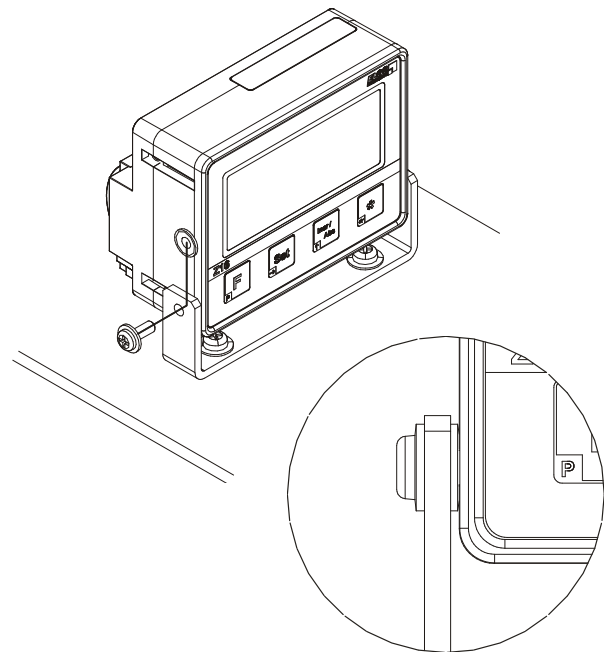

9.4 Activating the device

After starting the operating voltage (e.g. insert the battery) the device starts automatically.

9.5 Description of mounting / Installation of the magnetic sensor

With the use of two screws type M3, the magnetic sensor can be mounted with the help of the fastening bores. (see chapter 6.2.1).

The allowed distance from the sensor to the magnetic tape surface is noticed in the technical information (see chapter 6.2.2).

Furthermore, there are following maximum tolerances of angles, which have to be ensured over the complete section of measurements:

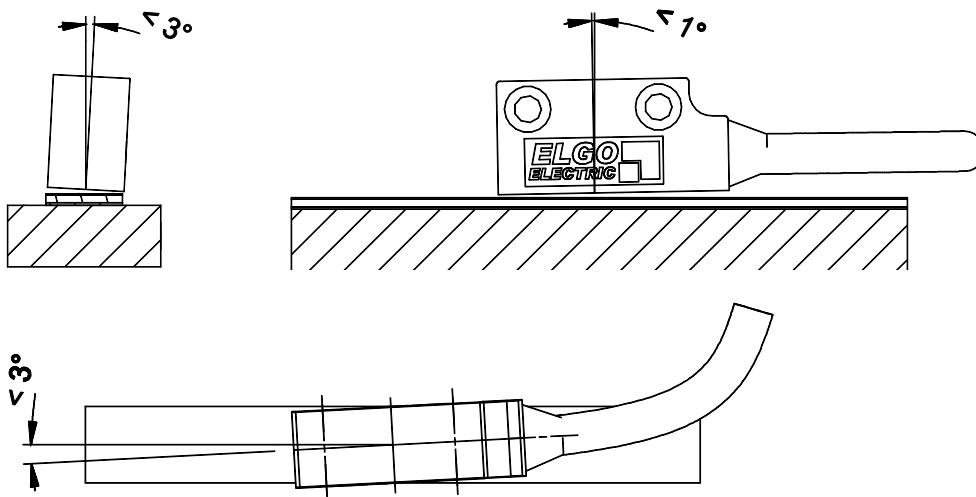

The cable has to be placed so that there is no risk of damage (e.g. through pulling or crushes). On demand, it makes sense to use a drag chain or a protective tubing to achieve a strain relief.

9.6 Installation of the magnetic tape

	<p>NOTE External Magnetic Fields</p> <p>The influence of the magnetic tape by magnetic fields is to be avoided! The magnetic tape should not come into direct contact with other magnetic fields (e.g. permanent magnets, holding magnets, electromagnets, magnetic stands)! Irreparable damage is likely to affect either the accuracy or even the function!</p>
---	--

9.6.1 Processing note for the bonding

The included adhesive tapes are coated on both sides with a modified acrylic adhesive and stick well on clean, dry and smooth surfaces. They are characterized by a high initial tack and good adhesive strength to high- and low-energy surfaces (e.g. PE, PP), high shear and peel strength and a good humidity, UV and aging resistance. The surface should be very clean if the surroundings are very dirty.

	<p>NOTE Surface treatment</p> <p>In order to guarantee an optimal adhesion all the anti-adhesive contaminants (e.g. oil, grease, dust, release agents, etc.) have to be removed by a residue evaporating solvent. Suitable for this are for example Ketones (acetone) or alcohols. Typical solvents for cleaning are a 50/50 Isopropyl alcohol/water-mixture or heptanes. LOCTITE or 3M offer such solvents as a substrate cleaner. Note if dealing with solvents necessarily respond the warning of the manufacturer!</p> <p>For materials such as copper, brass, etc. the surfaces should be sealed to prevent oxidation.</p>
--	--

	<p>NOTE Pressure</p> <p>The strength of the adhesion is directly dependent on the contact, which the adhesive developed to the bonded surface. Therefore, sealing with the maximum possible pressure, aids such as pressure roller or roller are to recommend (Opt. pressure 4...5 kg/cm² adhesive surface).</p>
---	--

	<p>NOTE Adhesive temperature</p> <p>The best application (adhesive) temperature is between +18 °C and +30 °C. Avoid colder sticking surfaces than +10 °C, because in this case the adhesive becomes too hard and perhaps a sufficient immediate adhesion might be difficult to achieve. After proper sticking the stability of the connection is ensured also when the temperature is below zero. The final adhesive power is empirical achieved after approximately 72 hours at a temperature of +21 °C.</p>
---	--

9.6.2 Cutting and Sticking

Before starting the gluing, the magnetic tape and the cover band need to be cut to the exact length:

Length of the magnetic tape = Measuring length + 100 mm

Length of the cover tape = Measuring length + 100 mm + Overlap*



ADVERT

In an unprotected environment, there is the danger that the cover band can be peeled!

Therefore:

Use magnetic tape end caps or let the cover tape overlap* at the end of the tape and for example laterally fix with screws.

Preferably, the magnetic tape should be stuck into a nut or aligned to an edge.

By bonding the magnetic tape, the markings on the tape and the sensor head are to be respected. Improper installation does not provide correct values. The mounting needs to be co-planar to the mounting area or the place you intend to measure. Ripples deteriorate the measurement accuracy!

Installation steps:

1. Clean the surface thoroughly
2. Remove the protective tape at the adhesive tape
3. Glue the tape with large pressure
4. Clean carefully the magnetic tape surface
5. Remove the protective sheet of the adhesive tape from the cover band
6. Stick the cover tape with large pressure
7. Secure the ends of the cover tape against detachment



TIP

By assembling a long magnetic tape the protective sheet of the adhesive tape should be only removed for a short section to fix the magnetic tape at the desired position.

Then the protection can be removed slowly from the remaining length of the protective sheet under a simultaneous pressure of the tape.



ADVERT

A pre-glued magnetic tape is destroyed after removal and cannot be used again!

10 Structure and Function

The operation of the device is divided into the parameter level (see section 10.3), the operator level (see section 10.5) and the initialization level.

All operating parameters can be put in through the **parameter level** (see section 10.3.6).

At the **operator level** the basic functions are available (depending on the software version).

In the **initialization level** only the basic operations such as sensor calibration or resetting the unit will run on default parameters (company setting).

All entries are made solely on the 4 front-mounted buttons or keyboard shortcuts of those, the displays occur via the integrated LCD.

10.1 Overview-Display

The following display icons or segments of the LCD-display are used in this software version:

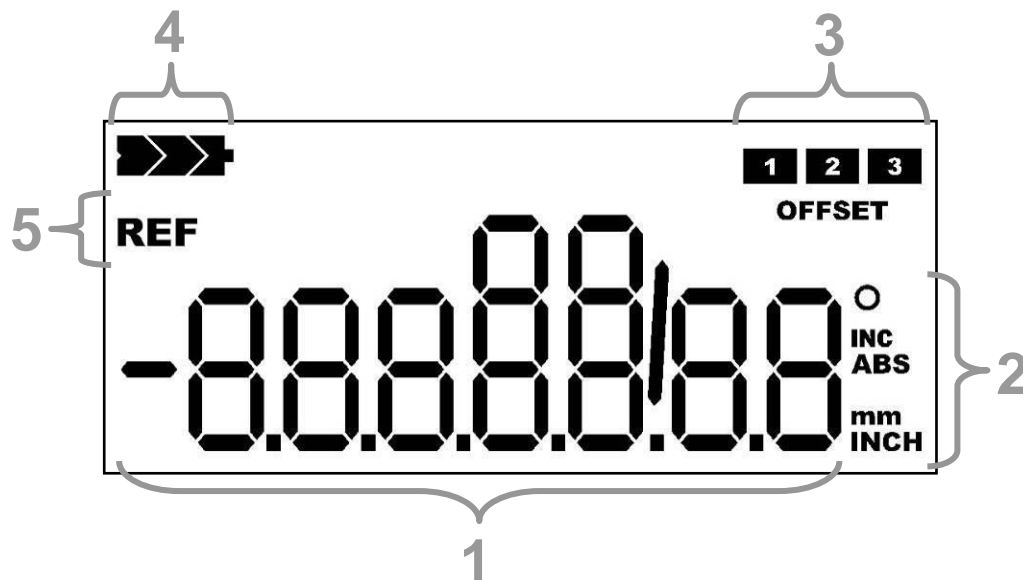

1	Segments for numeric and text display (including signs, decimal points, fraction display)
2	Symbols for units and display mode
3	Icons for active tool-offsets 1 ... 3
4	Battery-Status Icons
5	REF symbol: unit needs to be referenced





For different applications the symbol may be changed for the unit by parameter (P02), e.g. the „°“ - symbol for angle measurement (see section 10.3.6).



The standardization of the indicator value must be done manually with the corresponding multiplication factor (P08) and the decimal point (P03) (see section 10.3.6).

In the Inch-mode an additional fraction display is available.

10.2 Key-Overview

The function of the keys in the parameter level is shown on the button in the dark box on the left below the function at the operating level is shown in the bright field size:

Keys	Function at the operating level (see 10.5)	Function at the parameter level (see 10.3)
	Base-keys for keyboard shortcuts	Parameter level enable/disable
	Fraction display in the Inch mode	Next digit (decades) select
	Incremental enable/disable	Increases the value by 1
	Tool-offsets enable/disable	Sign change

Keys	Function at the initialization level
	If the device is activated the calibration is triggered
	If the device is activated the parameters are reset to factory settings and causes a calibration

10.3 Parameter Level

→ Adjusting settings

10.3.1 Activate the Parameter Level



Hold it for about 3 seconds / then press each 1x

The parameter level is activated with this key. After about 3 seconds the display shows „P01“ for the first parameter. When the button is actuated again, the corresponding parameter value is displayed, which can then be changed. With the help of this all parameters are successfully selected.

10.3.2 Election of the Decade



1x pressed

With this key the decade will be advanced by a passage from left to right. The selected, changeable decade is flashing on the display.

10.3.3 Change Value



1x pressed

With this key the value in the selected decade is always increased by 1 (0...9 or 0/1)

10.3.4 Change Sign



With this key the sign can be changed for some parameters. (Negative sign is only possible if the value is not ZERO)

10.3.5 Leave Parameter Level



Press it for about 3 seconds in the parameter level

All parameters will be retentively stored in the internal flash memory when leaving the parameter level.

10.3.6 Parameter list

Parameter:	Description:	Default:
P01: A	System configuration: A = 0: Counting positively A = 1: Counting negatively	0
P02: A	Display mode (affect only the display of symbols!) A = 0: mm-Mode / Display symbol „ mm “ A = 1: Inch-Mode / Display symbol „ Inch “ A = 2: mm-Mode / Display symbol „ m “ A = 3: mm-Mode / Display symbol „ ° “ A = 4: mm-Mode / Display non symbol	0
P03: A	Decimal point (0 ... 4) → only for mm-Mode	2
P05: ABC	Keylock: A: Key „Set“ (0= activated / 1= deactivated) B: Key „Incr/Abs“ (0= activated / 1= deactivated) C: Key „*“ (0= activated / 1= deactivated)	000
P07: A	Resolution: (starting with Firmware V1.50) A = 0: Resolution 0,01 mm A = 1: Resolution 0,1mm	0
P08:	Multiplication factor (0,0001 ... 9,9999)	1,0000
P09:	Reference value (-9999999 ... +9999999)	0
P10:	Offset 1 (-9999999 ... +9999999)	0
P11:	Offset 2 (-9999999 ... +9999999)	0
P12:	Offset 3 (-9999999 ... +9999999)	0
P13: A	Configuration Offset (0...3) A = 0: offset cannot be activated A = 1: offset 1 can be activated A = 2: offset 1 & 2 can be activated A = 3: offset 1 & 2 & 3 can be activated	3
P90:	(without function)	0
P99:	Indicator in the company version	x.xx

10.4 Initialization Level

→ Resetting the parameter and calibration

10.4.1 Calibration

	<p>ADVERT The calibration is already factory-made and must not run again normally.</p> <p>In a few cases a re-calibration of the device after the installation can achieve an advancement of the accuracy, because with a re-calibration the additional mounting factors (angular deviation, parallelism, etc.) are included.</p> <p>Caution: The magnetic sensor must be in the maximum distance range on the tape during the calibration.</p>
---	--

⇒ Switch off the device (remove battery or remove plug)



⇒ While pressing the key the device is turning on again

The sensor calibration is initiated and „CAL 0“ is displayed. The sensor now has to be moved slowly in a direction on the magnetic tape, the process of the calibration is shown by the display „CAL 1 ... CAL 4“. After finishing the calibration the device will start automatically in the operator level.

If you receive an error code “ERROR 1 ... ERROR 10” after the calibration, then the installation of the sensor has to be verified and the calibration has to be repeated.

10.4.2 Load the Default Parameters and simultaneous Calibration

	<p>ADVERT Already changed parameters will be overwritten by the default parameter! If it is necessary write down the setting before.</p>
---	---

⇒ Switch off the device (remove battery or remove plug)



⇒ While pressing the key the device is turning on again

All parameters are reset to factory settings. Furthermore the sensor calibration is triggered.

→ Approach see on chapter 10.4.1

10.5 Function at the Operator Level

→ Working with the device

10.5.1 Actual Value to Reference



Keys 1x press at the same time

With this shortcut, the actual value (display value) on the adjustable reference value is set (in absolute mode only possible when the offset is not enabled).

The reference value can be entered with the parameter **P09**.

10.5.2 Direct entry to value to reference

(Function is possible at firmware 1.30)



Keys 1x press at the same time

With this key combination, the value to reference **P09** can be entered without switching into the parameter level. (see on chapter 10.3)

After pressing the keys for approximately 3 seconds, the display shows the text "P09".

If the keys are released the value to reference **P09** appears, and this value can also be changed in the parameter level.



Key 1x press to save the value to reference

10.5.3 Switching incremental or absolute



1x pressed

With this key the indicator is switched from absolute mode to incremental mode:

→ The display value is temporarily set to ZERO, the symbol „INC“ appears in the display.

Actuating the key again the absolute is activated and the symbol "ABS" is displayed.

10.5.4 Activation Offset Measurements



1x pressed

This key enables/disables each of the three adjustable offset dimensions (only possible in the absolute mode). In each case an offset is added to the display value.

The activation of an offset level is indicated by the symbols **1**, **2** or **3**.

The offset measurements can be entered in the parameter **P10**, **P11** and **P12**.

Additionally, parameters can be determined with **P13**, whether and how many offset measurements can be selected.

10.5.5 Fraction Display in the Inch-Mode



With this key the display can be changed in the Inch-mode (parameter $P02 = 1$) as follows:

1x key pressed:	Display Inch- fraction display	1/64 Inch
1x key pressed:	Display Inch- fraction display	1/32 Inch
1x key pressed:	Display Inch- fraction display	1/16 Inch
1x key pressed:	Inch- Decimal Display	0.001 Inch

etc.

11 Accessories

11.1 Mounting angle

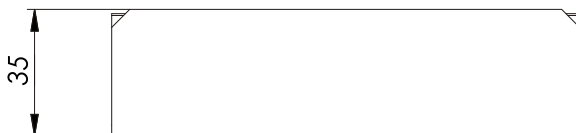
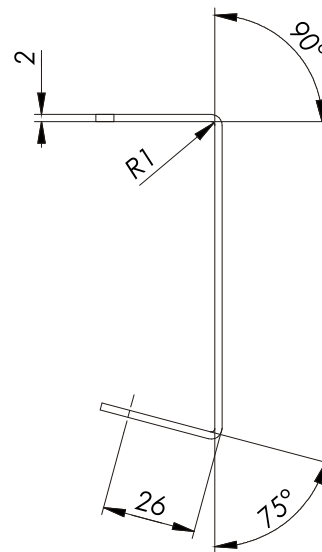
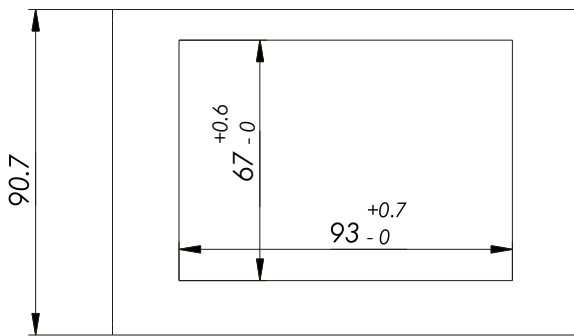
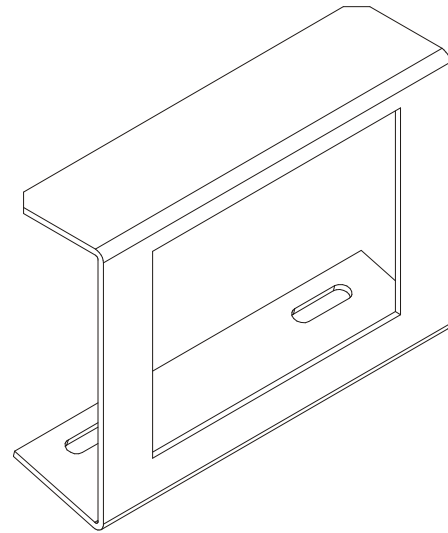
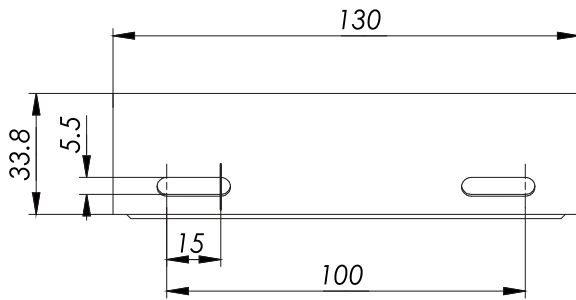

Order Code	Description
mounting angle IZ16E	Steel sheet, 2mm, zincd

11.2 Battery Holder

Assembly version:

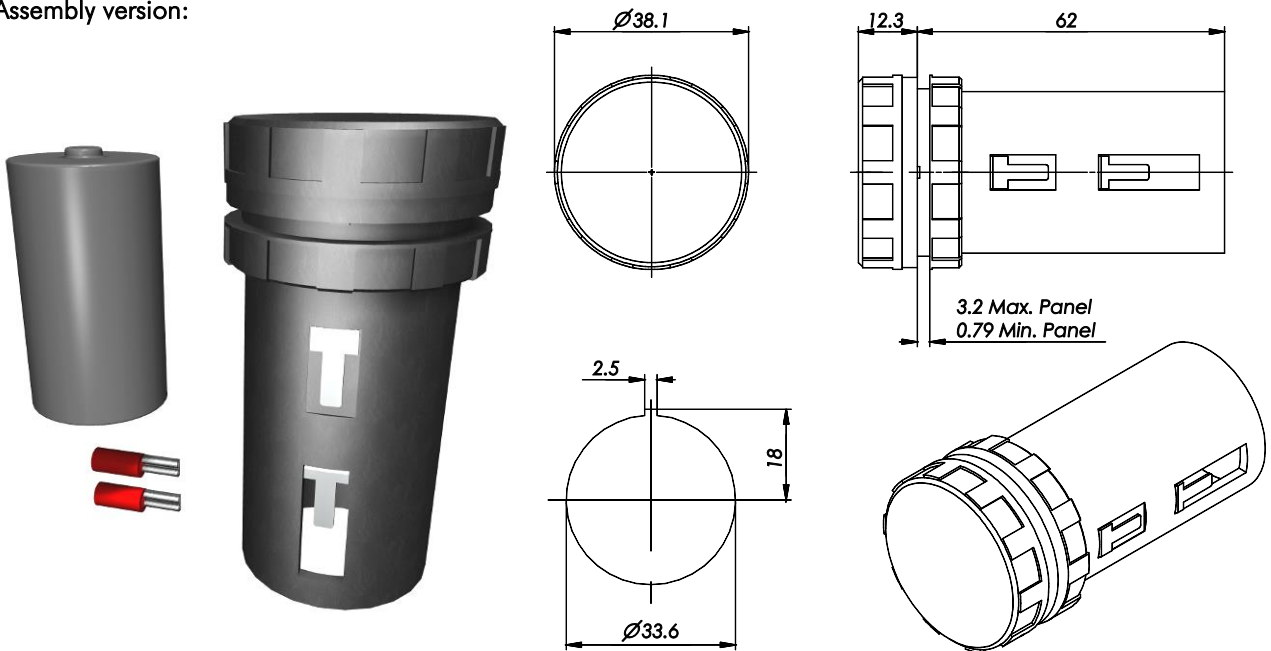

Open version:

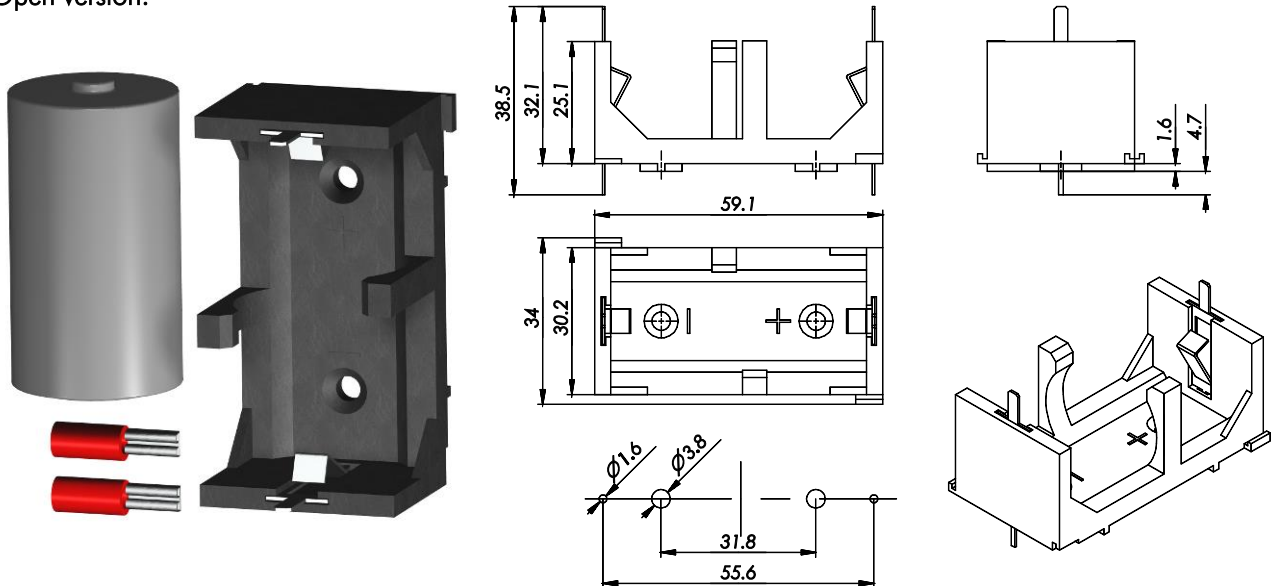

Order Code	Description
battery holder-set 1xC Assembly	inclusive battery holder (Type C), battery and 2x cable shoes
battery holder-set 1xC Open	inclusive battery holder (Type C), battery and 2x cable shoes

11.3 Cover Band individual

Drawings see section 6.3.4 .

Order Code	Description
SB-20-10-01-14404 (AB10)	Cover band, 10mm wide, single with double-sided adhesive tape

11.4 Aluminum Guiding Rail

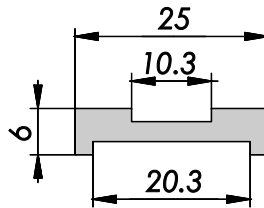

Order Code	Description
FS-20.25-xxxx (xxxx = Length in mm)	Aluminium rail with pre-glued magnetic tape MB20-25-10-1-R
FS-xxxx (xxxx = Length in mm)	Aluminium rail with 2 slots for embedding a 10 mm or a 20 mm wide magnetic tape. Without magnetic tape!

The guiding rail is available up to a maximum length of 2000 mm.

11.5 Guiding Wagon for Guiding Rail

It is the ideal complement to the guiding rail.

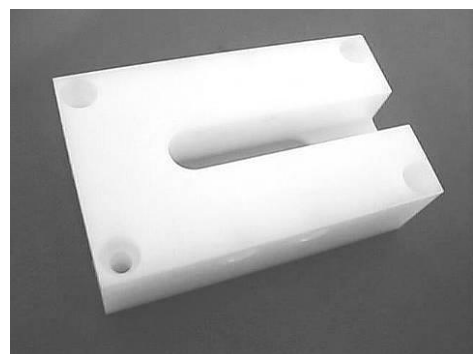

Order Code	Description
FW-20.60	Guiding wagon for a guiding rail made of special plastic (dimensions: L x W x H = 80 x 48 x 33mm)

11.6 Magnetic Tape End Cap

The magnetic tape end cap is offering the optimal protection against the peeling of the magnetic tape/ cover band. (see chapter 9.6.2)

Furthermore, in the working area the risk of injury by any existing sharp edges is minimized with the end caps.

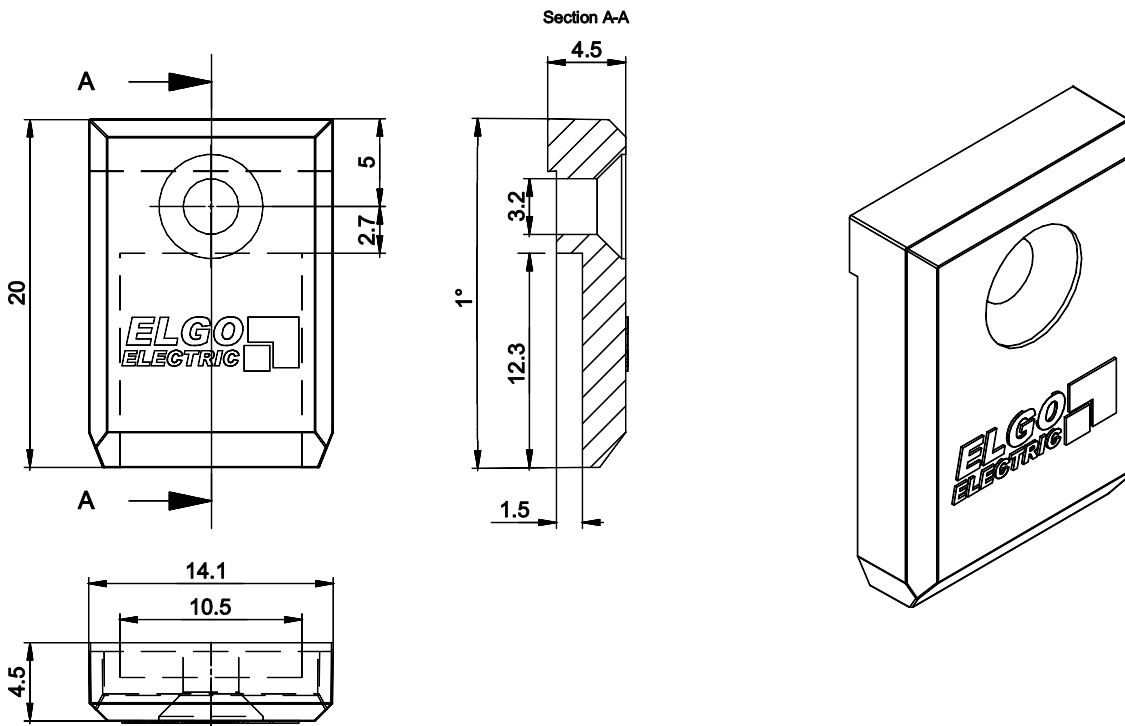
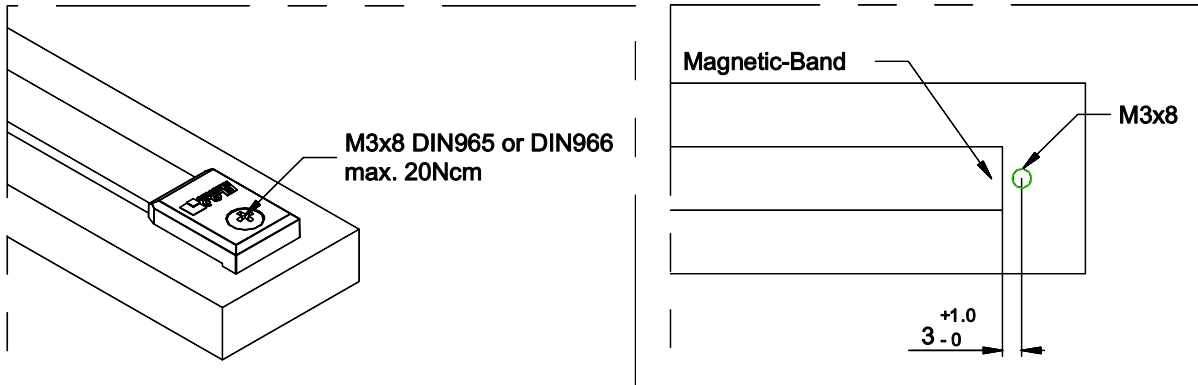

Order Code	Description
MB End Cap 10mm / single	Single end cap, loosely packed
MB End Cap 10mm / SET	Set, consisting of 2 end caps and 2 countersunk screw M3X8 Philips packed in mini-grip-bags

12 Interferences

The following chapters describe possible causes for malfunction and the instructions to correct them.

12.1 Safety



WARNING!

Risk of injury by improper disposal!

Improper disposal can lead to severe disturbance to persons or property.

Therefore:

- Any work to rectify the fault may be performed only by qualified and adequately instructed personnel
- Before starting to work ensure sufficient space of mounting
- Paying attention to orderliness and to cleanliness at the mounting area, loose parts and tools, which are lying on each other or lying around, are sources of accidents

If components need to be replaced:

- Pay attention of proper mounting of the spare parts
- Install all fasteners correctly again
- Before restarting ensure that all covers and guards are properly installed and working correctly

12.2 Restarting after fault clearance

Once you resolve the failure:

1. Where appropriate, reset the emergency stop device
2. Where appropriate reset the fault message to the parent system
3. Ensure that there are no persons in the danger zone
4. Proceed in accordance with the instruction of section 9

13 Maintenance

The device is maintenance-free.

**WARNING!**

Hazard due to improper maintenance!

Improper maintenance can result to serious personal injury or property damage.

Therefore:

Maintenance work must be performed only by qualified and authorized by the operator and instructed personnel.

14 Cleaning

**WARNING!**

The system should be cleaned with damp cloth, do not use aggressive cleaning products.

**ADVERT**

The surface of the magnetic tape can be cleaned with string contamination by dust, shavings, humidity, etc. occasionally with a soft cloth.

With a strong pollution of the magnetic tape by magnetic metal shavings measurement errors or malfunctions are possible.

15 Index

A

Aktivierung	30
Aluminum Guiding Rail.....	42
Angle Measurement.....	10, 11
Applications.....	10

C

Calibration	37
Cause of Risks.....	6

D

Demounting	5
Dimension Magnetic Tape	20
Dimensions.....	12
Dimensions Magnetic Sensor.....	18
Disposal	5

E

Explanation of Symbols.....	4
-----------------------------	---

F

front panel thickness.....	12
Front View.....	12

G

Guarantee	5
-----------------	---

I

Identification	12, 20
Initial Start-up	25
Installation	25

Installation Magnetic Sensor.....	28
Interferences.....	26

M

Magnetic Tape	19
Montage Magnetsensor.....	30

O

Operational Environment	25
-------------------------------	----

P

panel cut out	12
Parameter Level	35
Parameter List	36
Product Features.....	9
Protective Equipment	6

R

resolution	9
------------------	---

S

Safety	6
Safety Instructions	4
Storage	8

T

Technical Data	12
Transport.....	8

W

Warranty	5
----------------	---

16 Document History

Rev.	Date	Author	Changes
0	26.11.09	DW	Translation
1	23.04.10	DN	parameter P09 direct entry function 10.5.2 Fehler! Verweisquelle konnte nicht gefunden werden. included. The mistake in the pin configuration 6.1.4 has been rectified (3,0V instead of 3,3V)
2	14.06.10	DN	Upgrading: Option built-on enclosure 6.1.2.6 Upgrading: accessory mounting angle 11.1 Upgrading: mounting description 9.3
3	21.06.10	BB	Adjustment: explanation of symbols 1.2 Upgrading: repeatability 6.2.2
4	20.11.19	CD	Cable option 1 in Chapter 7 corrected

