

Operating Manual

SERIES LIMAX2

Magnetic Absolute Shaft Information System for Elevators
(Translation of the original operating manual)

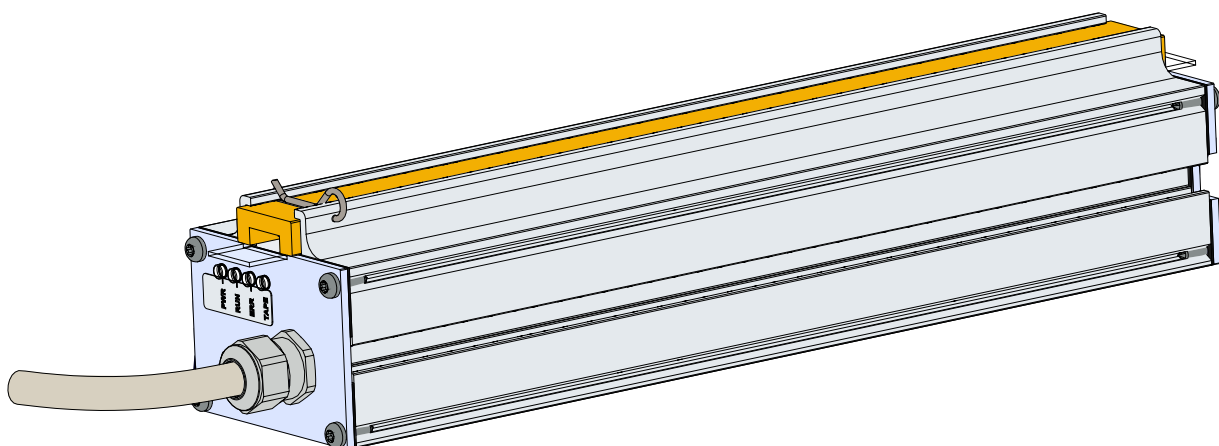

- Robust measuring principle for usage in rough environments
- Insensitive against dirt, smoke and humidity
- Simple and flexible installation
- High accuracy and reproducibility
- Absolute position measurement with a length up to 260 m
- Resolution up to 1 mm, higher resolution on request
- Absolute position is always directly available
no referencing even after long power failure
- Compatible with many established controls with absolute encoder interface
- Available interfaces:
SSI, CAN, CANopen (DS406, DS417), RS422, RS232, PROFIBUS

Publisher ELGO Batscale AG
Föhrenweg 20
FL-9496 Balzers

Technical Support  +49 (0) 7731 9339 - 0
 +49 (0) 7731 2 88 03
 support@elgo.de

Document- No. D-103920

Document - Name LIMAX2-00-MA-E_06-20

Article Number 799000350

Document- Revision Rev. 1

Issue Date 2020-02-06

Copyright © 2020, ELGO Batscale AG

1 Contents

1	Contents	3
2	List of Figures.....	5
3	List of Tables	5
4	General.....	6
4.1	Information Operating Manual	6
4.2	Explanation of Symbols.....	6
4.3	Statement of Warranties.....	7
4.4	Demounting and Disposal	7
5	Safety	8
5.1	General Causes of Risk.....	8
5.2	Personal Protective Equipment.....	8
5.3	Conventional Use	9
6	Transport and Storage	10
6.1	Safety Instructions for Transport, Unpacking and Loading	10
6.2	Handling of Packaging Material	10
6.3	Inspection of Transport	10
6.4	Storage	10
7	Product Features	11
7.1	Functional principle.....	11
7.2	Sensor Construction	11
8	Technical Data	12
8.1	Identification	12
8.2	Dimensions Sensor Standard.....	12
8.3	Dimensions Sensor Option unguided	13
8.4	Dimensions Sensor Option PNO	13
8.5	Dimensions Magnetic Tape	14
8.6	Technical Data Sensor	14
8.7	Technical Data Magnetic Tape.....	15
9	Installation and First Start-Up.....	16
9.1	Operating Area	16
9.2	Description installation of the Sensor.....	17
9.3	Description installation / Mounting of the Magnetic Tape	18

10	Connections and Interfaces	22
10.1	LED's (Operating status and notices)	24
10.2	CAN Interface	24
10.3	SSI Interface.....	31
10.4	RS232 / RS422 / RS485*	32
10.5	Option Unguided	35
10.6	Option PROFIBUS Interface	36
11	Disturbances, Maintenance, Cleaning.....	38
11.1	Fault Clearance.....	38
11.2	Re-start after Fault Clearance.....	38
11.3	Maintenance.....	39
11.4	Cleaning	39
12	Type Designation	40
12.1	Control specific Sensors	41
12.2	Accessories	42
13	Index	43

2 List of Figures

Figure 1: Sensor Construction	11
Figure 2: Dimensions Sensor Standard	12
Figure 3: Dimensions Sensor Option unguided	13
Figure 4: Dimensions Sensor Option PNO	13
Figure 5: Dimensions Magnetic Tape	14
Figure 6: Installation with tension weight	17
Figure 7: Installation with dowel and spring	17
Figure 8: Mounting grooves on the sensor	18
Figure 9: Assessment of the pretention of the magnetic tape	19
Figure 10: Correct orientation of the magnetic tape	20
Figure 11: Distance and orientation of the magnetic tape in relation to the sensor	20
Figure 12: Assessment of the guiding rail of the tape in the sensor - twisted magnetic tape	21
Figure 13: Assessment of the guiding rail of the tape in the sensor - skewed mounting of the magnetic tape ...	21
Figure 14: Assessment of the vertical alignment of the sensor	22
Figure 15: LED signals on the upper side of the sensor	24
Figure 16: Protocol CAN standard	25
Figure 17: Protocol DS406	25
Figure 18: Protocol DS417	25
Figure 19: Setting the Heartbeat Cycle Duration	26
Figure 20: Setting the Sending Cycle for the position data	27
Figure 21: Saving the parameters	28
Figure 22: Changing the device into the Operational Mode	28
Figure 23: Changing the device into the Pre-operational Mode	28
Figure 24: Changing the device into the Stopped Mode	29
Figure 25: Changing into the LSS Configuration	29
Figure 26: Saving the parameters in the LSS Mode	29
Figure 27: Setting the baud rate	30
Figure 28: Setting the node-ID	30
Figure 29: Data Protocol SSI Interface	31
Figure 30: Data Protocol Version 2321 / 4221 / 4851	32
Figure 31: Data Protocol Version 2320 / 4220 / 4850	32
Figure 32: Connection to a RS422 Master	35
Figure 33: LIMAX2 Option unguided	35
Figure 34: Address Adjustment and LED Signaling	36
Figure 35: Pin Assignment PROFIBUS	37
Figure 36: Type designation	40

3 List of Tables

Table 1: Configuration of CAN Standard	24
Table 2: Configuration of CANopen DS406	25
Table 3: Configuration of CANopen DS417	25
Table 4: Pin Assignment CAN	26
Table 5: Pin Assignment SSI open cabel ends	31
Table 6: Pin Assignment SSI Interface	31
Table 7: Pin Assignment	32
Table 8: Error-codes of an addressable LIMAX2	34
Table 9: Parameter Adjustment by GSD File	36
Table 10: Parameter PROFIBUS Interface	37
Table 11: Pin Assignment PROFIBUS IN	37
Table 12: Pin Assignment PROFIBUS OUT	37
Table 13: Power Supply	37
Table 14: Control specific Sensors	41
Table 15: Accessories	42

4 General

4.1 Information Operating Manual

This manual contains important information regarding the handling of the device. For your own safety and operational safety, please observe all safety warnings and instructions.

Precondition for safe operation is the compliance with the specified safety and handling instructions. Moreover, the existing local accident prevention regulations and the general safety rules at the site of operation have to be observed.

Please read the operating manual carefully before starting to work with the device! It is part of the product and should be kept close to the device and accessible for the staff at any time. The illustrations in the manual are for better demonstration of the facts. They are not necessarily to scale and can slightly differ from the actual design.

4.2 Explanation of Symbols

Special notes in this manual are characterized by symbols. The notes are introduced by signal words which express the magnitude of danger. Please follow this advice and act carefully in order to avoid accidents and damage and injuries.

Warning notes:

	<p>DANGER! This symbol in connection with the signal word "Danger" indicates an immediate danger for the life and health of persons. Failure to heed these instructions can result in serious damage to health and even fatal injury.</p>
	<p>WARNING! This symbol in connection with the word „Warning“ means a possibly impending danger for the life and health of persons. Failure to heed these instructions can result in serious damage to health and even fatal injury.</p>
	<p>CAUTION! This symbol in connection with the signal word "Caution" indicates a possibly dangerous situation. Failure to heed these instructions can lead to injuries or damage of property.</p>



Special safety instructions:

	<p>DANGER! This symbol in connection with the signal word "Danger" indicates an immediate danger for the life and health of persons due to voltage. Failure to heed these instructions can result in serious damage to health and even fatal injury. The operations may only be carried out by a professional electrician.</p>
--	---

Tips and recommendations:

	<p>NOTE! ... points out useful tips and recommendations as well as information for an efficient and trouble-free operation.</p>
--	--

References:

-  1.2) Marks a reference to chapter 1.2 of this manual.
-  DOC 3.4) Marks a reference to chapter 3.4 of the document DOC.

4.3 Statement of Warranties

The statement of warranties is enclosed separately in the sales documents.

Guarantee

The producer guarantees the functional capability of the process engineering and the selected parameters. The period of warranty is one year and begins with the date of delivery.

4.4 Demounting and Disposal

Unless acceptance and disposal of returned goods are agreed upon, demount the device considering the safety instructions of this manual and dispose it with respect to the environment.

Before demounting:

Disconnect the power supply and secure against re-start. Then disconnect the supply lines physically and discharge remaining energy. Remove operational supplies and other material.

Disposal:

Recycle the decomposed elements:

- Metal components in scrap metal
- Electronic components in electronic scrap
- Recycle plastic components
- Dispose the remaining components according to their material consistence

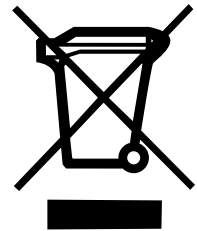

CAUTION!

Wrong disposal causes environmental damages! Electronic scrap, electronic components, lubricants and other auxiliary materials are subject to special refuse and can only be disposed by authorized specialists!

Local authorities and waste management facilities provide information about environmentally sound disposal.

5 Safety



CAUTION!

Please read the operating manual carefully, before using the device! Observe the installation instructions! Only start up the device if you have understood the operating manual.

The operating company is obliged to take appropriate safety measure.
The initial operation may only be performed by qualified and trained staff.

Selection and installation of the devices as well as their embedding into the controlling system require qualified knowledge of the applicable laws and normative requirements on the part of the machine manufacturer.

5.1 General Causes of Risk

This chapter gives an overview of all important safety aspects to guarantee an optimal protection of employees and a safe and trouble-free operation. Non-observance of the instructions mentioned in this operating manual can result in hazardous situations.

5.2 Personal Protective Equipment

Employees have to wear protective clothing during the installation of the device to minimize danger of health.

Therefore:

Change into protective clothing before performing the works and wear them throughout the process. Additionally observe the labels regarding protective clothing in the operating area.

Protective clothing:

	<p>PROTECTIVE CLOTHING ... is close-fitting working clothing with light tear strength, tight sleeves and without distant parts. It serves preliminarily for protection against being gripped by flexible machine parts. Do not wear rings, necklaces or other jewelry.</p>
	<p>PROTECTIVE GLOVES ... for protecting the hands against abrasion, wear and other injury of the skin.</p>
	<p>PROTECTIVE HELMET ... for protection against injuries of the head.</p>

5.3 Conventional Use

The product described in this manual was developed to execute safety-related functions as a part of an entire assembly or machine. It is the responsibility of the manufacturer of a machine or installation to ensure the proper operation of the system. The ELGO-device is conceived only for the intended use described in this manual.

The LIMAX2 - ELGO- length measuring system serves only to measure lengths.



CAUTION!

Danger through non-conventional use! Non-intended use and non-observance of this operating manual can lead to dangerous situations.

Therefore:

- Only use the device as described
- Strictly follow the instructions of this manual

Avoid in particular:

- Remodeling, refitting or changing of the construction or single components with the intention to alter the functionality or scope of the device.

Claims resulting from damages due to non-conventional use are not possible.
Only the operator is liable for damages caused by non-conventional use.

6 Transport and Storage

6.1 Safety Instructions for Transport, Unpacking and Loading

**CAUTION!**

Transport the package (box, palette etc.) professionally. Do not throw, hit or fold it.

6.2 Handling of Packaging Material

Notes for proper disposal: ☞ 4.4

6.3 Inspection of Transport

Check the delivery immediately after the receipt for completeness and transport damage.

In case of externally recognizable transport damages:

- Do not accept the delivery or only accept under reserve.
- Note the extent of damages on the transportation documents or delivery note.
- File complaint immediately.

**NOTE!**

Claim any damage immediately after recognizing it. The claims for damage must be filed in the lawful reclaim periods.

6.4 Storage

Store the device only under the following conditions:

- Do not store outside
- Keep dry and dust-free
- Do not expose to aggressive media
- Protect from direct sun light
- Avoid mechanical shocks
- Storage temperature (☞ 8.6) needs to be observed
- Relative humidity (☞ 8.6) must not be exceeded
- Inspect packages regularly if stored for an extensive period of time (>3 months)

7 Product Features

LIMAX2 is an absolute measuring shaft information system that is used for positioning of elevator cars. It consists of only two components: sensor and magnetic band.

A big advantage of the system is the simple and flexible installation. The assembly of the system components is very simple and can be performed by specialists in less than an hour. The system can be placed anywhere in the shaft, depending of the space conditions. With the small space requirement, LIMAX2 is perfect for retrofitting and modernization.

LIMAX2 detects the absolute car position up to a hoisting height of 260 meters and is designed for speeds of up to 10 m/s. In the standard configuration LIMAX2 evaluates the position with a resolution of 1 mm. Resolutions up to 0.0625 mm are possible.

LIMAX2 is equipped with various interfaces and thus can be directly connected to the most established elevator controls.

The features at a glance:

- Robust measuring principle for usage in rough environments
- Simple and flexible installation
- High accuracy and reproducibility
- No slip
- Absolute position is always directly available - no referencing even after long power outages

7.1 Functional principle

The concept is simple: A sensor mounted on the elevator car detects the current absolute car position using Hall sensors, which read the magnetic tape mounted in the shaft without any contact. Through this method, the car's position can be determined at any time with high accuracy. The guide is only used to keep the tape within a defined distance from the sensor.

Due to its robustness, the magnetic tape technology is ideal for use in elevator systems - dust, dirt, and even dense black smoke won't affect measurement quality. The system even withstands humidity and high temperatures without any problems - making LIMAX2 ideally suited for firefighters' elevators. And that with a long maintenance-free service life.

7.2 Sensor Construction

The sensor consists of the following components:

- Sensor housing with integrated LED line for signaling various states and with permanently connected cable connection for power supply and for communication with the lift controller.
- Guide rail with plastic underlay (keeps the magnetic tape at the defined distance from the sensor).
- Safety splint for mechanical fixing of the polymer guide strip.

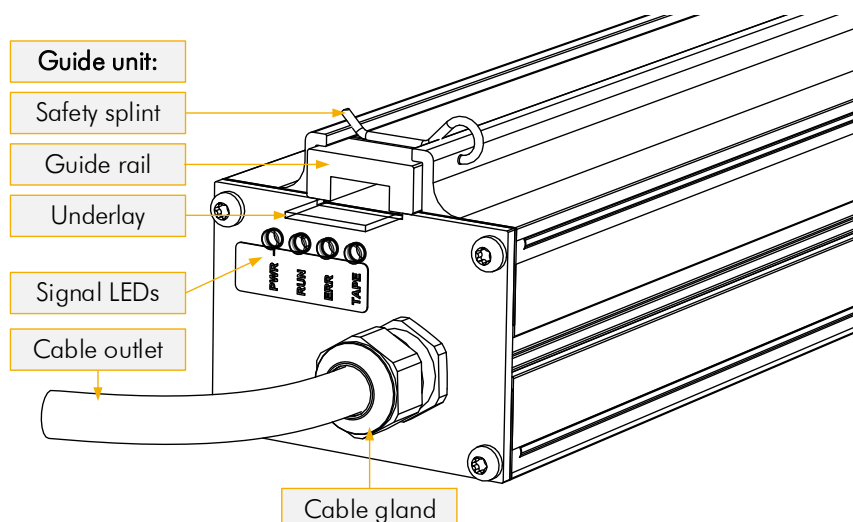

Figure 1: Sensor Construction

8 Technical Data

8.1 Identification

The type label serves for the identification of the unit. It is located on the housing of the sensor and gives the exact type designation (=order reference, see type designation) with the corresponding part number. Furthermore, the type label contains a unique, traceable device number. When corresponding with ELGO always indicate this data.

8.2 Dimensions Sensor Standard

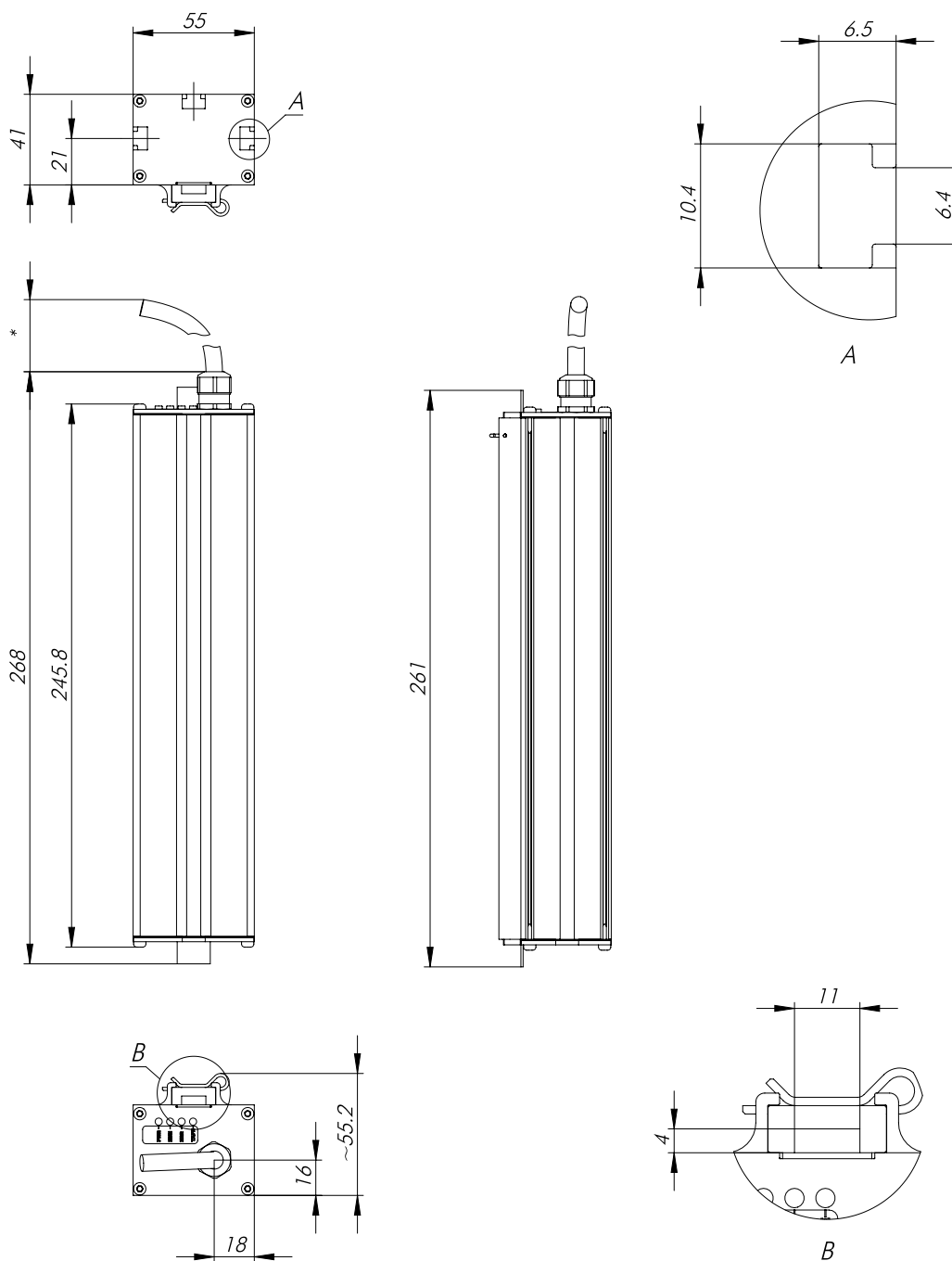

Figure 2: Dimensions Sensor Standard

8.3 Dimensions Sensor Option unguided

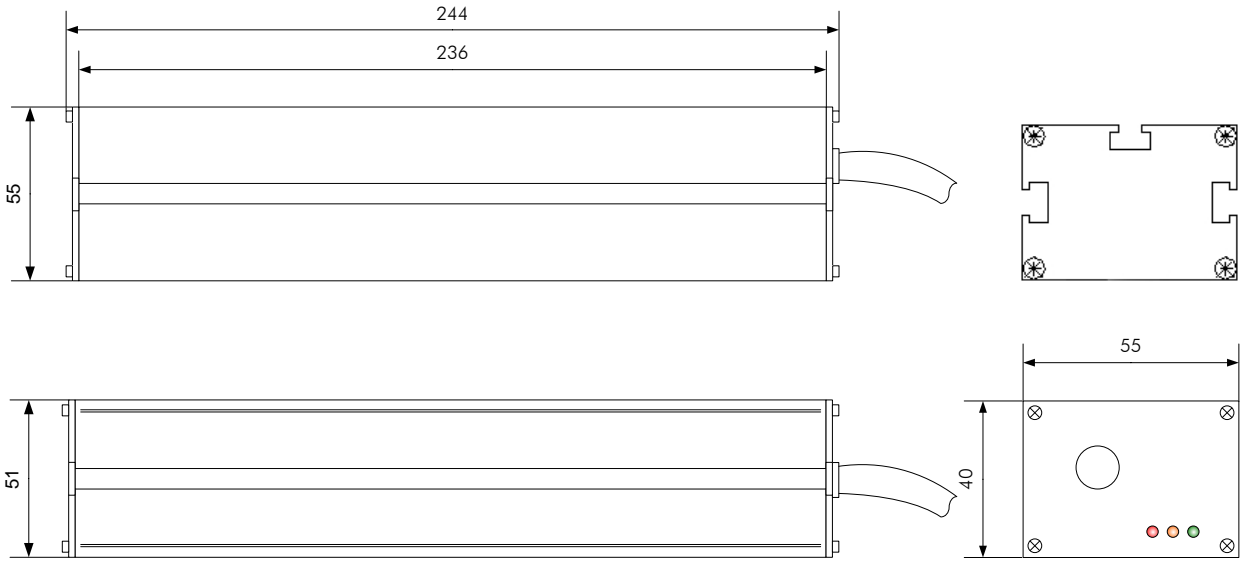

Figure 3: Dimensions Sensor Option unguided

8.4 Dimensions Sensor Option PNO

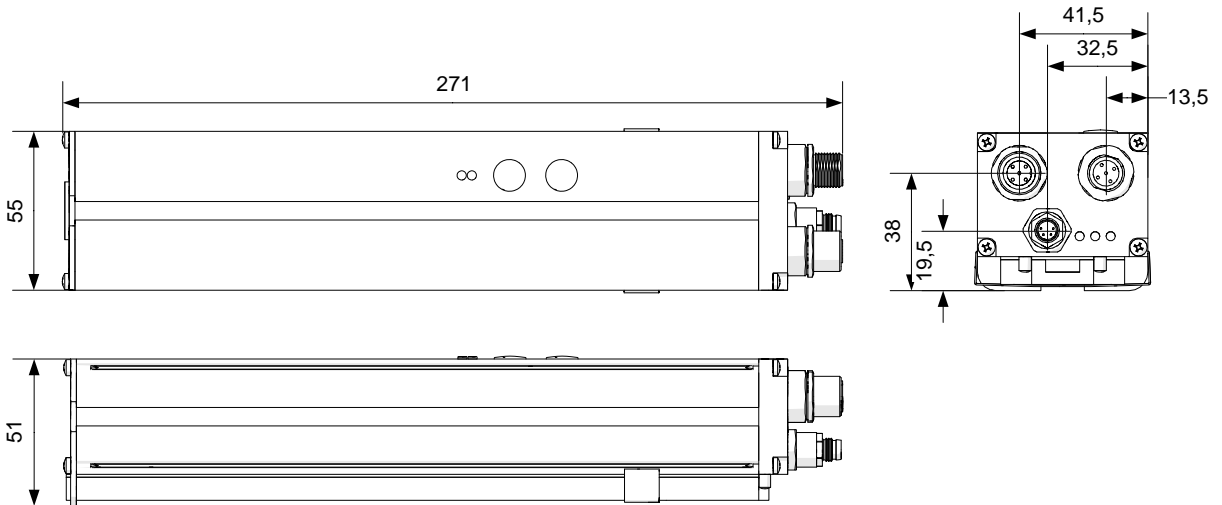

Figure 4: Dimensions Sensor Option PNO

8.5 Dimensions Magnetic Tape

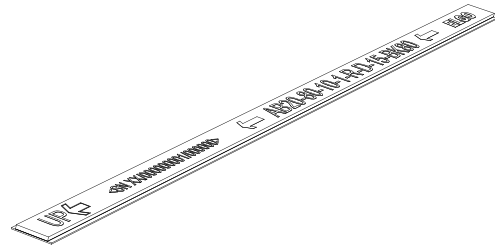
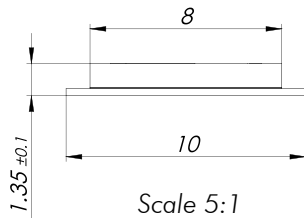

Figure 5: Dimensions Magnetic Tape

8.6 Technical Data Sensor

LIMAX2 (Standard version)

Mechanical Data

Measuring principle	absolute
Repeat accuracy	±1 Increment
System accuracy in μm at 20°C	$\pm(1000 + 50 \times L)$ L = measuring length in meter
Distance sensor - magnetic tape	max. 4 mm
Basic pole pitch	8 mm
Sensor housing material	aluminium
Sensor housing dimensions	L x W x H = 246 x 55 x 55 mm
Necessary type	AB20-80-10-1-R-D-15-BK80
Maximum measuring length	260 m
Connection	Open cable ends (more options ↗ 12)
Sensor cable	3 m standard cable length (other on request)
Weight	approx. 460 g without cable (cable approx. 60 g/m)

Electrical Data

Supply voltage	10 ... 30 VDC
Residual ripple	10 ... 30 VDC < 10%
Power input	max. 200 mA
Interfaces	SSI, CAN, CANopen (DS406, DS417), RS422, RS232, RS485, PROFIBUS
Resolution	According to the Type Designation (↗ 12)
Speed	max. 10 m/s (higher speeds on request)

Conditions

Storage temperature	-20 ... +85° C
Operation temperature	-10 ... +70° C (-25 ... +85° C on request)
Humidity	max. 95 %, not condensing
Protection class	IP50 (IP54 on request)

8.7 Technical Data Magnetic Tape

The magnetic tape consists of two components:

- The actual magnetic tape which carries the position information
- A mechanical stainless steel back iron

TEMPLATE Magnetic Tape AB20-80-10-1-R-D-15-BK80







Coding	absolute, single track system
Pole pitch	8 mm
Operation temperature installed	-20 ... +65° C (-20 ... +80° C when using without adhesive tape, options „B“ or „D“)
Storage temperature uninstalled	Short-term: -10 ... +60° C Medium-term: 0 ... +40° C Long-term: +18° C (-20 ... +80° C when using without adhesive tape, options „B“ or „D“)
Gluing temperature:	+18 ... +30° C
Relative humidity	max. 95 %, non-condensing
Accurateness 20°C in µm	±(1000 + 50 x L) (L = measuring length in meters)
Material carrier tape	Precision strip 1.4310 / X10CrNi 18-8 (EN 10088-3)
Double-faced adhesive tape	3M-9088 (observe instructions), others on request
Dimensions	→ without adhesive tape: 10 mm (±0.1) x 1,35 mm (±0.11) → with adhesive tape (excl. carrier): 10 mm (±0.1) x 1,56 mm (±0.13) → with adhesive tape (incl. carrier): 10 mm (±0.1) x 1,63 mm (±0.14)
Length expansion coefficient	$\alpha \approx 16 \times 10^{-6} \text{ 1/K}$
Thermal length expansion	$\Delta L[\text{m}] = L[\text{m}] \times \alpha[1/\text{K}] \times \Delta \vartheta[\text{K}]$ (L = tape length in meters, $\Delta \vartheta$ = relative temperature change)
Bending radius	min. 150 mm
Available lengths	up to 260 m
Weight magnetic tape	ca. 62 g/m (incl. magnetic tape and cover tape)
Tape imprint	ELGO standard, printing color black, digit height ≥ 5 mm
Influence of external magnets	External magnetic fields must not exceed 64 mT (640 Oe; 52 kA/m) on the surface of the magnetic tape as this could damage or destroy the code on the tape.
Protection class	IP65

9 Installation and First Start-Up

	<p>CAUTION</p> <p>Please read the operating manual carefully before using the device! Strictly observe the Installation instructions!</p> <p>In case of damage caused by failure to observe this operating manual, the warranty expires.</p> <p>ELGO is not liable for any secondary damage and for damage to persons, property or assets.</p> <p>The operator is obliged to take appropriate safety measures. The first start-up may only be performed by staff that has been trained and authorized by the operator.</p>
---	---

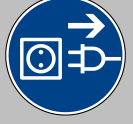
9.1 Operating Area

	<p>WARNING!</p> <p>Do not use the device in explosive or corrosive environments!</p> <p>The device must not be installed close to sources of strong inductive or capacitive interference or strong electrostatic fields!</p>
---	---

	<p>CAUTION!</p> <p>The electrical connections must be made by suitably qualified personnel in accordance with local regulations.</p>
	<p>The device may be designed for switchboard mounting. During work on the switchboard, all components must be de-energized if there is a danger of touching the energized parts! (protection against contacts)</p>
	<p>Wiring works may only be performed in the de-energized state!</p>
	<p>Thin cable strands have to be equipped with end sleeves!</p>
	<p>Before switching on the device, connections and plug connectors have to be checked!</p>
	<p>The device must be mounted in a way that it is protected against harmful environmental influences such as splashing water, solvents, vibration, shock and severe pollution and the operating temperature must not be exceeded.</p>

9.2 Description installation of the Sensor

9.2.1 Installation Principle

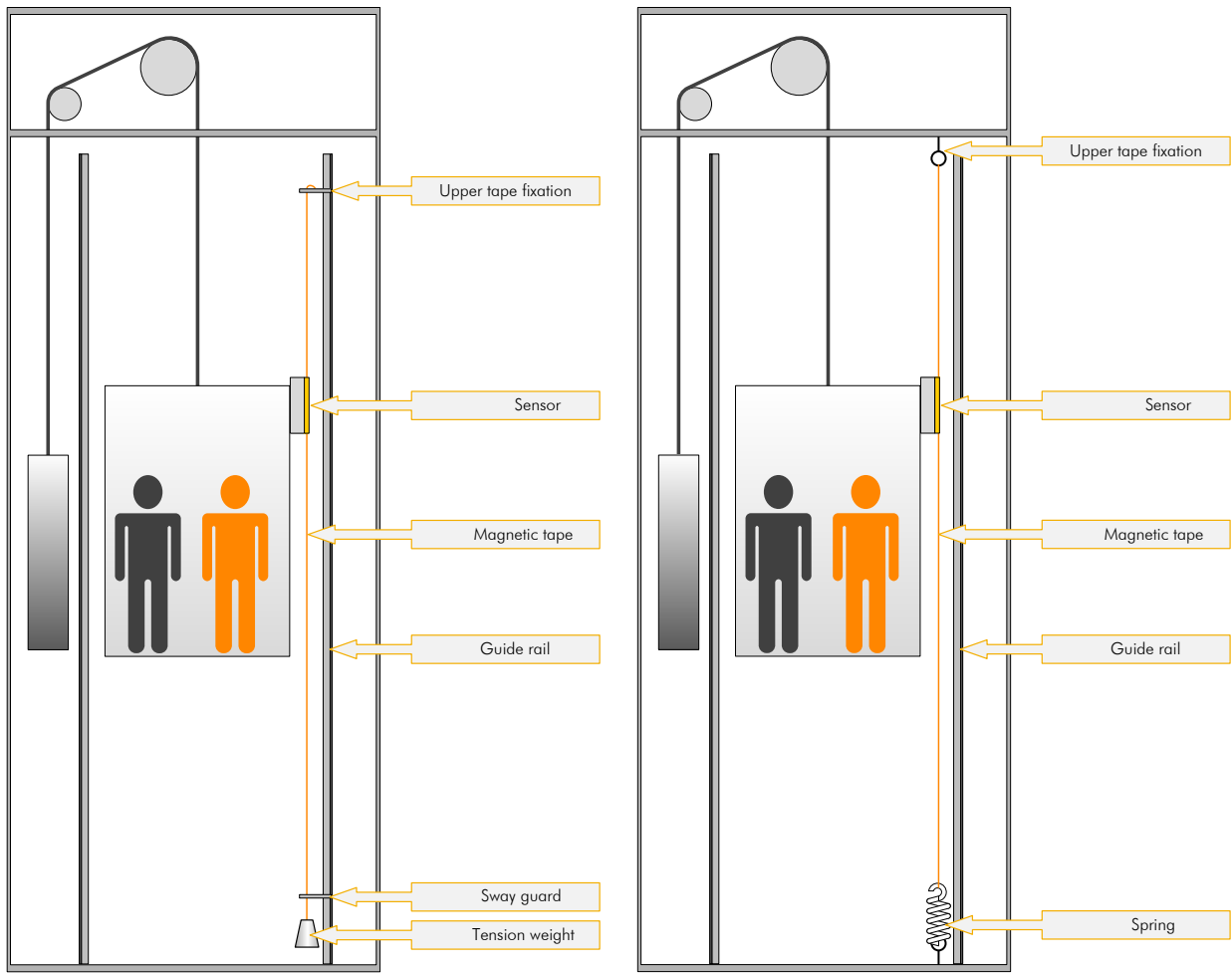

Figure 6: Installation with tension weight

Figure 7: Installation with dowel and spring

LIMAX2 can be installed at any position in the shaft, depending on spatial conditions and layout of the particular elevator installation.

The magnetic tape is installed freely suspended in the shaft. It can be fixed with the RMS mounting kit (available as option) on the guide rail. Alternatively fixation in the shaft head is either on beams or directly bolted into the ceiling. The necessary tension in the tape is provided by a tension weight of about 5 kg. A sway guard at the bottom will keep the tape from swaying in an uncontrolled position. Alternatively the magnetic tape can be tensioned by a spring.

The sensor head can be mounted onto the cabin or cabin frame, depending on the spatial conditions of the elevator.

9.2.2 Installation of the Sensor

The sensor is fixated on the cabin or on the car frame. The mounting position is basically determined by the condition.

The integrated mounting notches on the housing of the sensor head allow for a very simple and self-explanatory installation from three sides. You can either use M6 hexagon head screws (DIN 933) or M6 square nuts (DIN 562), to mount the system at the desired position.

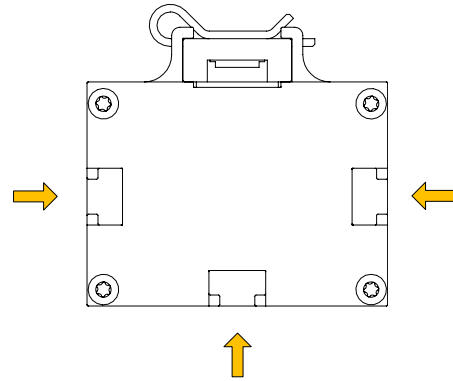



Figure 8: Mounting grooves on the sensor

	<p>NOTE During installation of the magnetic tape in the sensor, pay attention to the marks on the magnetic tape and on the sensor head.</p> <p>Wrong orientation of tape vs. Sensor head will yield incorrect position readings! The arrows printed on the magnetic tape and sensor head point in positive counting direction (in the direction of the shaft head)!</p>
--	---

9.3 Description installation / Mounting of the Magnetic Tape

	<p>NOTE External Magnetic Fields The magnetic tape must not be influenced by external magnetic fields! The magnetic tape must not come into direct contact with other magnetic fields (e.g. permanent magnets, magnetic clamps, electromagnets, magnetic stands)! This may cause irreparable damage, which will compromise the measuring accuracy or even the functioning.</p>
---	---

9.3.1 General Information

The technology has proven to be highly robust. LIMAX2 will work under the most adverse environmental conditions. Extreme temperatures, high moisture and excessive soiling will not alter the information coded onto the tape nor will these conditions affect reading precision of the sensor. Even weak magnetic fields such as they are generated by door magnets can be tolerated.

If some basic rules and guidelines are followed LIMAX2 systems require a minimum amount of installation and maintenance effort while offering maximum lifetime.

One important issue to consider is the protection of the magnet tape against mechanical wear. The LIMAX2 tape consists of two components:

- The magnetic tape which actually carries the position information
- A protective steel tape which gives the mechanical properties

9.3.2 Installation Concept

9.3.2.1 Basic Principle for the Mounting



NOTE!

The magnetic tape itself is not designed to withstand excessive mechanical wear. It is therefore important to ensure that the system is installed such that the mechanical contact between tape and sensor head is mainly between the steel tape and the polymer sensor guide. These two materials have been specifically paired for this application.

Avoiding contact between the magnetic side and the sensor could be achieved with a perfectly perpendicular installation of the band. Yet, in reality this is not practicable. It is therefore preferable to install the tape with a horizontal offset from the sensor. During operation this method will result in a forced contact between the steel side of the band and the polymer guide of the sensor which guarantees an optimal operation of the system.

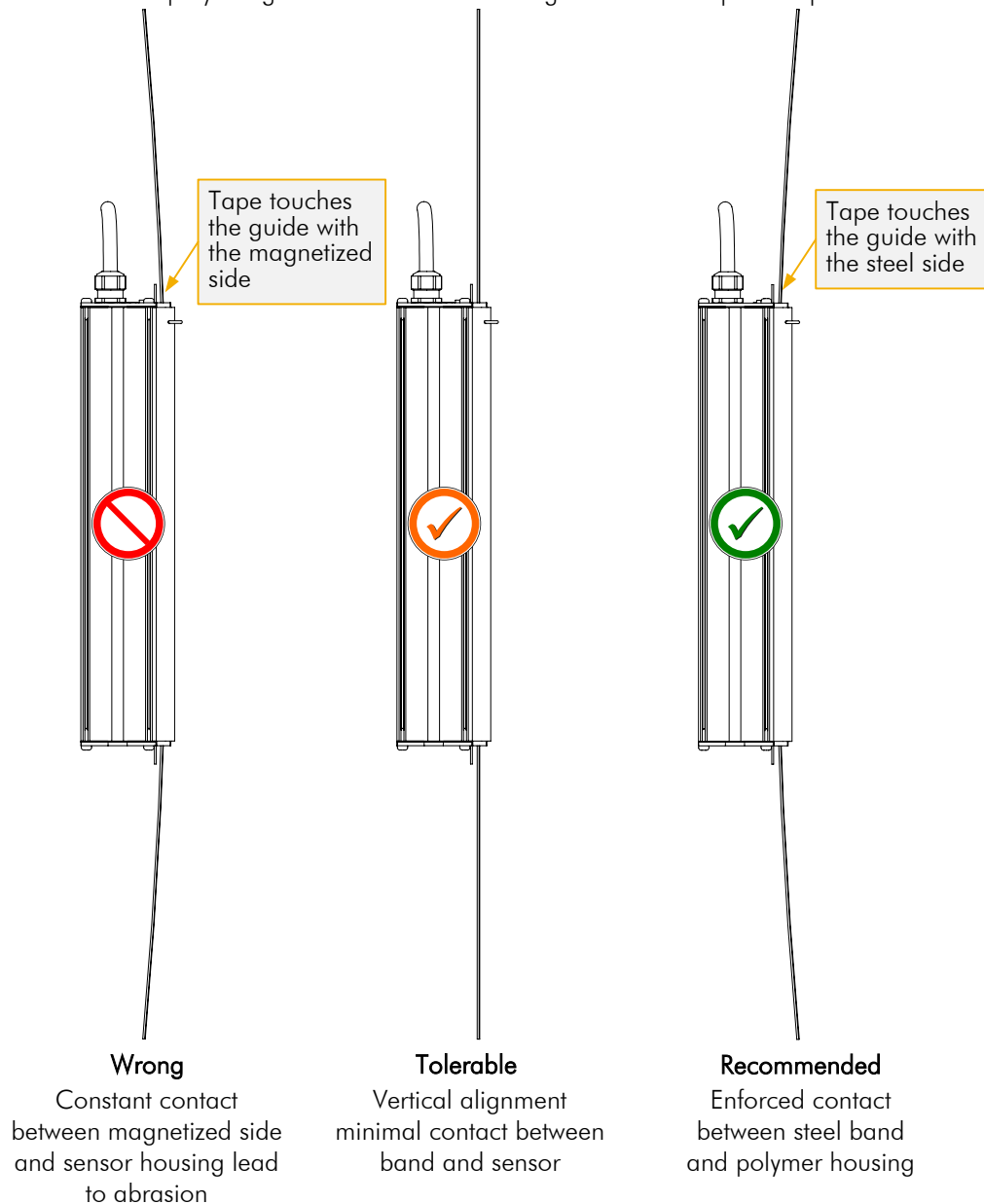

Figure 9: Assessment of the pretention of the magnetic tape

9.3.3 Installation Procedure

1. Attach the top end of the tape in the shaft head. Ideally use an ELGO Mounting Kit. Check for correct orientation of the tape. The arrows on the magnetic side must point in upward direction.



Figure 10: Correct orientation of the magnetic tape

2. The magnetic side of the tape must face the sensor body. In most situations this means that the steel side points to the shaft wall.
3. Drive down the shaft with inspection speed and unroll the tape. The ELGO tape packaging system has been specifically designed for this purpose. The tape can be unwound directly from the box without opening.
4. Attach the tension weight (about 7.5 kg) at the bottom end of the tape in the shaft. Secure the tape with a sway guard. Pay attention to a proper vertical mounting of the tape. If you use dowels to fix the tape in the shaft, tighten the spring such, that the according tractions results to minimum 7.5 kg. When using the ELGO Mounting Kit RMS/RMS90 this is equivalent to a spring elongation of about 90 mm. Note that slightly higher tensile forces are never a problem, but avoid under-tensioning. In higher buildings it may even be preferable to slightly increase the tension in order to prevent flapping of the tape during operation. However, if correctly installed tensile forces of more than 10 kg should never be necessary.
5. Drive the car to the middle of the shaft.
6. Attach the sensor to the car. The side with the cable outlet and the LED's must face upward.
7. Adjust the sensor using the tape as a reference. First, align sensor and magnet band on their centerline.

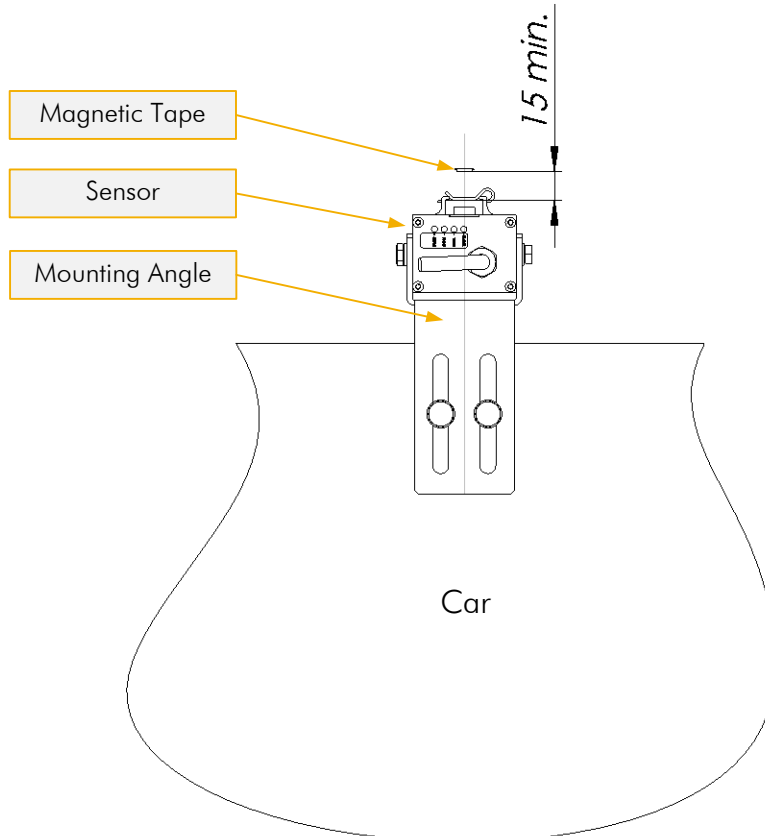

Figure 11: Distance and orientation of the magnetic tape in relation to the sensor

8. Adjust now the distance between sensor and tape. Up to a travel height of 50 m we recommend an offset of at least 15 mm. This will ensure steady contact between steel side of the band and the polymer guide of the sensor. This level can be increased later, if it turns out that the band still rubbing with the magnetic side on the sensor.
In higher installations this distance may be increased by the initial assembly up to 5 cm.
Pay attention to a perpendicular alignment of the sensor. Misalignment will lead to increased wear.
9. Pass the tape through the sensor. Loosen the splint-pin and release the polymer guide. Insert the tape and re-attach the guide with the tape in its position.
10. Pay attention that the pad does not slip after removal of the polymer guide from the aluminum guide out and drops down in the shaft.
11. Check for proper alignment of band vs. sensor. Any angular offset should be corrected.

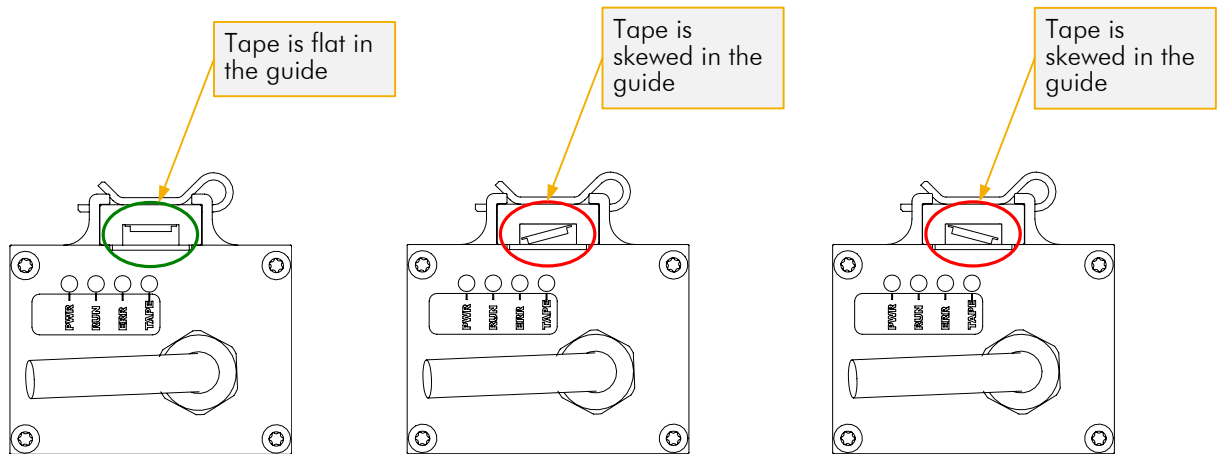

Figure 12: Assessment of the guiding rail of the tape in the sensor - twisted magnetic tape

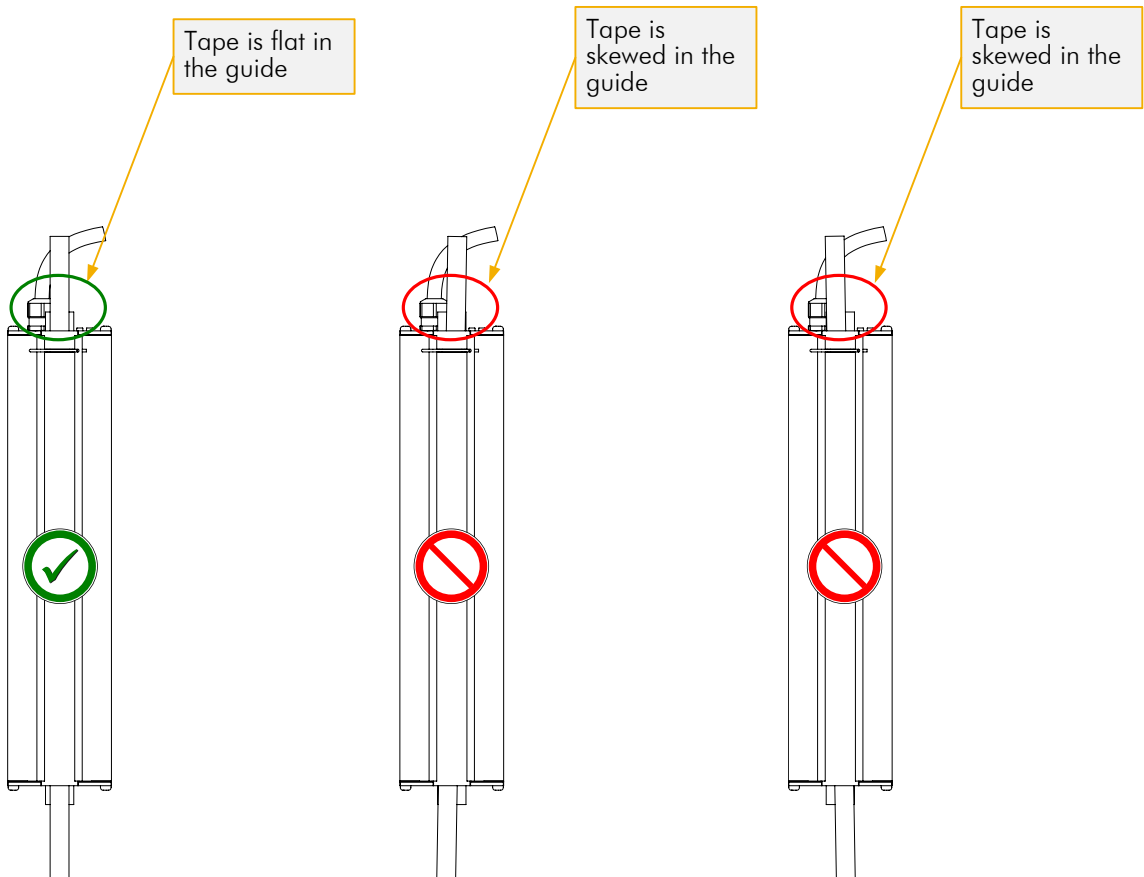

Figure 13: Assessment of the guiding rail of the tape in the sensor - skewed mounting of the magnetic tape

12. IMPORTANT: Installation check!

Values for tape tension and offset between tape and sensor are guidelines based on experience. But in any case, a proper check after installation is mandatory. **It must absolutely be avoided that the magnetic side constantly grinds on the sensor body during operation.** Run an inspection trip along the complete shaft. Observe the system and pay attention to the respective positions of band and sensor. You have achieved an optimal installation if the steel side of the tape is constantly pressed slightly against the polymer guide of the sensor. At some points in the shaft also double-check on the bottom side of the sensor. If the sensor is tilted it may look good on top but the tape can still grind along the bottom edge of the sensor.

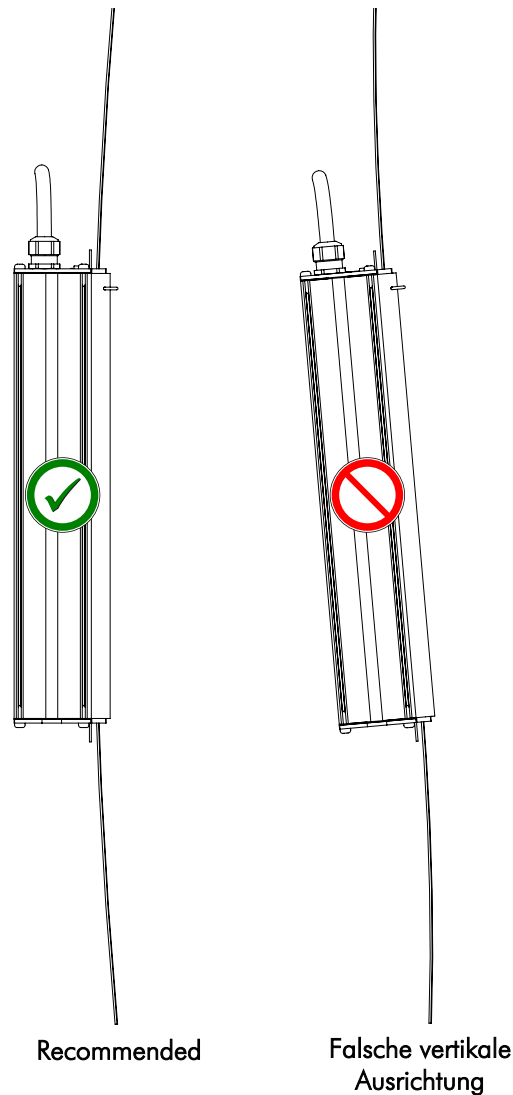





Figure 14: Assessment of the vertical alignment of the sensor

13. If the installation-check reveals that the tape slides on magnetic side, start to increase the offset between sensor and tape. Values of up to 5 cm are acceptable. If this measure does not solve the problem it is very likely that the tape is not plumb in the shaft. This is easy to check for, provided your elevator control allows for inspection trips without the absolute position signal: Just take the tape out of the sensor and run an inspection trip along the shaft. Observe the distance between sensor and tape along the travel. Misalignments will become obvious. Also ensure that the tension on the tape is sufficient. A loosely tensioned tape will hinder proper guiding.
14. After completion of the installation clean the tape. Beginning at the top of the shaft drive down the complete travel distance pulling the magnet tape through a dry clean cloth.

Please observe and follow the instructions in the note boxes on the next page!

	<p>NOTE!</p> <p>Be specifically alert if steel construction work is taking place in the shaft. Steel particles released by grinding, welding or such work will adhere to the magnetic tape. The tape is insensitive to fine metal dust. However, <u>coarser</u> metal chips can cause problems. Clean this debris off instantly. Repeat the cleaning process before putting the elevator into operation after complete installation.</p>
	<p>DO NOT USE A MAGNET FOR CLEANING!</p> <p><u>Never</u> use a magnet to remove metal chips from the magnetic tape. This will destroy the magnetic code and thus the magnetic tape.</p>
	<p>PROTECTIVE GLOVES!</p> <p>Always wear protective gloves when cleaning the magnetic tape.</p>

10 Connections and Interfaces

10.1 LED's (Operating status and notices)

The LED's located on the front serve for monitoring of operating conditions.

With startup it has to be ensured that the yellow LED illuminates as this monitors the internal supply voltage.

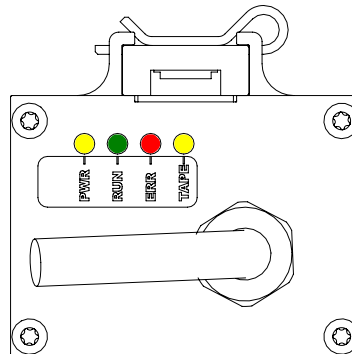

Figure 15: LED signals on the upper side of the sensor

- **PWR YELLOW** → Supply voltage

ON = Supply voltage OK

OFF = Supply voltage not provided

- **RUN GREEN**

for CANopen device: RUN-LED according to DR 303-3

other device: Interface state, flashes during active communication

- **ERR RED**

for CANopen device: ERR-LED according to DR303-3

other device: Error message

ON = State error, system not operational

OFF = State OK, system ready for operation

- **TAPE YELLOW** → Indicator for magnet tape

ON = Magnet tape missing

OFF = Magnet tape available

10.2 CAN Interface

10.2.1 CAN Standard

Table 1: Configuration of CAN Standard

CAN Standard	
Bitrate	250 kbit/s
Resolution	1.0 mm
Identifier	184 (hex)
First 4 Bytes	Position in mm
Next 2 Bytes	Speed in mm/s

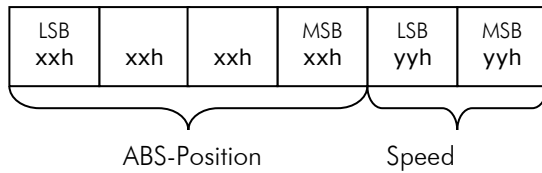

Figure 16: Protocol CAN standard

10.2.2 CANopen DS 406 and DS417

For LIMAX2 the CANopen Interfaces DS406 (encoder profile) und DS417 (lift profile) are available. These interfaces are configured by default as follows:

Table 2: Configuration of CANopen DS406

CANopen DS406	
Bit rate	250 kbit/s
Identifier	184 (hex)
Event timer	10 ms
Producer heartbeat	500 ms
Resolution	1.0 mm
First 4 Bytes	Position in mm
Next 2 Bytes	Speed in mm/s

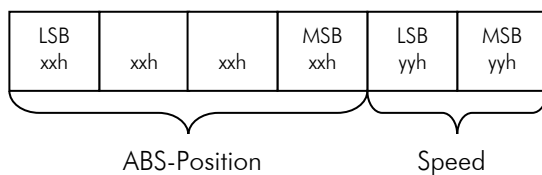

Figure 17: Protocol DS406

Table 3: Configuration of CANopen DS417

CANopen DS417	
Bit rate	250 kbit/s
Identifier	18 C (hex) [Node ID 0x04]
Event timer	0 (switched off)
Producer heartbeat	500 ms
Resolution	0.5 mm

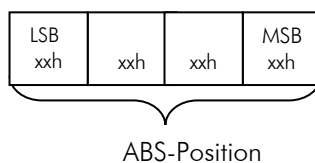

Figure 18: Protocol DS417

10.2.3 Pin Assignment CAN

Table 4: Pin Assignment CAN

9-pin D-SUB connector		Open cable exit	
PIN-No.	Function	Color	Function
Pin 6	0 V / GND	White	0 V / GND
Pin 9	+ 24 VDC	Brown	+ 24 VDC
Pin 2	CAN L	Green	CAN L
Pin 7	CAN H	Yellow	CAN H
Pin 3	CAN GND	Blue	CAN GND
Housing*	PE	Shield*	PE

*) please connect shield only at control unit side!

10.2.4 Command Descriptions

10.2.4.1 Initial Operation

After starting the CANopen device is in the Pre-operational Mode (☞ 10.2.6.2) and therefore doesn't send any position data. In order to achieve this, the device needs to be set into Operational Mode (☞ 10.2.6.1) and if necessary the sending cycle of the position data has to be adjusted (☞ 10.2.4.4).

10.2.4.2 Normal Mode

i

Note!
The commands which are described in section 10.2.4.2 Normal Mode are only processed by the CANopen device in the Operational and Pre-Operational mode.

10.2.4.3 Setting the Heartbeat Cycle Duration

A CANopen device sends the heartbeat cyclically. This message communicates the current Operating Mode to the other bus sharing units.

1. Change into the Operational or Pre-operational Mode, if necessary
2. The following illustration shows the CAN-message, which should be transmitted to the CANopen device and the following answer.

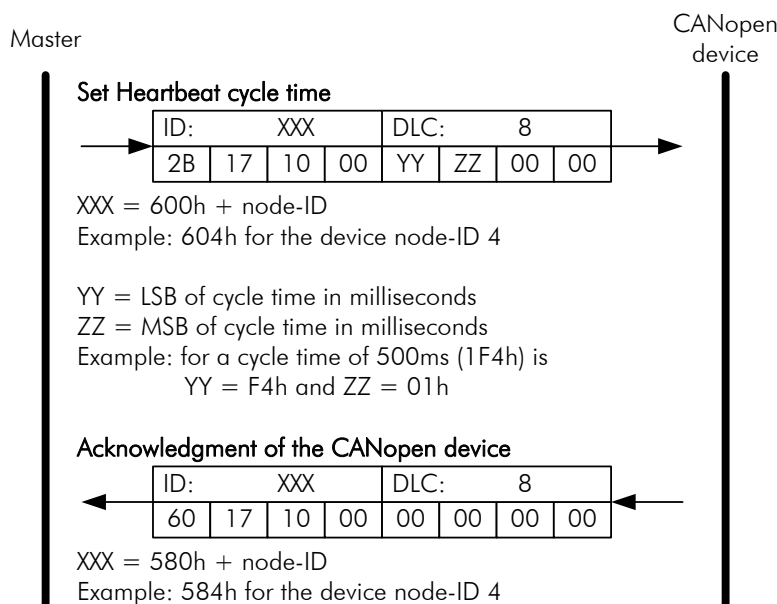

Figure 19: Setting the Heartbeat Cycle Duration

3. If the setting should be maintained in the case of a power failure, the changes have to be saved, as described in section (☞ 10.2.5).

10.2.4.4 Setting the Sending Cycle for the Position Data

The position data are sent cyclically by the device, therefore the device has to be in the Operational Mode (☞ 10.2.6.1).

The settings of the cycle duration takes place in the device profile DS406 in the object 1800h, Sub-index 5 and for devices with DS417 profile in object 1906h, Sub-index 5.

1. Change into the Operational or Pre-operational Mode, if necessary.
2. The following figure shows the CAN-message, which should be transmitted to the CANopen device and the following answer.

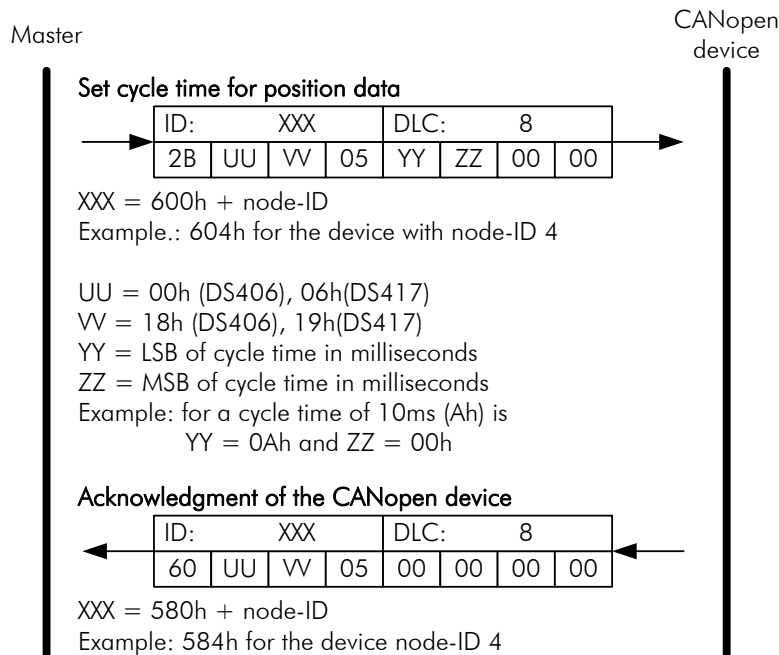

Figure 20: Setting the Sending Cycle for the position data

3. If the settings should be maintained in case of a power failure, the changes have to be saved, as described in section (☞ 10.2.5).

10.2.5 Saving the Parameters

In the normal case the settings are lost at power failure. In order to avoid this, they need to be saved according to the following procedure.

1. Change into the Operational or Pre-operational Mode, if necessary.
2. The following figure shows the CAN-message, which should be transmitted to the CANopen device and the following answer:

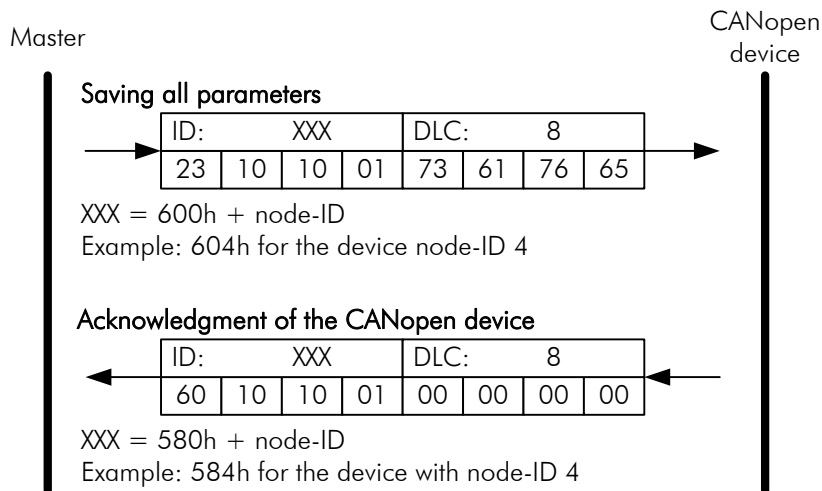

Figure 21: Saving the parameters

10.2.6 Changing the Operating Modes

10.2.6.1 Changing the device into the Operational Mode

In the Operational Mode the communication of the device is fully functional.

The following CAN-message causes the change of all CANopen participants into the Operational Mode.

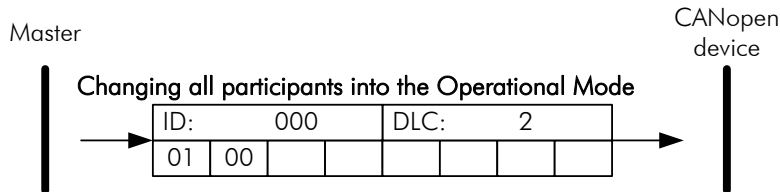

Figure 22: Changing the device into the Operational Mode

10.2.6.2 Changing the device into the Pre-operational Mode

In the Pre-operational Mode the communicating settings of the device are adjusted.

The following CAN-message causes the change of all CANopen participants into the Pre-Operational mode.

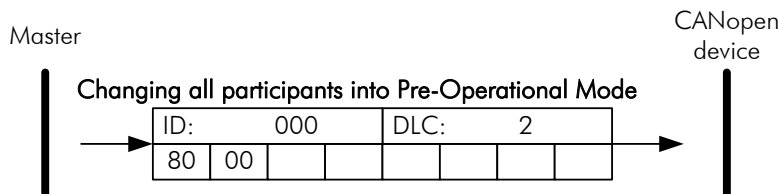

Figure 23: Changing the device into the Pre-operational Mode

10.2.6.3 Changing the device into the Stopped Mode

Bus sharing units in the Stopped Mode are passive participants. In this mode all the communication is turned off, except the monitoring activity (e.g. heartbeat).

The following CAN-message causes the change of all CANopen participants into the Stopped Mode:

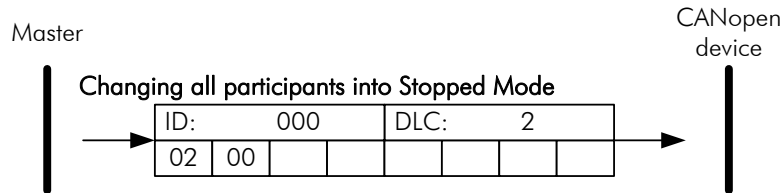



Figure 24: Changing the device into the Stopped Mode

10.2.7 LSS Configuration

Basic settings like node-ID and baud rate have to be adjusted with the Layer Setting Services (LSS).

10.2.7.1 Changing into the LSS Configuration Mode

In order to be able to change the Parameter (node-ID, bit rate), the device has to be changed into the LSS Configuration Mode.



ATTENTION!

With the following command all the bus sharing units which are in the Stopped Mode are changed into the LSS Configuration Mode. Use this command, if only one device is connected to the bus, because other devices could be affected in their function.

The following CAN-message causes the change into the LSS Configuration Mode.

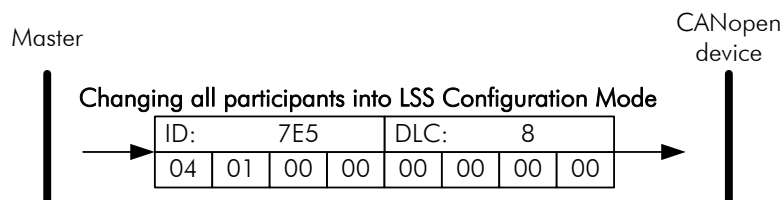

Figure 25: Changing into the LSS Configuration

10.2.7.2 Saving the Parameters in the LSS Mode

In order not to lose the changes in case of a power failure, they have to be saved in the non-volatile memory of the CANopen device.

The following figure shows the necessary message for this procedure.

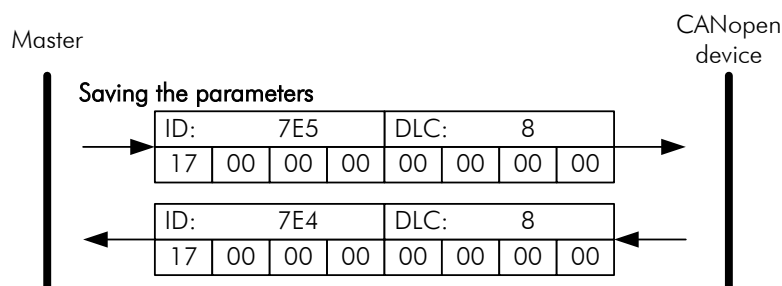

Figure 26: Saving the parameters in the LSS Mode



ATTENTION!

During the saving procedure the device is not accessible over a period of a few milliseconds.

10.2.8 Setting the Baud Rate

1. Change the device into the Stopped mode (☞ 10.2.6.3)
2. Change the device into the LSS Configuration Mode (☞ 10.2.7.1)
3. Change baud rate according to the following command:

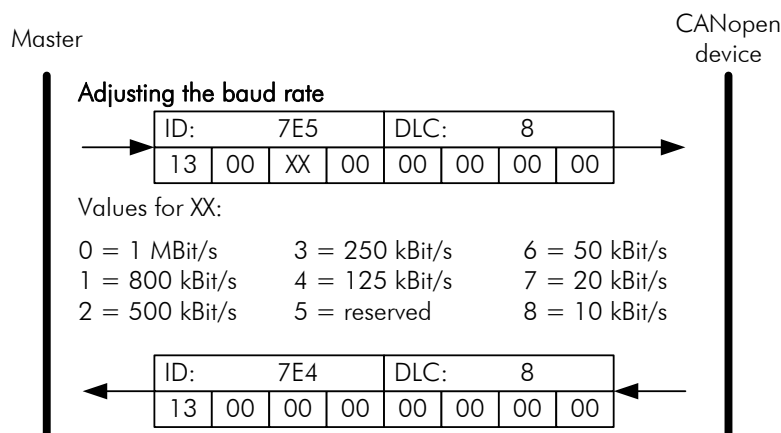

Figure 27: Setting the baud rate

4. Save parameter as described in section (☞ 10.2.7.2).
5. Turn the device off and restart it again.

10.2.9 Setting the node-ID

1. Change the device into the Stopped Mode (☞ 10.2.6.3)
2. Change the device into the LSS Configuration Mode (☞ 10.2.7.1)
3. Change node-ID with the following message:

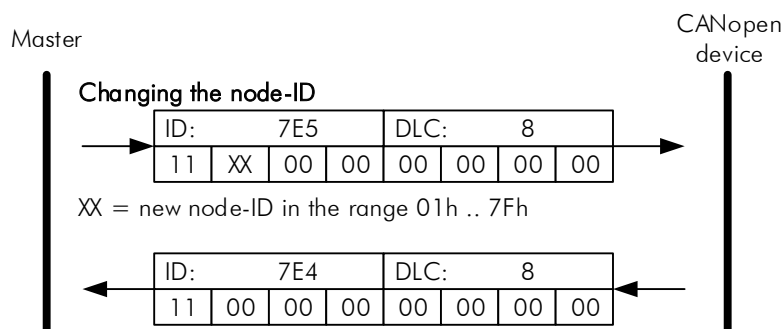

Figure 28: Setting the node-ID

4. Save parameter as described in section (☞ 10.2.7.2).
5. Turn the device off and restart it again.

10.3 SSI Interface

10.3.1 Function Principle

If the clock is not interrupted for the time $T_m - T/2$ (output of further 25 periods), the shift register clocks once again the same data value (error recognition in the evaluation). Some encoders contain a Power Failure Bit (PFB). Attention: With the LIMAX2 the PFB is always "LOW"!

10.3.2 Data Protocol

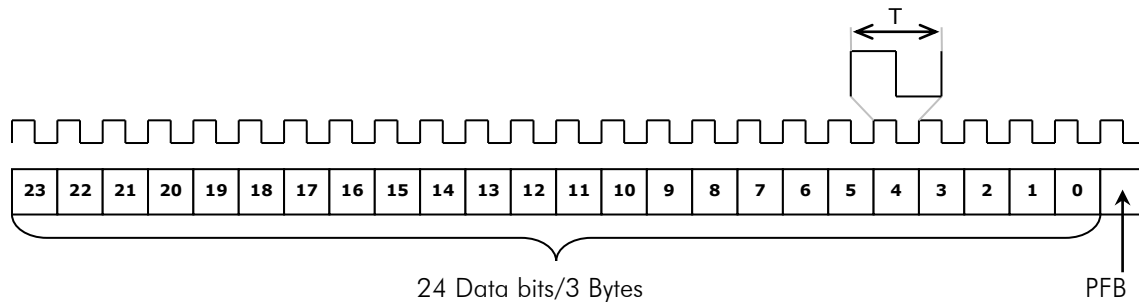

PFB = Power Failure Bit
 T = length of clock signal
 T_m = monostable multivibrator time $> 10\mu s$

Figure 29: Data Protocol SSI Interface

10.3.3 Pin Assignment

Table 5: Pin Assignment SSI open cable ends

Open cable ends	
Color	Function
White	0 V / GND
Brown	+ 24 VDC
Pink	Data -
Grey	Data +
Yellow	CLK -
Green	CLK +
Shield	PE

Table 6: Pin Assignment SSI Interface

9-pin. D-SUB Connector	NEWLIFT FST1 (D9M0)	NEWLIFT FST2 (D9M1)
Pin	Function	Function
1	DATA +	0V / GND
2	CLK -	CLK +
3	-	N.C.
4	24 VDC	DATA +
5	0V / GND	0V / GND
6	DATA -	+ 24 VDC
7	CLK +	CLK -
8	-	DATA -
Housing	PE	N.C.

10.4 RS232 / RS422 / RS485*

*) Attention: RS485 only unidirectional

If the measuring system is equipped with an RS232, RS485 or RS422 interface, the data communication has the following format:

19200 baud (other baud rates on request)
 1 Start bit
 8 data bits
 1 stop bit
 no parity

10.4.1 Data Protocol

The measured absolute position will be represented in the three ABS-position data bytes.

Version 2321 / 4221 / 4851

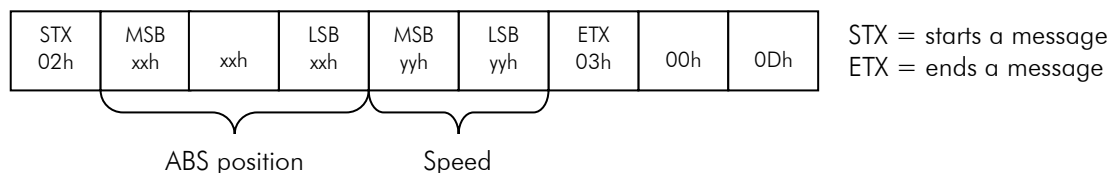

Figure 30: Data Protocol Version 2321 / 4221 / 4851

Version 2320 / 4220 / 4850

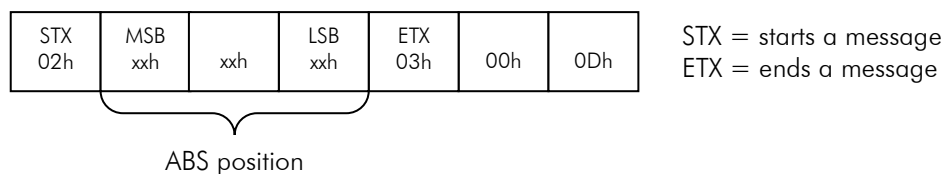

Figure 31: Data Protocol Version 2320 / 4220 / 4850

10.4.2 Pin Assignment

Table 7: Pin Assignment

Open cable ends (Standard)						
Color	RS232		RS422		RS485	
White	0 V / GND		0 V / GND		0 V / GND	
Brown	+ 24 VDC		+ 24 VDC		+ 24 VDC	
Pink	TX		TX -		TX -	
Grey	RX		TX +		TX +	
Yellow	-		RX -			
Green	-		RX +			
Shield	PE	⏏	PE	⏏	PE	⏏

10.4.3 Command Descriptions

Important:

Before you send a new message to the LIMAX2 wait for the answer first. After allocating a new address the LIMAX2 answers in max. 0.5 seconds. In other cases it even in a few milliseconds. After this time it is not expected to get an answer (transmission error).

10.4.3.1 Principle Format of Message

STX 02h	Byte 1	Byte 2	Byte check	ETX 03h
------------	-----------	-----------	---------------	------------

STX 02h	Byte 1	Byte 2	Byte 3	Byte 4
------------	-----------	-----------	-----------	-----------

STX = starts a message
 ETX = ends a message
 Check Byte = contains the arithmetic checksum of STX, byte 1 and byte 2.
 The meaning of bytes 1 to 4 can be found in the following chapters.

10.4.3.2 Position request of LIMAX2 with the address "i"

STX 02h	04h	i	Byte check	ETX 03h
------------	-----	---	---------------	------------

STX 02h	MSB xxh	xxh	LSB xxh	Adr. i
------------	------------	-----	------------	-----------

04h = characterises the message as position request
 i = address of the LIMAX2 (0Bh – 7Fh) to request
 Position values are always smaller than FFFF00h

} ABS-Position

10.4.3.3 A LIMAX2 address request

Attach in each case only one LIMAX2 e.g. over a RS422/RS232 converter to the serial interface (COM-port) of a PC.

STX 02h	05h	05h	Byte check	ETX 03h
------------	-----	-----	---------------	------------

STX 02h	FFh	FFh	i xxh	ETX 03h
------------	-----	-----	----------	------------

05h = characterizes a message as address request
 i = LIMAX2 address
 FFh FFh does not occur immediately after STX with position inquires as answer!
 In this case (0Bh <= i <= 7Fh) this is the answer of the address request.

10.4.3.4 Allocation of an LIMAX2 address

Attach in each case only one LIMAX2 e.g. over a RS422/RS232 converter to the serial interface (COM-port) of a PC.

STX 02h	06h	i	Byte check	ETX 03h
------------	-----	---	---------------	------------

STX 02h	FFh	FFh	i + 80h	ETX 03h
------------	-----	-----	------------	------------

06h = characterizes a message as address allocation
 i = the new LIMAX2 address. Important: At the answer you get the new address + 80h.

The addresses 80 h – FFh as well as 00 h – 0 Ah are FORBIDDEN. If you try to assign an address smaller than eight, LIMAX2 gives you a "negative answer" and keeps its former address.

10.4.3.5 Error Messages

If one of the described operations failed for some reason LIMAX2 gives an error message with a respective error-code.

Answer from LIMAX2

STX 02h	FFh	FFh	ERR xxh	ETX 03h
------------	-----	-----	------------	------------

ERR = Error-Code (04h – 0Ah) error – codes are listed at the next page.

Table 8: Error-codes of an addressable LIMAX2

Code	Meaning
04h	Wrong sequence of bytes sent to LIMAX2, for example if 4. Byte after STX is no ETX or the Byte after STX is not 0x04, 0x05 or 0x06.
05h	Receiving Error / Interface Error (for example if a message with a wrong baud rate was sent etc.)
06h	Invalid LIMAX2 address: appears after trying to assign an address smaller 0Bh or bigger 7Fh to LIMAX2.
07h	LIMAX2 has lost its address: internal check of X redundantly stored address of LIMAX2 has failed. This message is sent at power up immediately if an error in reading EEPROM is detected or if the internal address error cannot be fixed.
08h	Internal EEPROM storage error.
09h	Error in transmission of position (no tape, tape damaged or distance between tape and sensor head too big).
0Ah	Check-Sum-Error: Check-sum of a message sent to LIMAX2 is wrong.

10.4.3.6 Connection to a RS422 Master

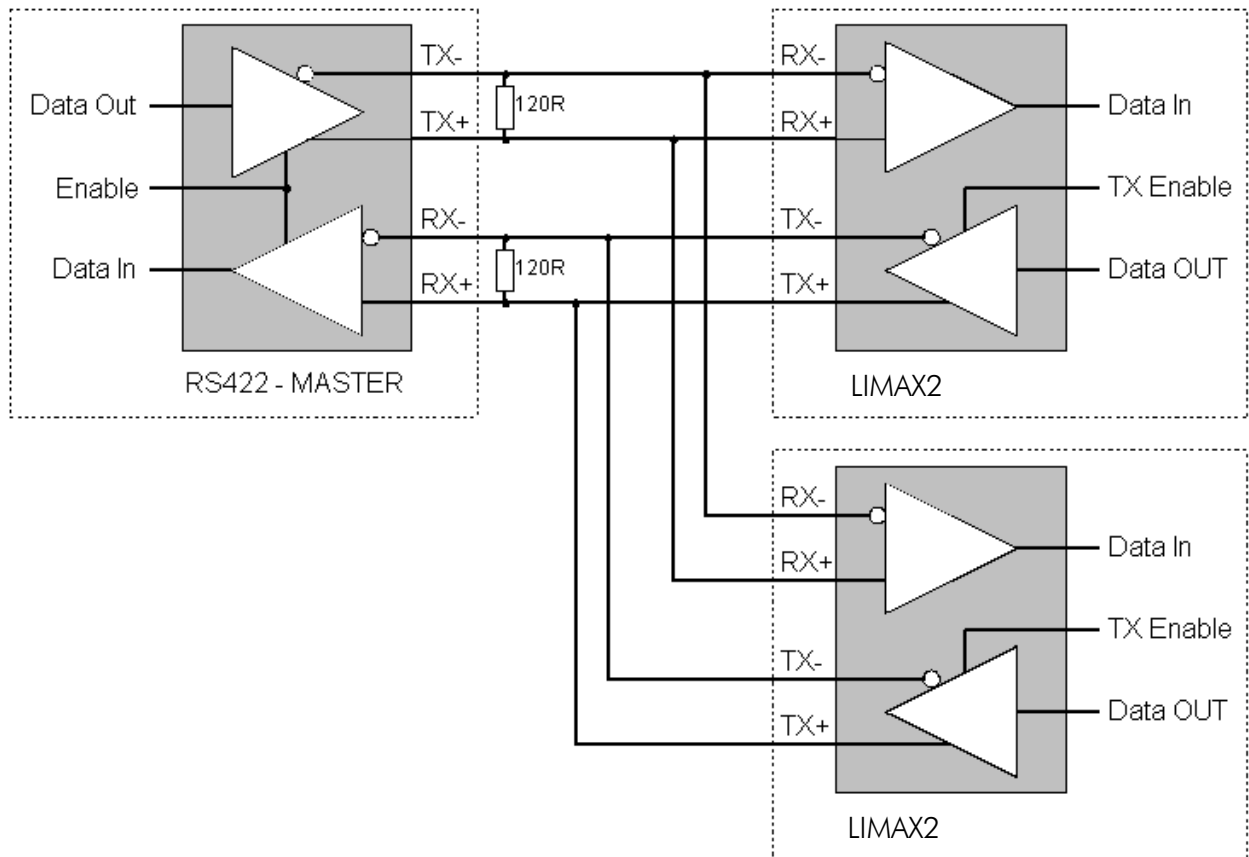

Figure 32: Connection to a RS422 Master

10.5 Option Unguided

LIMAX2 "unguided" is an absolute measuring system, which is used for positioning in the most diverse areas horizontally and vertically. It consists of only two components: magnetic tape and the sensor.



Figure 33: LIMAX2 Option unguided

10.6 Option PROFIBUS Interface

10.6.1 LED's (Operation Status and Messages)

The LED's located on the top side, a green LED (Bus Run) and a red LED (Bus Fail), serve for monitoring of operating status. For setting the address are two rotary coding switches located on the top next to the LED's

- **BUS RUN GREEN**
 - ON = Ready
 - OFF = Supply voltage not provided
 - Flashes cyclic = Slave has no cyclic data exchange with PROFIBUS-DP-MASTER
 - Flashes irregular = start: Missing or faulty configuration
Runtime: Host watchdog- time error

- **BUS FAIL RED**
 - ON = unrecoverable Converter – Fault
 - OFF = no error / bus in cycle
 - Flashing = Converter not addressed by the master

10.6.2 Settings

10.6.2.1 Address Settings

The address settings are done with the coding switches on top of the housing. The higher decade with the coding switch MSD and the low decade with the coding switch LSD.

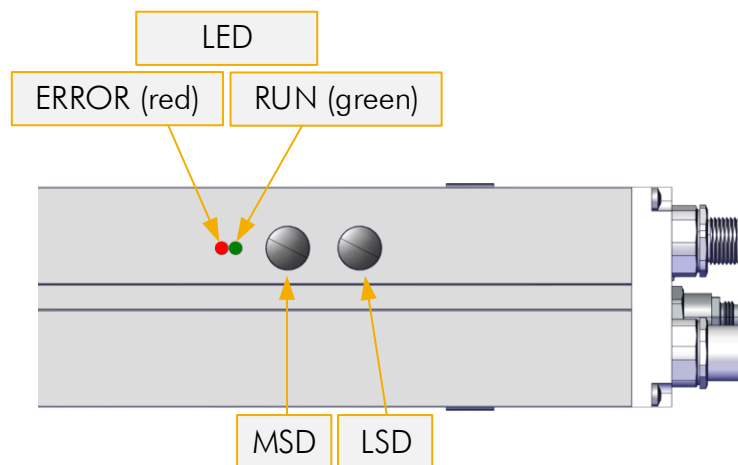

Figure 34: Address Adjustment and LED Signaling

10.6.2.2 Parameter Settings

The following parameters can be configured by GSD File (GSD File is delivered as CD-ROM).

Table 9: Parameter Adjustment by GSD File

Function	Setting Range	Factory Setting
Monoflop	20 ... 255 μ s	[200]
Clock quantity SSI	18 ... 32	[24]
Scale SSI/x	1 ... 255	[1]
Offset	-1073741823 ... 1073741824	[0]

10.6.2.3 PROFIBUS Interface

The sensor option profibus is fitted as standard with a profibus interface according to IEC61158 / IEC61784. The following parameters are specified.

Table 10: Parameter PROFIBUS Interface

PROFIBUS Interface	
Transmission	RS485 two-wire line
Wire length	1200 m at 9,6 kBaud 200 m at 1,5 MBaud 100 m at 12 MBaud
Baud rate	9,6 kBaud to 12 MBaud (auto detect)
Clock rate max.	250 kHz
Participants	max. 32 per Segment (with repeater until 126 expandable) Mono- and Multi-master systems are possible → In delivery status is participant 05 set

10.6.2.4 Pin Assignment

Table 11: Pin Assignment PROFIBUS IN

PROFIBUS IN (Flanged Plug M12)	
Pin	Function
1	N.C.
2	Data A
3	N.C.
4	Data B
5	Shield

Table 12: Pin Assignment PROFIBUS OUT

PROFIBUS OUT (Flanged Socket M12)	
Pin	Function
1	N.C.
2	Data A
3	N.C.
4	Data B
5	Shield

Table 13: Power Supply

Power supply (Fanged Plug M8)		
Pin	Color	Function
1	Brown	+ 10 to 30 VDC
2	White	N.C.
3	Blue	0 V / GND
4	Black	N.C.

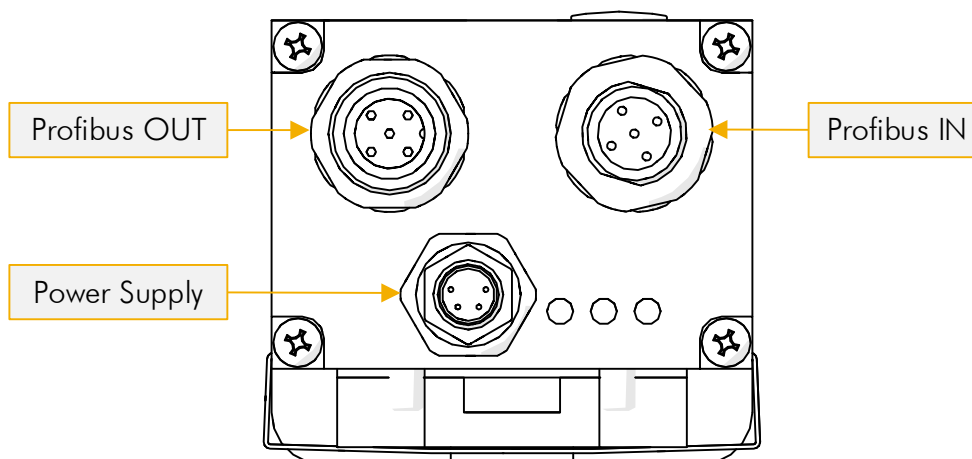

Figure 35: Pin Assignment PROFIBUS

11 Disturbances, Maintenance, Cleaning

This chapter describes possible causes for disturbances and measures for their removal. In case of increased disturbances, please follow the measures for fault clearance in chapter 11.1. In case of disturbances that cannot be eliminated by following the advice and the fault clearance measures given here, please contact the manufacturer (see second page).

11.1 Fault Clearance



CAUTION!

The device, the connection line and the signal cable must not be installed next to sources of interference that emit strong inductive or capacitive interference or strong electrostatic fields.

External perturbations can be avoided through suitable cable routing.



The screen of the signal output cable should only be connected to the following circuit on one side. The screens should not be grounded on both sides. Signal cables always have to be routed separately from the load power line. A safety distance of at least 0,5 m has to be kept from inductive and capacitive sources of interference such as contactors, relays, motors, switching power supplies, clocked controllers etc!

If interferences occur in spite of all the items stated above being observed, please proceed as follows:

1. Installation of RC-circuits via contactor coils of AC-contactors (e.g. 0,1 μ F / 100 Ω)
2. Installation of recovery diodes via DC-inductors
3. Installation of RC-circuits via the different motor phases (in the terminal box of the motor)
4. Do not connect protective earth and ground
5. Connect a mains filter ahead of the external power pack

11.2 Re-start after Fault Clearance

After the fault clearance:

1. Reset the emergency stop mechanism if necessary
2. Reset the error report at the super-ordinate system if necessary.
3. Ensure that there are no persons in the danger area.
4. Follow the instructions from chapter 5.



WARNING!

Danger of injury through non-conventional fault clearance!

Non-conventional fault clearance can lead to severe injuries and damage of property.

Therefore:

- Any work to clear the faults may only be performed by sufficiently qualified staff
- Arrange enough space before starting the works
- Make sure that the mounting area is clean and tidy. Loose components and tools are sources of accidents.

If components need to be replaced:

- Pay attention to a correct installation of the spare parts.
- Reinstall all the fixing elements properly
- Before turning on the device, ensure that all covers and safety equipment is installed correctly and functions properly

11.3 Maintenance

The LIMAX2 shaft information system requires little maintenance. On the occasion of regular elevator inspection and maintenance do the following:

- Optical inspection of proper alignment between sensor and band. Worn off material indicates possible alignment flaws. Check for proper guiding of the band along the complete travel distance. Correct if necessary as described in the installation procedure above.
- Optical inspection of the band. Check for abrasions or other mechanical damages. Small mechanical damages (scratches, dents, or even small chips) do not interfere with the measuring performance at all. However, a pre-damaged band is more exposed to mechanical stress and is prone to further wear.
- Check for proper tension of the band. If the mounting was via a flute, the tension can decrease over time. Readjust if necessary.
- Inspect the polymer guide for wear. Clean if dust and dirt have accumulated between polymer guide and sensor case. The polymer guide is a wear part. Replace if necessary.
- Clean the band. Use a dry and clean cloth. Begin at the head of the hoistway drive down the complete travel distance pulling the magnet band through a dry cloth.

**WARNING!**

Danger through non-conventional maintenance!

Non-conventional maintenance can lead to severe injuries and damage of property.

Therefore:

Maintenance works may only be completed by staff that has been authorized and trained by the operator.

11.4 Cleaning

**WARNING!**

The device can only be cleaned with a damp cloth, do not use aggressive cleanser!

12 Type Designation

	LIMAX2	-	00	-	030	-	1000	-	CO0T	-	D9M
--	--------	---	----	---	-----	---	------	---	------	---	-----

Series / Type: LIMAX2 = LIMAX02 (1-Kanal)

SN-number:
 00 = standard version
 01 = special version

Signal cable length:
 030 = 3,0 m (Standard)
 050 = 5,0 m
 Other on request

Resolution:
 62N5 = 62,5 μm = 0,0625 mm
 0125 = 125 μm = 0,125 mm
 0250 = 250 μm = 0,25 mm
 0500 = 500 μm = 0,50 mm
 1000 = 1000 μm = 1,00 mm

Interface:
 2320 = RS232 [standard protocol, RS232 / position]
 2321 = RS232 [extended protocol RS232 / position & speed]

 4220 = RS422 [standard protocol, RS422 / position]
 4221 = RS422 [extended protocol RS422 / position & speed]

 4850 = RS485 on request

 CN0 = CAN [standard protocol, basic-CAN]
 CO0 = CANopen [Encoder Profil DS406]
 CO1 = CANopen [Elevator Profil DS417]

 PNO = Profibus [according to IEC61158/IEC61784, standard ID 5, other on request]

 SSB0 = SSI-Interface [25-bit binary code / position]
 SSG0 = SSI-Interface [25-bit gray code / Position]

CAUTION:
 -> CAN Interface is optional available with galvanic isolation / assembly CAN-load resistor selectable
 -> RS232- Interface is never terminated!
 -> RS422- & RS485- & SSI- Interface is basically terminated!

CAN Interface	Without galvanic isolation	With galvanic isolation (G)
Terminated 120R (T)	CN0T (Standard)	CN0TG
Not terminated	CN0	CN0G
Terminated 120R (T)	CO0T (Standard)	CO0TG
Not terminated	CO0	CO0G
Terminated 120R (T)	CO1T	CO1TG
Not terminated	CO1 (Standard)	CO1G

SSI Interface	
Without optocoupler at clock input (terminated 120R)	With optocoupler at clock input (G) (terminated 120R)
SSB0 (Standard)	SSB0G
SSG0 (Standard)	SSG0G

Options:
 (Multiple choice possible)
 U = option unguided
 PNO = 1 pc. Flange plug M8, 1 pc. Flange plug M12 und 1 pc. Flange socket M12
 D9M = 9-pol. D-Sub-connector [CAN & CANopen]
 D9M1 = 9-pol. D-Sub-connector [SSI / option NEWLIFT FST2]
 D9M3 = 9-pol. D-Sub-connector [SSI / option LödigeSEW]
 D9F0 = 9-pol. D-Sub-socket [RS232 / to connect to DEE/DTE]
 (open cable end if no option is selected!)

Figure 36: Type designation





12.1 Control specific Sensors

Table 14: Control specific Sensors

Product key	Control type
LIMAX2-00-030-0500-CO1TG-D9M	Böhnke bp306/bp308 (CANopen CiA 417) - terminated
LIMAX2-00-030-0500-CO1G-D9M	Böhnke bp306/bp308 (CANopen CiA 417) - not terminated
LIMAX2-00-030-62N5-SSG0-D9M1	NEWLift FST2
LIMAX2-00-030-1000-SSB0	KW Aufzugstechnik David 606
LIMAX2-00-030-1000-CO0	LIMAX2 with CANopen encoder profile DS406
LIMAX2-14-030-1000-SSBX	Kollmorgen MRL4 / MFE4 (MPK400)
LIMAX2-04-015-1000-CO1-D9M	Sodimas Quickinstall
LIMAX2-52-030-1000-CO0G	Securelift

12.2 Accessories

Table 15: Accessories

Order Designation	Description	Image
AB20-80-10-1-R-D-15-BK80	Magnetic Tape	
Guidance LIMAX2 complete	Polymer guide rail with underlay and safety splint	
Installation kit LIMAX MKF	Mounting set for suspended installation with dowel.	
Installation kit LIMAX MKB	Mounting set for suspended installation with guiding rails and rail holder.	
Installation kit LIMAX RMS	Mounting set for suspended installation with cross-beam for standard layout.	
Installation kit LIMAX RMS 90	Mounting set for suspended installation with cross-beam for "Rucksack" layout.	
Installation kit LIMAX S-RMS	Mounting set for suspended installation with cross-beam and tape detection.	
LIMAX2 MW	Mounting flange for LIMAX2	
CD-ROM with GSD File	Supplied with option profibus	
Connection cable power supply PNO	M8 coupling, 4-pin 5 m length	
PROFIBUS – signal line	M12 connector, 5-pin, b-coded (assembled at one end) 5 m length	
PROFIBUS – signal line	M12 coupling, 5-pin, b-coded (assembled at one end) 5 m length	
PROFIBUS – signal line	M12 plug / socket (assembled at both ends) 5 m length	
PROFIBUS - Terminator	M12 4-pin, b-coded	

13 Index

Accessories	42	Maintenance.....	38, 39
Accident prevention regulations.....	6	Operating area	16
CAN Interface and Protocols.....	24	Operational safety.....	6
Causes of risk.....	8	Option Profibus Interface	36
Cleaning.....	38, 39	Order reference	12
Connections	24	Packaging material.....	10
Conventional use.....	9	Protection against contact	16
Demounting	7	Protective equipment	8
Device number	12	RS232 / RS422 / RS485	32
Dimensions Magnetic Tape.....	14	Safety	6, 8
Dimensions Sensor.....	12	Safety instructions	6
Dimensions Sensor Option unguided.....	13	Safety rules	6
Disposal.....	7	Sensor	
Disturbances	38	Technical Data Sensor	14
Explanation of symbols.....	6	Sensor Construction	11
Fault clearance.....	38	SSI Interface.....	31
First start-up	16	Start-up	16
Identification	12	Statement of warranties.....	7
Installation	16	Storage	10
Installation of the Sensor	18	Technical Data Magnetic Tape	15
Interfaces	24	Transport	10
LED status notice	24	Transport damage.....	10
Magnetic tape		Type designation	12
Structure	15		

Document- No.: D-103920 / Rev. 1
Document- Name : LIMAX2-00-MA-E
Subject to change - © 2020
ELGO Electronic GmbH & Co. KG

ELGO Batscale AG

Messen | Steuern | Positionieren

Föhrenweg 20, FL-9496 Balzers
Tel.: +423 (0) 380 02 22, Fax.: +423 (0) 380 02 24
Internet: www.elgo.li, Mail: info@elgo.li

