

Operating Manual

SERIES LIMAX2M

Magnetic Absolute Shaft Information System
(Translation of the original operating manual)

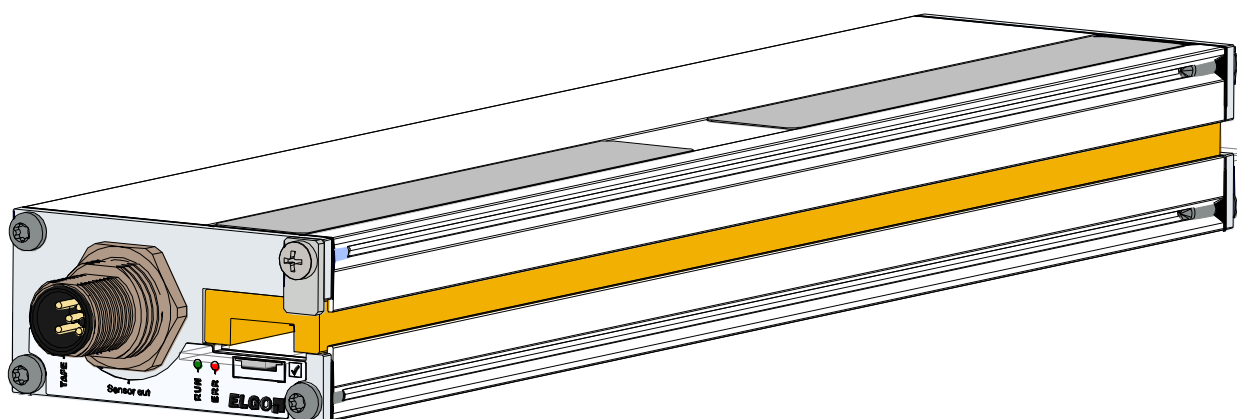

- Position measuring for lifting heights up to 130 meters
- Travel speed up to 4 m/s
- Insensitive to dirt, smoke and humidity
- Resolution up to 0.0625 mm
- Easy and flexible mounting
- No referencing necessary
- Magnetic tape may be installed vertically freely suspended or horizontally
- Wear-free, contactless and noiseless measuring principle

Publisher ELGO Batscale AG
Föhrenweg 20
FL-9496 Balzers

Technical Support  +49 (0) 7731 9339 – 0
 +49 (0) 7731 2 88 03
 support@elgo.de

Document- No. D-103918

Document - Name LIMAX2M-00-MA-E_06-20

Article Number 799000722

Document- Revision Rev. 2

Issue Date 2020-02-07

Copyright © 2020, ELGO Batscale AG

1 Contents

1	Contents	3
2	General	4
2.1	Information Operating Manual	5
2.2	Explanation of Symbols	5
2.3	Statement of Warranties	6
2.4	Demounting and Disposal	6
3	Safety	7
3.1	General Causes of Risk.....	7
3.2	Personal Protective Equipment.....	7
3.3	Conventional Use	8
4	Transport and Storage	9
4.1	Safety Instructions for Transport, Unpacking and Loading	9
4.2	Handling of Packaging Material	9
4.3	Inspection of Transport	9
4.4	Storage	9
5	Product Features	10
5.1	Functional principle.....	10
6	Technical Data	11
6.1	Identification	11
6.2	Dimensions Sensor.....	11
6.3	Dimensions Magnetic Tape	12
6.4	Technical Data Sensor	12
6.5	Technical Data Magnetic Tape.....	13
7	Installation and First Start-Up.....	14
7.1	Operating Area	14
7.2	Description Mounting / Installation of the Sensor.....	15
7.3	Description installation / Mounting of the Magnetic Tape	16
8	Connections and Interfaces	22
8.1	LEDs (Operating Status and Notices).....	22
8.2	CAN Interface	23
8.3	SSI Interface.....	29
8.4	RS422 and RS485* Interface	30
9	Disturbances, Maintenance, Cleaning.....	34
9.1	Fault Clearance.....	34
9.2	Re-start after Fault Clearance.....	34
9.3	Maintenance.....	35
9.4	Cleaning	35

10	Type Designation	36
10.1	Accessories	37
11	Index	43

2 List of Figures

Figure 1: Sensor Construction	10
Figure 2: Dimensions LIMAX2M	11
Figure 3: Dimensions Magnetic Tape	12
Figure 4: Installation with tension weight	15
Figure 5: Installation with spring	15
Figure 6: Mounting groove on the sensor	16
Figure 7: Assessment of the pretention of the magnetic tape	17
Figure 8: Correct orientation of the magnetic tape	18
Figure 9: Distance and orientation of the magnetic tape in relation to the sensor	18
Figure 10: Assessment of the guiding rail of the tape in the sensor - twisted magnetic tape	19
Figure 11: Assessment of the guiding rail of the tape in the sensor - skewed mounting of the magnetic tape ...	19
Figure 12: Assessment of the vertical alignment of the sensor	20
Figure 13: LED signals on the upper side of the sensor	22
Figure 14: Protocol DS406	23
Figure 15: Protocol DS417	23
Figure 16: Setting the Heartbeat Cycle Duration	24
Figure 17: Setting the Sending Cycle for the position data	25
Figure 18: Saving the parameters	25
Figure 19: Changing the device into the Operational Mode	26
Figure 20: Changing the device into the Pre-operational Mode	26
Figure 21: Changing the device into the Stopped Mode	26
Figure 22: Changing into the LSS Configuration Mode	27
Figure 23: Saving the parameters in the LSS Mode	27
Figure 24: Setting the Baud rate	28
Figure 25: Setting the node-ID	28
Figure 26: Data Protocol SSI	29
Figure 27: Data Protocol Version 4221	30
Figure 28: Data Protocol Versions 4220 / 4850	30
Figure 29: Connection to a RS422 Master	32
Figure 30: Cable M12F5 - open cable ends	37
Figure 31: Cable M12F5 - D9M	38
Figure 32: Cable M12F - open cable ends	38
Figure 33: Cable M12F - D9M1	39
Figure 34: Mounting angle	40

3 List of Tables

Table 1: Configuration of CANopen DS406	23
Table 2: Configuration of CANopen DS417	23
Table 3: Pin Assignment CAN	23
Table 4: Pin Assignment SSI	29
Table 5: Error-codes of an addressable LIMAX2M	32
Table 6: Pin Assignment RS422	33
Table 7: Pin Assignment RS485	33
Table 8: Connections Cable M12F5 - open cable ends	37
Table 9: Connections Cable M12F5 - open cable ends	38
Table 10: Connections Cable M12F - open cable ends	39
Table 11: Connections M12F - D9M1	39

4 General

4.1 Information Operating Manual

This manual contains important information regarding the handling of the device. For your own safety and operational safety, please observe all safety warnings and instructions.

Precondition for safe operation is the compliance with the specified safety and handling instructions. Moreover, the existing local accident prevention regulations and the general safety rules at the site of operation have to be observed.

Please read the operating manual carefully before starting to work with the device! It is part of the product and should be kept close to the device and accessible for the staff at any time. The illustrations in the manual are for better demonstration of the facts. They are not necessarily to scale and can slightly differ from the actual design.



4.2 Explanation of Symbols

Special notes in this manual are characterized by symbols.

The notes are introduced by signal words which express the magnitude of danger.

Please follow this advice and act carefully in order to avoid accidents and damage and injuries.

Warning notes:

	<p>DANGER! This symbol in connection with the signal word "Danger" indicates an immediate danger for the life and health of persons. Failure to heed these instructions can result in serious damage to health and even fatal injury.</p>
	<p>WARNING! This symbol in connection with the word „Warning“ means a possibly impending danger for the life and health of persons. Failure to heed these instructions can result in serious damage to health and even fatal injury.</p>
	<p>CAUTION! This symbol in connection with the signal word "Caution" indicates a possibly dangerous situation. Failure to heed these instructions can lead to injuries or damage of property.</p>



Special safety instructions:

	<p>DANGER! This symbol in connection with the signal word "Danger" indicates an immediate danger for the life and health of persons due to voltage. Failure to heed these instructions can result in serious damage to health and even fatal injury. The operations may only be carried out by a professional electrician.</p>
---	---

Tips and recommendations:

	<p>NOTE! ... points out useful tips and recommendations as well as information for an efficient and trouble-free operation.</p>
---	--

References:

-  1.2) Marks a reference to chapter 1.2 of this manual.
-  DOC 3.4) Marks a reference to chapter 3.4 of the document *DOC*.

4.3 Statement of Warranties

The statement of warranties is enclosed separately in the sales documents.

Guarantee

The producer guarantees the functional capability of the process engineering and the selected parameters. The period of warranty is one year and begins with the date of delivery.

4.4 Demounting and Disposal

Unless acceptance and disposal of returned goods are agreed upon, demount the device considering the safety instructions of this manual and dispose it with respect to the environment.

Before demounting:

Disconnect the power supply and secure against re-start. Then disconnect the supply lines physically and discharge remaining energy. Remove operational supplies and other material.

Disposal:

Recycle the decomposed elements:

- Metal components in scrap metal
- Electronic components in electronic scrap
- Recycle plastic components
- Dispose the remaining components according to their material consistence

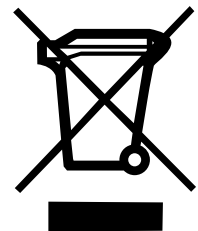

CAUTION!

Wrong disposal causes environmental damages! Electronic scrap, electronic components, lubricants and other auxiliary materials are subject to special refuse and can only be disposed by authorized specialists!

Local authorities and waste management facilities provide information about environmentally sound disposal.

5 Safety

	<p>CAUTION!</p> <p>Please read the operating manual carefully, before using the device! Observe the installation instructions! Only start up the device if you have understood the operating manual.</p> <p>The operating company is obliged to take appropriate safety measure. The initial operation may only be performed by qualified and trained staff.</p> <p>Selection and installation of the devices as well as their embedding into the controlling system require qualified knowledge of the applicable laws and normative requirements on the part of the machine manufacturer.</p>
---	--

5.1 General Causes of Risk

This chapter gives an overview of all important safety aspects to guarantee an optimal protection of employees and a safe and trouble-free operation. Non-observance of the instructions mentioned in this operating manual can result in hazardous situations.



5.2 Personal Protective Equipment

Employees have to wear protective clothing during the installation of the device to minimize danger of health.

Therefore:

Change into protective clothing before performing the works and wear them throughout the process. Additionally observe the labels regarding protective clothing in the operating area.

Protective clothing:

	<p>PROTECTIVE CLOTHING</p> <p>... is close-fitting working clothing with light tear strength, tight sleeves and without distant parts. It serves preliminarily for protection against being gripped by flexible machine parts. Do not wear rings, necklaces or other jewelry.</p>
	<p>PROTECTIVE GLOVES</p> <p>... for protecting the hands against abrasion, wear and other injury of the skin.</p>
	<p>PROTECTIVE HELMET</p> <p>... for protection against injuries of the head.</p>

5.3 Conventional Use

The product described in this manual was developed to execute safety-related functions as a part of an entire assembly or machine. It is the responsibility of the manufacturer of a machine or installation to ensure the proper operation of the system. The ELGO-device is conceived only for the intended use described in this manual.

The LIMAX2M - ELGO- length measuring system serves only to measure lengths.



CAUTION!

Danger through non-conventional use! Non-intended use and non-observance of this operating manual can lead to dangerous situations.

Therefore:

- Only use the device as described
- Strictly follow the instructions of this manual

Avoid in particular:

- Remodeling, refitting or changing of the construction or single components with the intention to alter the functionality or scope of the device.

Claims resulting from damages due to non-conventional use are not possible.
Only the operator is liable for damages caused by non-conventional use.

6 Transport and Storage

6.1 Safety Instructions for Transport, Unpacking and Loading

**CAUTION!**

Transport the package (box, palette etc.) professionally. Do not throw, hit or fold it.

6.2 Handling of Packaging Material

Notes for proper disposal: ☞ 2.5

6.3 Inspection of Transport

Check the delivery immediately after the receipt for completeness and transport damage.

In case of externally recognizable transport damages:

- Do not accept the delivery or only accept under reserve.
- Note the extent of damages on the transportation documents or delivery note.
- File complaint immediately.

**NOTE!**

Claim any damage immediately after recognizing it. The claims for damage must be filed in the lawful reclaim periods.

6.4 Storage

Store the device only under the following conditions:

- Do not store outside
- Keep dry and dust-free
- Do not expose to aggressive media
- Protect from direct sun light
- Avoid mechanical shocks
- Storage temperature (☞ 6 Technical Data) needs to be observed
- Relative humidity (☞ 6 Technical Data) must not be exceeded
- Inspect packages regularly if stored for an extensive period of time (>3 months)

7 Product Features

The absolute shaft information system LIMAX2M with its significant advantages is a particularly affordable, non-sensitive and easy-to-install alternative to conventional shaft information systems. Due to the absolute measurement principle, referencing is not required after commissioning.

Compared to other shaft information systems, LIMAX2M is characterized by an extraordinarily low price. LIMAX2M is able to cover lifting heights up to 130 meters and speeds up to 4 m/s. The standard interfaces are CAN, RS422 or SSI. We also provide customized solutions on request.

This measuring system provides smallest sensor of the entire LIMAX series. With these small space requirements, LIMAX2M is ideal for remodelling and modernization.

A simple and flexible mounting ensures quick installation or replacement of the measuring system.

Features:

- Robust measuring principle to dirt, smoke and humidity
- Easy and flexible mounting
- No reference necessary
- Wear-free, contactless and noiseless measuring principle

7.1 Functional principle

The tape carries the unique positioning information as a magnetic code. It is installed free hanging in the elevator shaft by use of a mounting kit. The sensor head is mounted to the elevator car. While the actual measurement is contactless the tape must be kept within a maximum distance to the sensor head. Therefore, the tape is guided along the sensor by use of the polymer tape guide which is an integral component of the sensor head.

The magnetic measurement principle is extremely robust. Dust, dirt and humidity do not affect the measurement in any way. Also, smoke and even higher temperatures have no influence on the measuring quality. Therefore, LIMAX2M is particularly suited for application in fire fighter elevators. Also is the tape robust enough to withstand the sometimes-harsh conditions in elevator shafts.

7.2 Sensor Construction

The LIMAX2M sensor consists of the following components:

- Sensor housing with integrated signal LEDs for signaling various states.
- M12 round connector (5-pin) for power supply and communication with the lift control.
- Guide rail with plastic underlay (keeps the magnetic tape at a defined distance from the sensor).
- Holding plate for mechanical fixation of the polymer guide rail.

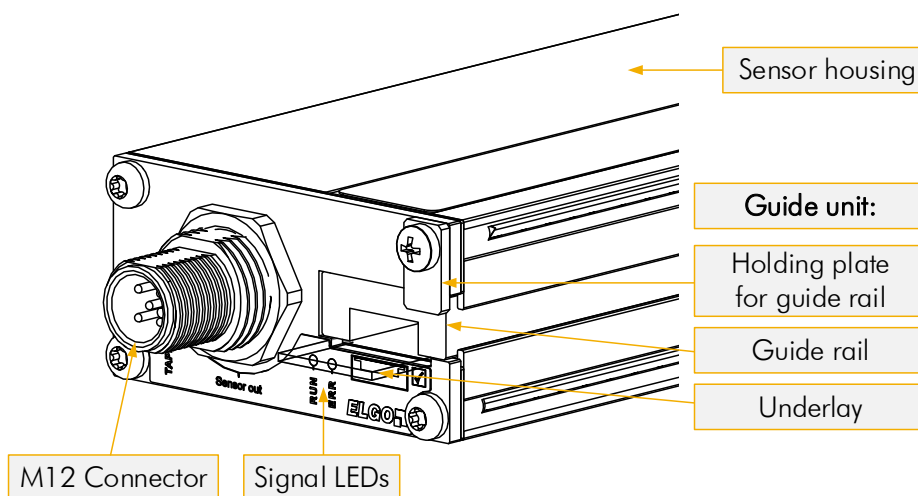

Figure 1: Sensor Construction

8 Technical Data

8.1 Identification

The type label serves for the identification of the unit. It is located on the housing of the sensor and gives the exact type designation (=order reference, see type designation) with the corresponding part number. Furthermore, the type label contains a unique, traceable device number. When corresponding with ELGO always indicate this data.

8.2 Dimensions Sensor

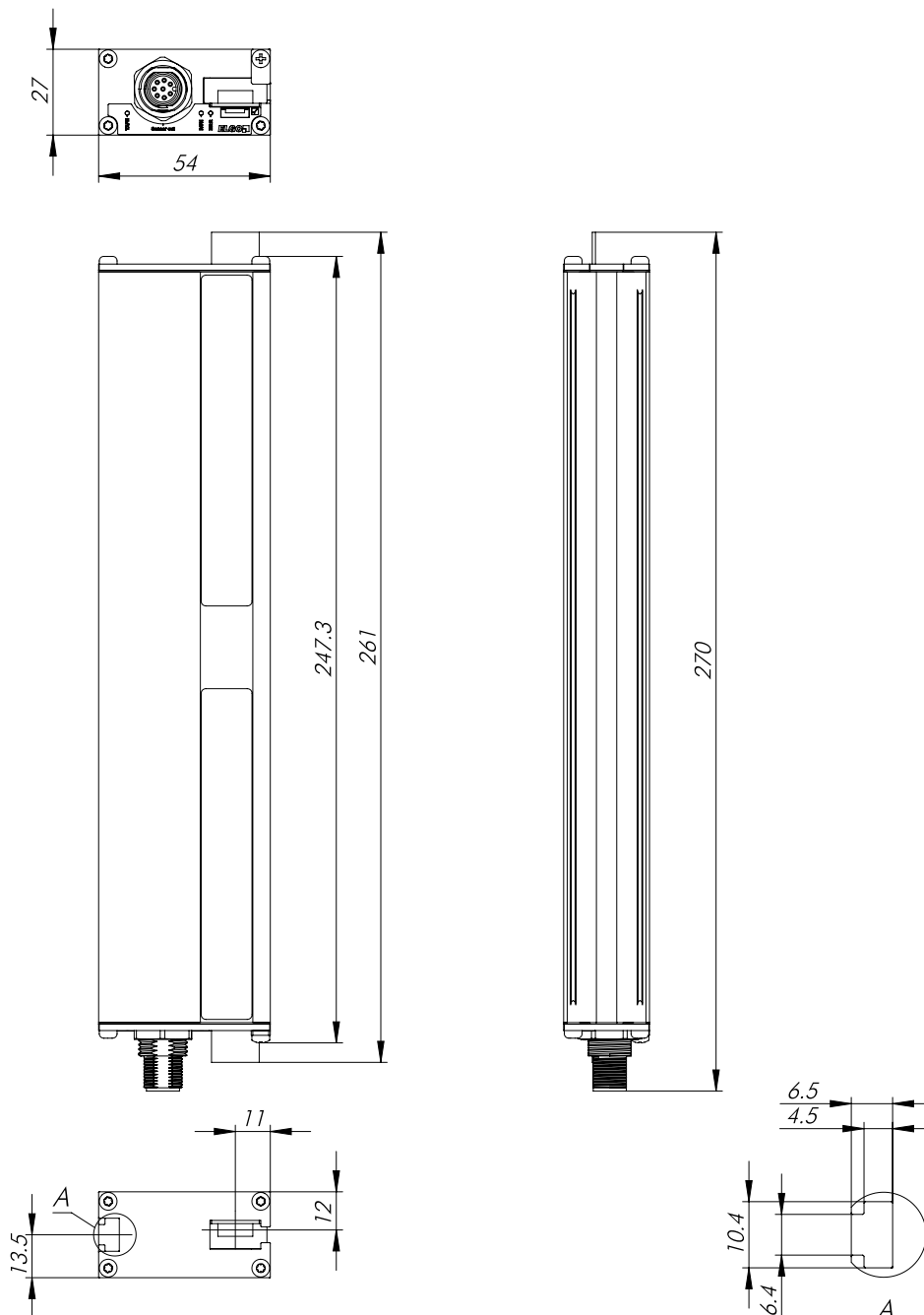

Figure 2: Dimensions LIMAX2M

8.3 Dimensions Magnetic Tape

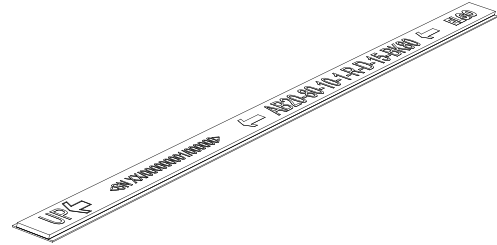
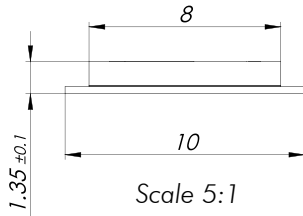

Figure 3: Dimensions Magnetic Tape

8.4 Technical Data Sensor

LIMAX2M (Standard version)

Mechanical Data

Measuring principle	absolute
Repeat accuracy	±1 mm
System accuracy in μm at 20°C	$\pm(1000 + 50 \times L)$ L = measuring length in meter
Basic pole pitch	8 mm
Sensor housing material	aluminium
Sensor housing dimensions	L x W x H = 247 x 54 x 27 mm
Necessary type	AB20-80-10-1-R-D-15-BK80
Maximum measuring length	130 m
Connection	<ul style="list-style-type: none"> ▪ M12 round connector ▪ RJ45 plug with fixed cable outlet on request
Weight	approx. 320 g
Sensor cable	3 m standard cable length (other on request)

Electrical Data

Supply voltage	10 ... 30 VDC
Residual ripple	< 200 mVpp
Power input	max. 0.2 A
Interfaces	☞ 12
Resolution	☞ 12
Speed	max. 4 m/s

Conditions

Storage temperature	-20 ... +85 °C
Operation temperature	-10 ... +70 °C (-25 ... +85 °C on request)
Humidity	max. 95 %, not condensing
Protection class	IP54 (IP67 on request)

8.5 Technical Data Magnetic Tape

The magnetic tape consists of two components:

- The actual magnetic tape which carries the position information
- A mechanical stainless steel back iron

TEMPLATE Magnetic Tape AB20-80-10-1-R-D-15-BK80





Coding	absolute, one track system
Pole pitch	8 mm
Operation temperature installed	-20 ... +65 °C (-20 ... +80 °C when using without adhesive tape, options „B“ or „D“)
Storage temperature uninstalled	Short-term: -10 ... +60 °C Medium-term: 0 ... +40 °C Long-term: +18 °C (-20 ... +80 °C when using without adhesive tape, options „B“ or „D“)
Gluing temperature	+18 °C ... +30 °C
Relative humidity	max. 95 %, non-condensing
Accurateness 20°C in μm	± (1000 + 50 x L) L = measuring length in meters
Material carrier tape	Precision strip 1.4310 / X10CrNi 18-8 (EN 10088-3)
Double-faced adhesive tape	3M-9088 (observe instructions), others on request
Dimensions	→ without adhesive tape: 10 mm (±0.1) x 1,35 mm (±0.11) → with adhesive tape (excl. carrier): 10 mm (±0.1) x 1,56 mm (±0.13) → with adhesive tape (incl. carrier): 10 mm (±0.1) x 1.63 mm (±0.14)
Length expansion coefficient	$\alpha \approx 16 \times 10^{-6} \text{ 1/K}$
Thermal length expansion	$\Delta L[\text{m}] = L[\text{m}] \times \alpha[1/\text{K}] \times \Delta \vartheta[\text{K}]$ (L = tape length in meters, $\Delta \vartheta$ = relative temperature change)
Bending radius	min. 150 mm
Available lengths	max. 260 m
Weight magnetic tape	ca. 62 g/m (incl. magnetic tape and cover tape)
Tape imprint	ELGO standard, printing color black, digit height ≥ 5 mm
Influence of external magnets	External magnetic fields must not exceed 64 mT (640 Oe; 52 kA/m on the surface of the magnetic tape as this could damage or destroy the code on the tape.
Protection class	IP65

9 Installation and First Start-Up

	<p>CAUTION Please read the operating manual carefully before using the device! Strictly observe the Installation instructions! In case of damage caused by failure to observe this operating manual, the warranty expires.</p> <p>ELGO is not liable for any secondary damage and for damage to persons, property or assets.</p> <p>The operator is obliged to take and to realize appropriate safety measures.</p> <p>The operator is obliged to take appropriate safety measures. The first start-up may only be performed by staff that has been trained and authorized by the operator.</p>
---	--

9.1 Operating Area

	<p>WARNING! Do not use the device in explosive or corrosive environments! The device must not be installed close to sources of strong inductive or capacitive interference or strong electrostatic fields!</p>
---	---

	<p>CAUTION! The electrical connections must be made by suitably qualified personnel in accordance with local regulations.</p>
	<p>The device may be designed for switchboard mounting. During work on the switchboard, all components must be de-energized if there is a danger of touching the energized parts! (protection against contacts)</p>
	<p>Wiring works may only be performed in the de-energized state!</p> <p>Thin cable strands have to be equipped with end sleeves!</p> <p>Before switching on the device, connections and plug connectors have to be checked!</p>
	<p>The device must be mounted in a way that it is protected against harmful environmental influences such as splashing water, solvents, vibration, shock and severe pollution and the operating temperature must not be exceeded.</p>

9.2 Description Mounting / Installation of the Sensor

9.2.1 Installation Principle

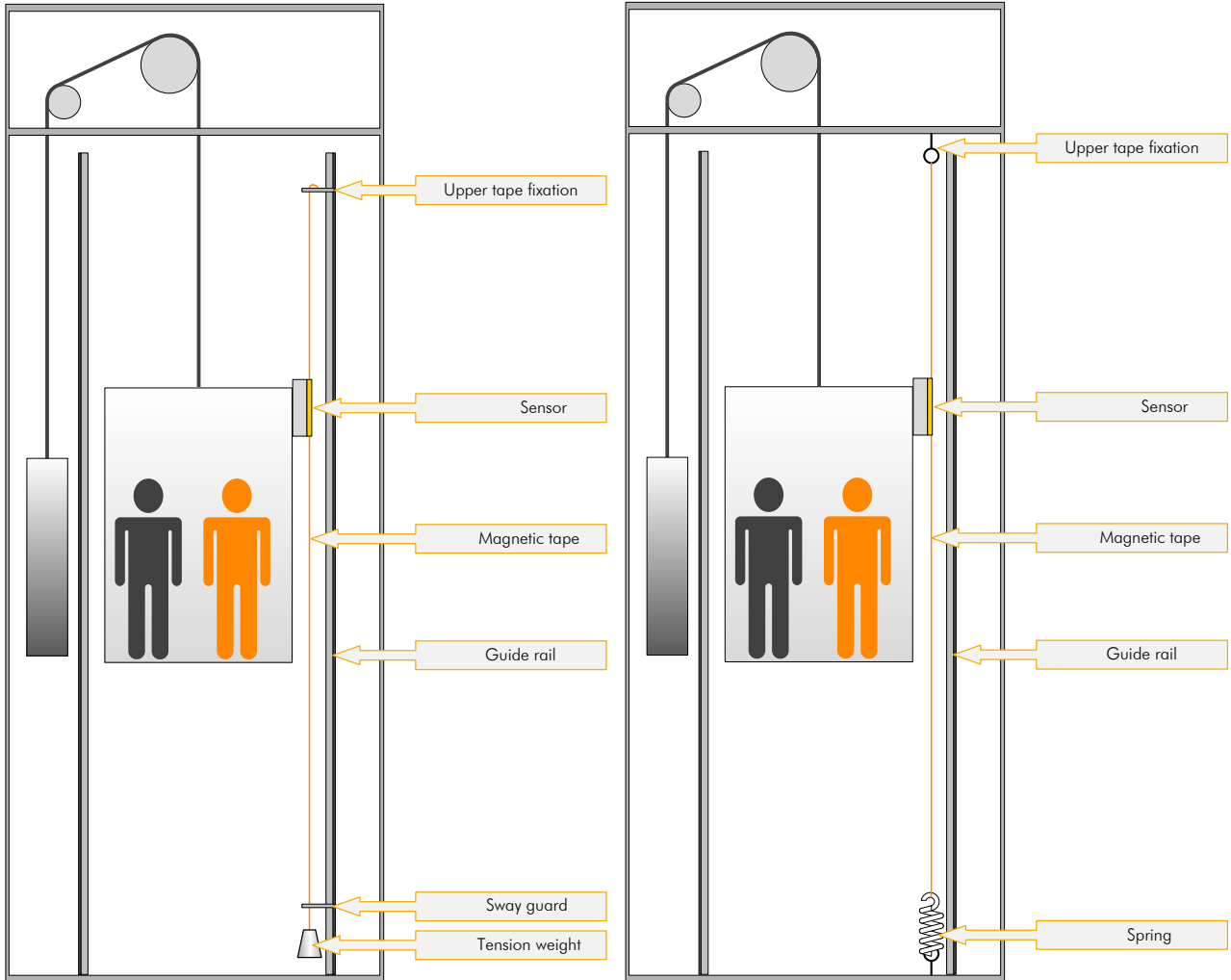

Figure 4: Installation with tension weight

Figure 5: Installation with spring

LIMAX2M can be installed at any position in the shaft, depending on space situation and layout of the particular elevator installation.

The magnetic tape is installed freely suspended in the shaft. It can be fixed with the RMS mounting kit (available as option) on the guide rail. Alternatively fixation in the shaft head is either on beams or directly bolted into the ceiling. The necessary tension in the tape is provided by a tension weight of about 5kg. A sway guard at the bottom is recommended. This will keep the tape from swaying in an uncontrolled manner which may cause damage to the tape or other components in the shaft. Alternatively the magnetic tape can be tensioned by a spring.

The sensor head can be mounted onto the car body or car frame – again depending on the specific conditions of the elevator.

9.2.1 Installation of the Sensor

The sensor is fixated on the cabin or on the car frame. The mounting position is basically determined by the condition.

The integrated mounting notch on the housing of the sensor head allow for a very simple and self-explanatory installation from one side. You can either use M6 hexagon head screws (DIN 933) or M6 square nuts (DIN 562), to mount the system at the desired position.

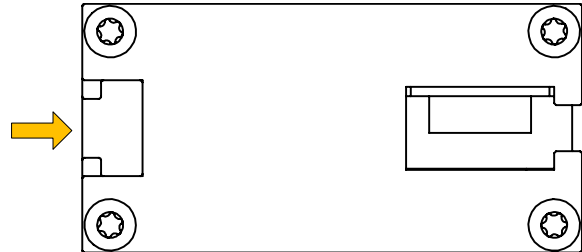



Figure 6: Mounting groove on the sensor

	<p>NOTE During installation of the magnetic tape in the sensor, pay attention to the marks on the magnetic tape and on the sensor head.</p> <p>Wrong orientation of tape vs. Sensor head will yield incorrect position readings! The arrows printed on the magnetic tape and sensor head point in positive counting direction (in the direction of the shaft head)!</p>
---	---

9.3 Description installation / Mounting of the Magnetic Tape

	<p>NOTE External Magnetic Fields The influence of the magnetic tape by magnetic fields must be avoided! The magnetic tape must not come into direct contact with other magnetic fields (e.g. permanent magnets, magnetic clamps, electromagnets, magnetic stands)! This may cause irreparable damage, which will compromise the measuring accuracy or even the functioning.</p>
---	--

9.3.1 General Information

The technology has proven to be highly robust. LIMAX2M will work under the most adverse environmental conditions. Extreme temperatures, high moisture and excessive soiling will not alter the information coded onto the tape nor will these conditions affect reading precision of the sensor. Even weak magnetic fields such as they are generated by door magnets can be tolerated.

If some basic rules and guidelines are followed LIMAX2M systems require a minimum amount of installation and maintenance effort while offering maximum lifetime.

One important issue to consider is the protection of the magnet tape against mechanical wear. The LIMAX2M tape consists of two components:

- The magnetic tape which actually carries the position information
- A protective steel tape which gives the mechanical properties

9.3.2 Installation Concept

9.3.2.1 Basic principle for the mounting

	<p>NOTE! The magnetic tape itself is not designed to withstand excessive mechanical wear. It is therefore important to ensure that the system is installed such that the mechanical contact between tape and sensor head is mainly between the steel tape and the polymer sensor guide. These two materials have been specifically paired for this application.</p>
---	---

Avoiding contact between the magnetic side and the sensor could be achieved with a perfectly perpendicular installation of the band. Yet, in reality this is not practicable. It is therefore preferable to install the tape with a horizontal offset from the sensor. During operation this method will result in a forced contact between the steel side of the band and the polymer guide of the sensor which guarantees an optimal operation of the system.

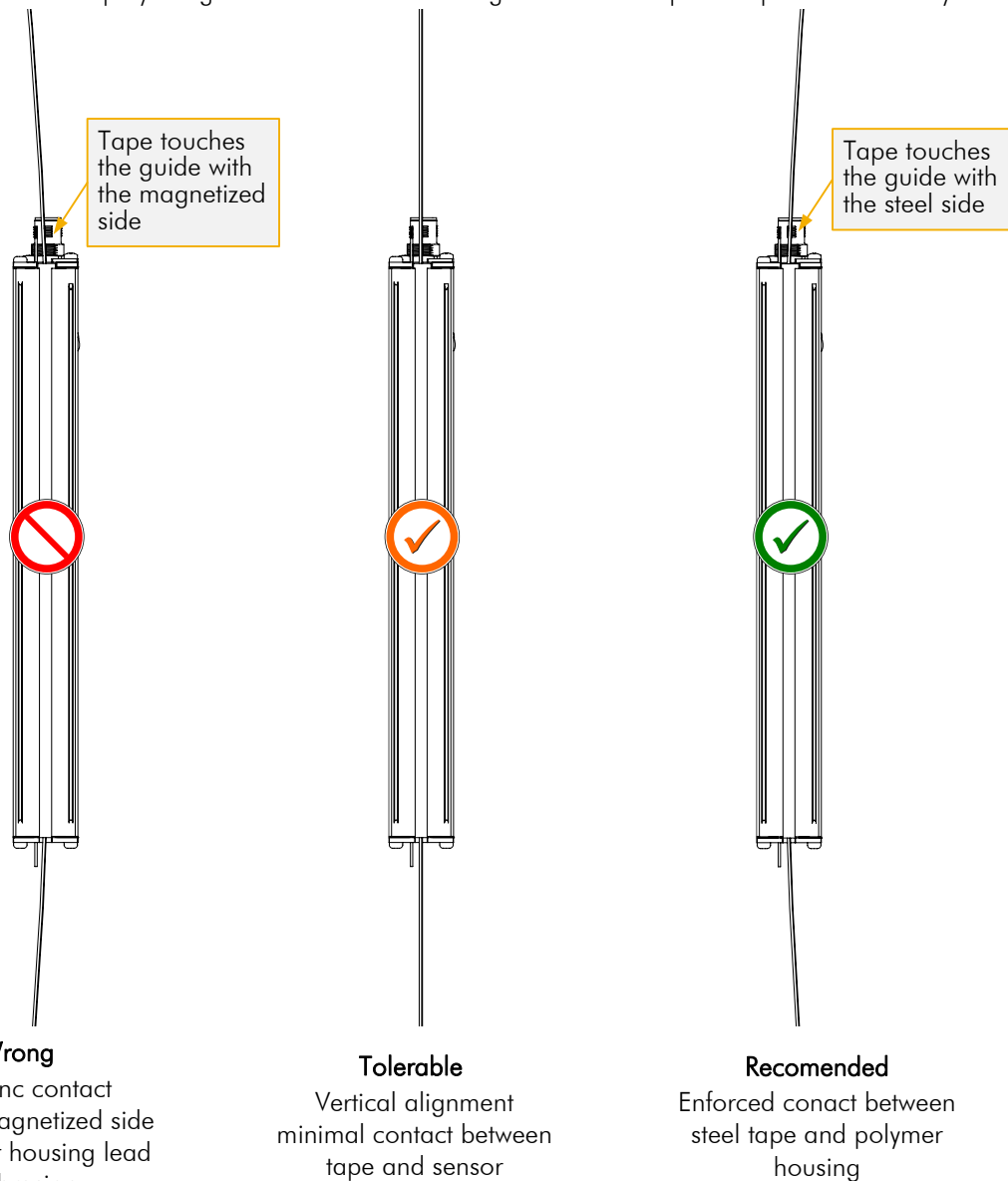

Figure 7: Assessment of the pretention of the magnetic tape

9.3.3 Installation Procedure

1. Attach the top end of the tape in the shaft head. Ideally use an ELGO Mounting Kit. Check for correct orientation of the tape. The arrows on the magnetic side must point in upward direction.



Figure 8: Correct orientation of the magnetic tape

2. The magnetic side of the tape must face the sensor body. In most situations this means that the steel side points to the shaft wall.
3. Drive down the shaft with inspection speed and unroll the tape. The ELGO tape packaging system has been specifically designed for this purpose. The tape can be unwound directly from the box without opening.
4. Attach the tension weight (about 7.5 kg) at the bottom end of the tape in the shaft. Secure the tape with a sway guard. Pay attention to a proper vertical mounting of the tape.
If you use dowels to fix the tape in the shaft, tighten the spring such, that the according tractions results to minimum 7.5 kg. When using the ELGO Mounting Kit RMS/RMS90 this is equivalent to a spring elongation of about 90mm.
Note that slightly higher tensile forces are never a problem, but avoid under-tensioning. In higher buildings it may even be preferable to slightly increase the tension in order to prevent flapping of the tape during operation. However, if correctly installed tensile forces of more than 10 kg should never be necessary.
5. Drive the car to the middle of the shaft.
6. Attach the sensor to the car. The side with the cable outlet and the LED's must face upward.
7. Adjust the sensor using the tape as a reference. First, align sensor and magnet band on their centerline.

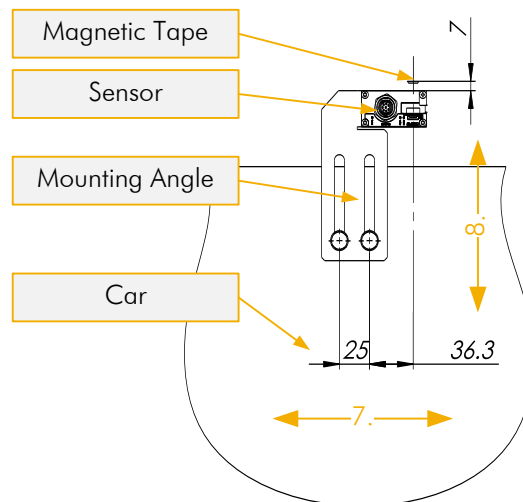

Figure 9: Distance and orientation of the magnetic tape in relation to the sensor

8. Adjust now the distance between sensor and tape. Up to a travel height of 50m we recommend an offset of at least 7 mm. This will ensure steady contact between steel side of the band and the polymer guide of the sensor. This level can be increased later, if it turns out that the band still rubbing with the magnetic side on the sensor.
In higher installations this distance may be increased by the initial assembly up to 5 cm.
Pay attention to a perpendicular alignment of the sensor. Misalignment will lead to increased wear.
9. Pass the tape through the sensor. Loosen the splint-pin and release the polymer guide. Insert the tape and re-attach the guide with the tape in its position.
10. Pay attention that the pad does not slip after removal of the polymer guide from the aluminium guide out and drops down in the shaft.
11. Check for proper alignment of band vs. sensor. Any angular offset should be corrected.

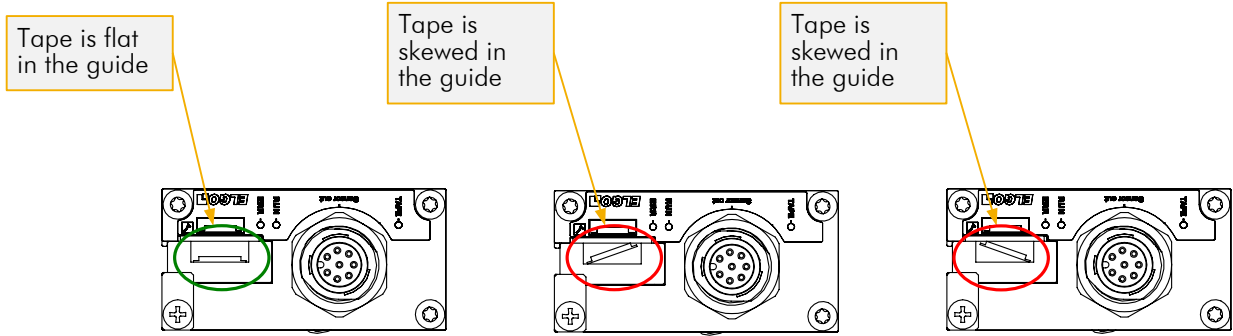

Figure 10: Assessment of the guiding rail of the tape in the sensor - twisted magnetic tape

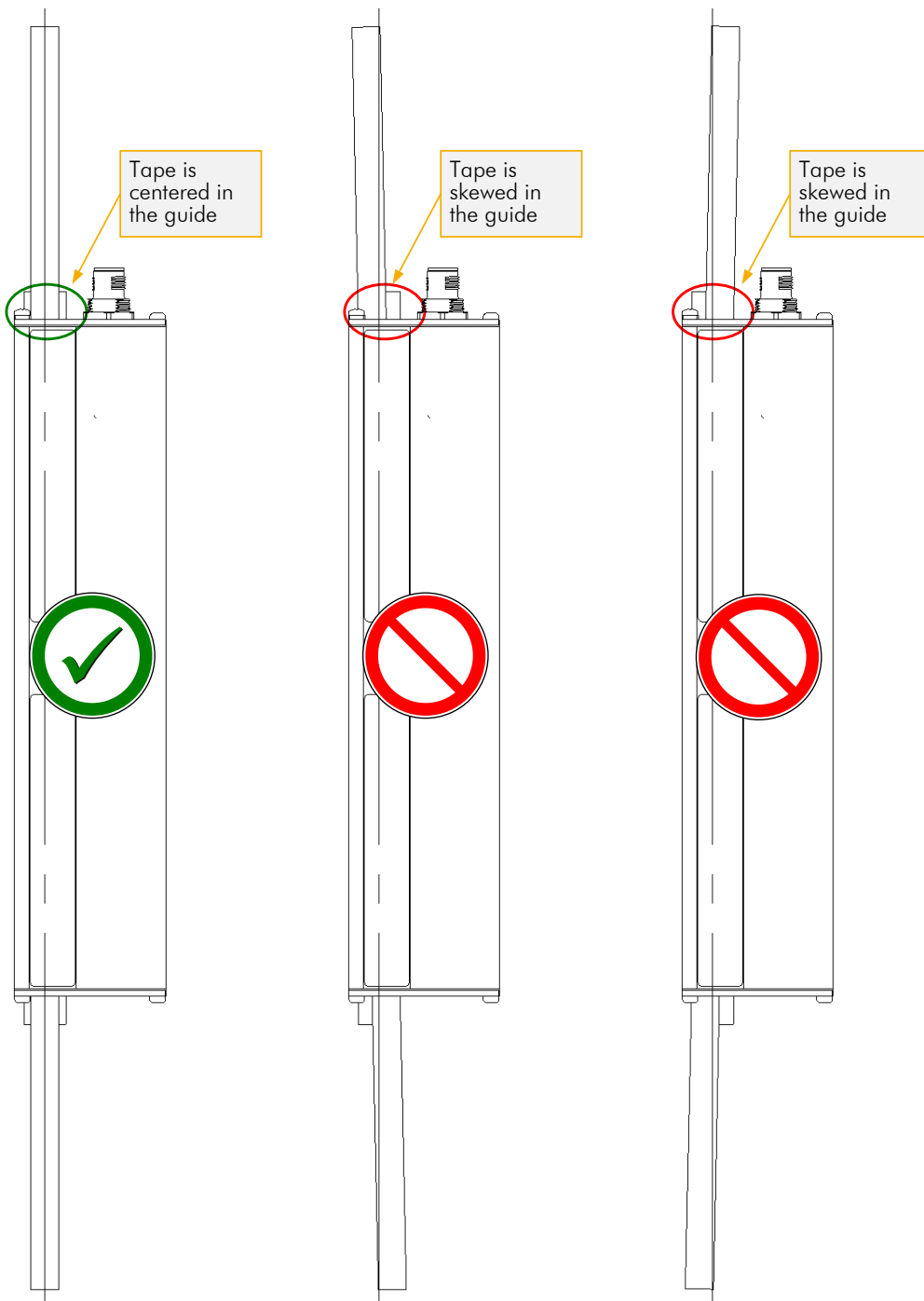

Figure 11: Assessment of the guiding rail of the tape in the sensor - skewed mounting of the magnetic tape

12. IMPORTANT: Installation Check!

Values for tape tension and offset between tape and sensor are guidelines based on experience. But in any case, a proper check after installation is mandatory. **It must absolutely be avoided that the magnetic side constantly grinds on the sensor body during operation.**

Run an inspection trip along the complete shaft. Observe the system and pay attention to the respective positions of band and sensor. You have achieved an optimal installation if the steel side of the tape is constantly pressed slightly against the polymer guide of the sensor. At some points in the shaft also double-check on the bottom side of the sensor. If the sensor is tilted it may look good on top but the tape can still grind along the bottom edge of the sensor.



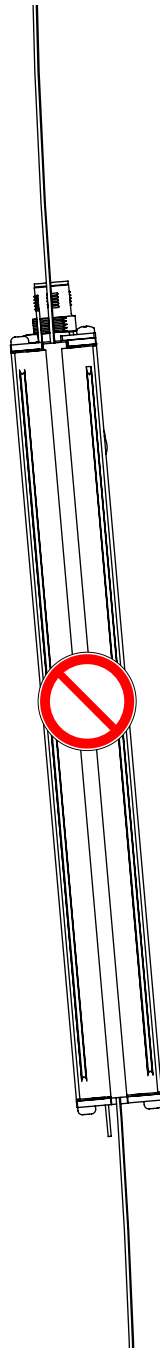

Recomended



Wrong vertical alignment

Figure 12: Assessment of the vertical alignment of the sensor

13. If the installations check reveals that the tape slides on magnetic side, start to increase the offset between sensor and tape. Values of up to 5 cm are acceptable. If this measure does not solve the problem it is very likely that the tape is not plumb in the shaft. This is easy to check for, provided your elevator control allows for inspection trips without the absolute position signal: Just take the tape out of the sensor and run an inspection trip along the shaft. Observe the distance between sensor and tape along the travel. Misalignments will become obvious.
Also ensure that the tension on the tape is sufficient. A loosely tensioned tape will hinder proper guiding.
14. After completion of the installation clean the tape. Beginning at the top of the shaft drive down the complete travel distance pulling the magnet tape through a dry clean cloth.

	<p>NOTE!</p> <p>Be specifically alert if steel construction work is taking place in the shaft. Steel particles released by grinding, welding or such work will adhere to the magnetic tape. The tape is insensitive to fine metal dust. However, <u>coarser</u> metal chips can cause problems. Clean this debris off instantly. Repeat the cleaning process before putting the elevator into operation after complete installation.</p>
	<p>DO NOT USE A MAGNET FOR CLEANING!</p> <p><u>Never</u> use a magnet to remove metal chips from the magnetic tape. This will destroy the magnetic code and thus the magnetic tape.</p>
	<p>PROTECTIVE GLOVES!</p> <p>Always wear protective gloves when cleaning the magnetic tape.</p>

10 Connections and Interfaces

10.1 LEDs (Operating Status and Notices)

The LED's located on the front serve for monitoring of operating conditions.

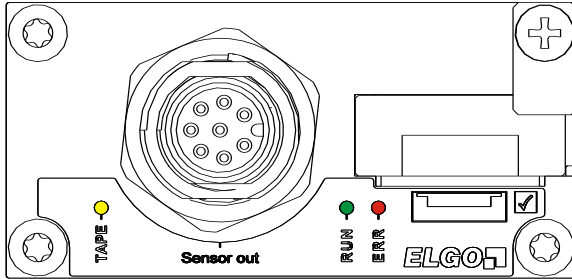

Figure 13: LED signals on the upper side of the sensor

RUN GREEN

For CANopen device	=	RUN-LED according to DR 303-3
Other devices	=	Interface state, flashes during active communication

ERR RED

For CANopen device	=	ERR-LED according to DR303-3
Other devices	=	Error message
ON	=	State error, system not operational
OFF	=	State OK, system ready for operation

TAPPE YELLOW

	→	Indicator for magnet tape
ON	=	Magnet tape missing
OFF	=	Magnet tape available

10.2 CAN Interface

10.2.1 CANopen DS406 and DS417

For LIMAX2M the CANopen Interfaces DS406 (Encoder profile) und DS417 (Lift profile) are available. These interfaces are configured by default as follows:

Table 1: Configuration of CANopen DS406

CANopen DS406	
Bit rate:	250 kbit/s
Identifier:	184 (hex)
Event timer:	10 ms
Producer heartbeat:	500 ms
Resolution:	1.0 mm
First 4 Bytes:	Position in mm
Next 2 Bytes:	Speed in mm/s

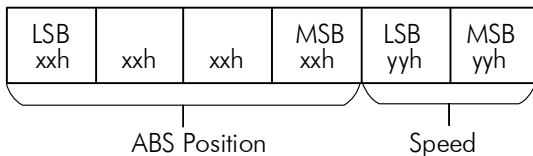

Figure 14: Protocol DS406

Table 2: Configuration of CANopen DS417

CANopen DS417	
Bit rate:	250 kbit/s
Identifier:	18 C (hex) [Node ID 0x04]
Event timer:	0 (switched off)
Producer heartbeat:	500 ms
Resolution:	0.5 mm

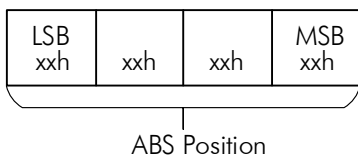

Figure 15: Protocol DS417

10.2.2 Pin Assignment CAN

Table 3: Pin Assignment CAN

5-pin M12 (male) connector	Colour	Function
1	Brown	N.C.
2	White	+24 VDC
3	Blue	0V / GND
4	Black	CAN_H
5	Grey	CAN_L
Housing	Blank	Cable shield

*) please connect shield only at control unit side!

10.2.3 Command Descriptions

10.2.3.1 Initial Operation

After starting the CANopen device is in the Pre-operational Mode (☞ 10.2.5.2) and therefore doesn't send any position data. In order to achieve this, the device needs to be set into Operational Mode (☞ 10.2.5.1) and if necessary the sending cycle of the position data has to be adjusted (☞ 10.2.3.4).

10.2.3.2 Normal Mode

	<p>Note! The commands which are described in section 10.2.3.2 Normal Mode are only processed by the CANopen device in the Operational and Pre-Operational mode.</p>
---	--

10.2.3.3 Setting the Heartbeat Cycle Duration

A CANopen device sends the heartbeat cyclically. This message communicates the current Operating Mode to the other bus sharing units.

1. Change into the Operational or Pre-operational Mode, if necessary
2. The following illustration shows the CAN-message, which should be transmitted to the CANopen device and the following answer.

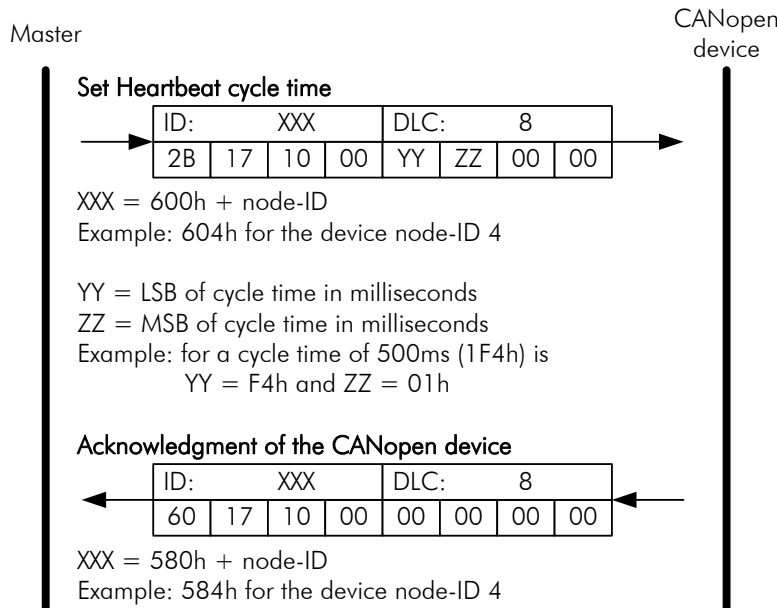

Figure 16: Setting the Heartbeat Cycle Duration

3. If the setting should be maintained in the case of a power failure, the changes have to be saved, as described in section ☞ 10.2.4.

10.2.3.4 Setting the Sending Cycle for the position data

The position data are sent cyclically by the device, therefore the device has to be in the Operational Mode (☞ 10.2.5.1)

The settings of the cycle duration takes place in the device profile DS406 in the object 1800h, Sub-index 5 and for devices with DS417 profile in object 1906h, Sub-index 5.

1. Change into the Operational or Pre-operational Mode, if necessary.
2. The following figure shows the CAN-message, which should be transmitted to the CANopen device and the following answer.

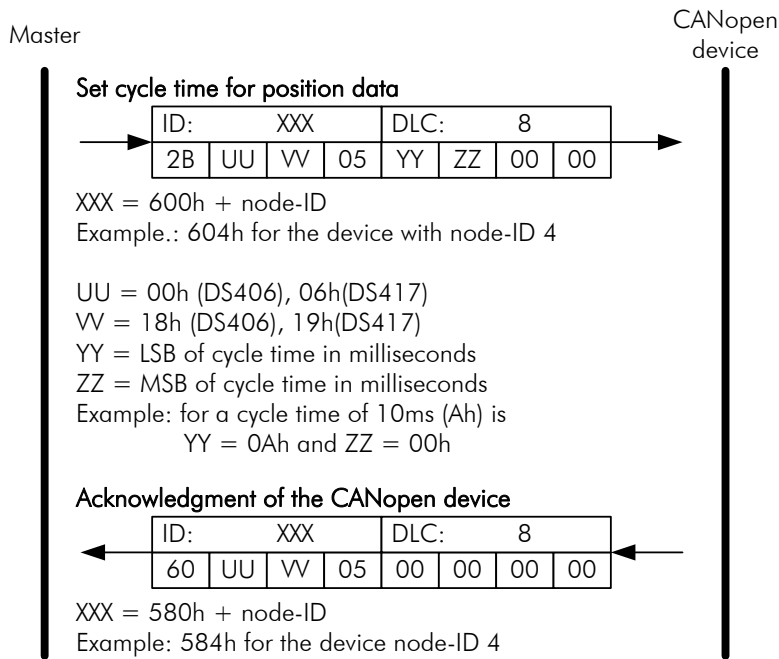

Figure 17: Setting the Sending Cycle for the position data

3. If the settings should be maintained in case of a power failure, the changes have to be saved, as described in section 10.2.4.

10.2.4 Saving the Parameters

In the normal case the settings are lost at power failure. In order to avoid this, they need to be saved according to the following procedure.

1. Change into the Operational or Pre-operational Mode, if necessary.
2. The following figure shows the CAN-message, which should be transmitted to the CANopen device and the following answer.

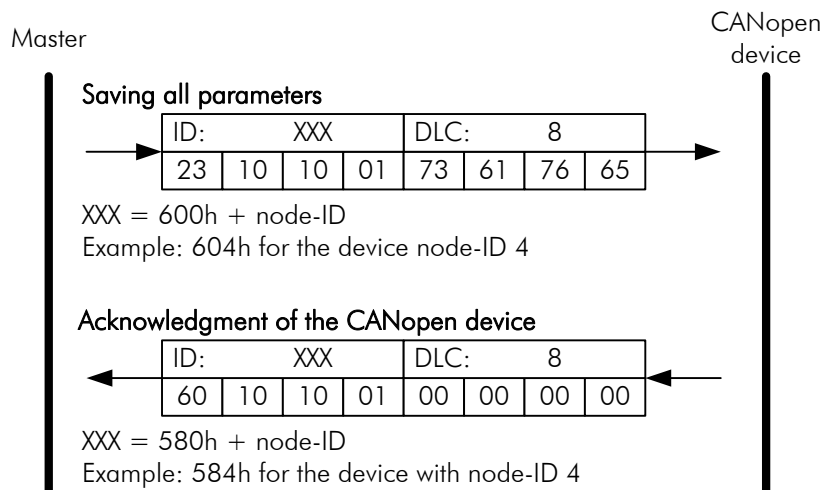

Figure 18: Saving the parameters

10.2.5 Changing the Operating Modes

10.2.5.1 Changing the device into the Operational Mode

In the Operational Mode the communication of the device is fully functional.

The following CAN-message causes the change of all CANopen participants into the Operational Mode.

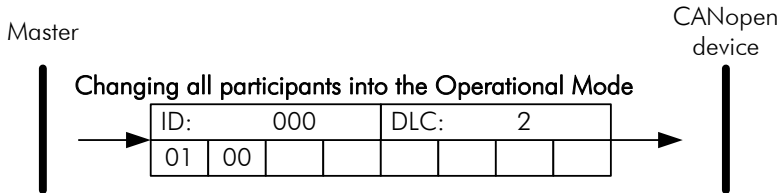

Figure 19: Changing the device into the Operational Mode

10.2.5.2 Changing the device into the Pre-operational Mode

In the Pre-operational Mode the communicating settings of the device are adjusted.

The following CAN-message causes the change of all CANopen participants into the Pre-Operational mode.

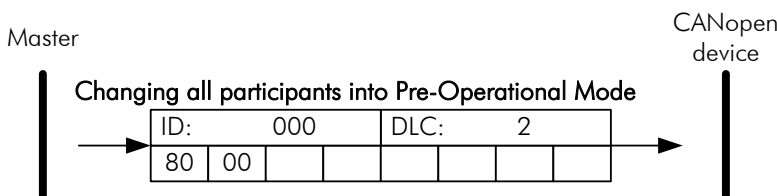

Figure 20: Changing the device into the Pre-operational Mode

10.2.5.3 Changing the device into the Stopped Mode

Bus sharing units in the Stopped Mode are passive participants. In this mode all the communication is turned off, except the monitoring activity (e.g. heartbeat).

The following CAN-message causes the change of all CANopen participants into the Stopped Mode.

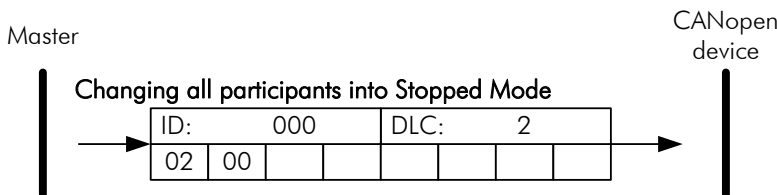



Figure 21: Changing the device into the Stopped Mode

10.2.6 LSS Configuration

Basic settings like node-ID and baud rate have to be adjusted with the Layer Setting Services (LSS).

10.2.6.1 Changing into the LSS Configuration Mode

In order to be able to change the Parameter (node-ID, bit rate), the device has to be changed into the LSS Configuration Mode.

	<p>ATTENTION!</p> <p>With the following command all the bus sharing units which are in the Stopped Mode are changed into the LSS Configuration Mode. Use this command, if only one device is connected to the bus, because other devices could be affected in their function.</p>
---	--

The following CAN-message causes the change into the LSS Configuration Mode.

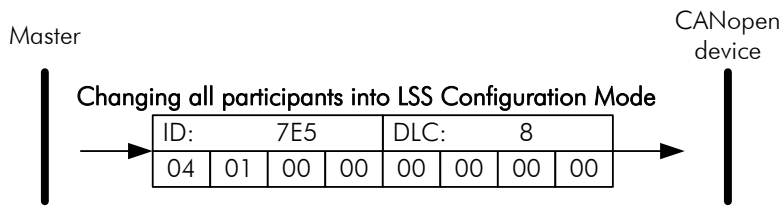

Figure 22: Changing into the LSS Configuration Mode

10.2.6.2 Saving the parameters in the LSS Mode

In order not to lose the changes in case of a power failure, they have to be saved in the non-volatile memory of the CANopen device.

The following figure shows the necessary message for this procedure.

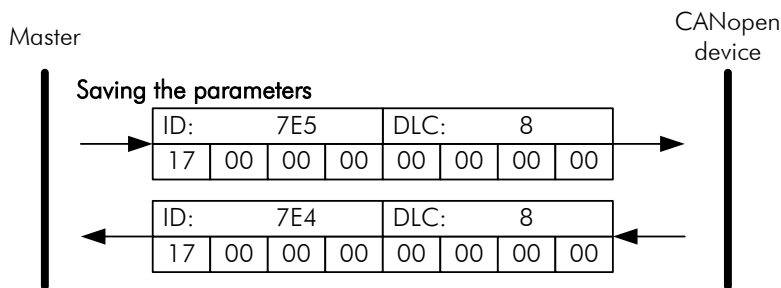

Figure 23: Saving the parameters in the LSS Mode



ATTENTION!

During the saving procedure the device is not accessible over a period of a few milliseconds.

10.2.7 Setting the Baud rate

1. Change the device into the Stopped mode (see section 10.2.5.3)
2. Change the device into the LSS Configuration Mode (see section 10.2.6.1)
3. Change baud rate according to the following command:

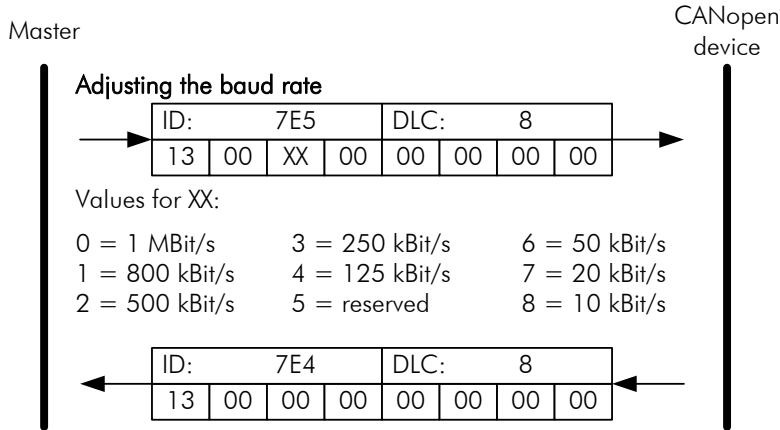

Figure 24: Setting the Baud rate

4. Save parameter as described in section 10.2.6.2.
5. Turn the device off and restart it again.

10.2.8 Setting the node-ID

1. Change the device into the Stopped Mode (see section 10.2.5.3)
2. Change the device into the LSS Configuration Mode (see section 10.2.6.1)
3. Change node-ID with the following message:

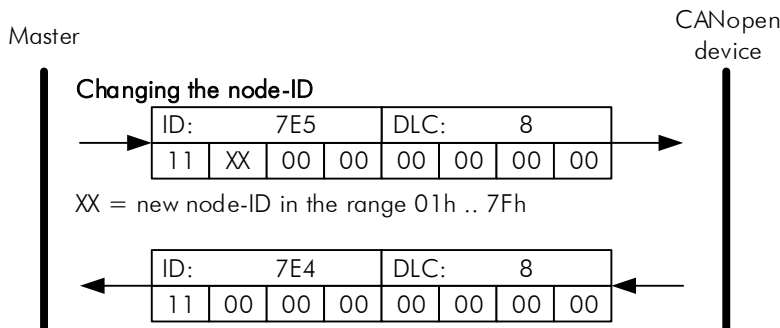

Figure 25: Setting the node-ID

4. Save parameter as described in section 10.2.6.2.
5. Turn the device off and restart it again.

10.3 SSI Interface

10.3.1 Function Principle

If the clock is not interrupted for the time $T_m - T/2$ (output of further 25 periods), the shift register clocks once again the same data value (error recognition in the evaluation). Some encoders contain a Power Failure Bit (PFB). Attention: With the LIMAX2M the PFB is always "LOW"!

10.3.2 Data Protocol

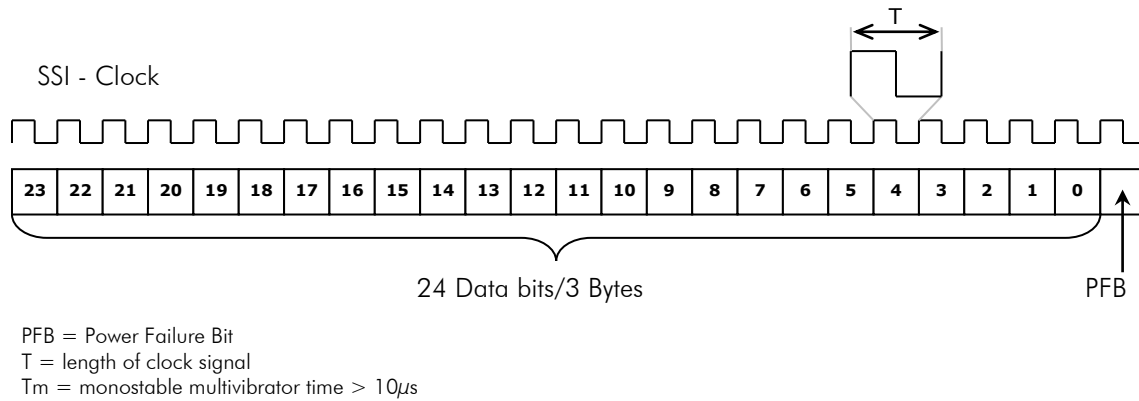

Figure 26: Data Protocol SSI

10.3.3 Pin Assignment SSI

Table 4: Pin Assignment SSI

8-pin M12 (male) connector	Colour	Function
1	White	0V / GND
2	Brown	+24 VDC
3	Green	SSI_CLK+
4	Yellow	SSI_CLK-
5	Grey	SSI_DATA+
6	Pink	SSI_DATA-
7	Blue	N.C.
8	Red	N.C.
Housing	Blank	Cable shield

10.4 RS422 and RS485* Interface

*) Attention: RS485 only unidirectional

If the measuring system is equipped with an RS422 or RS485 interface, the data communication has the following format:

- 9600 bit/s baud (other bitrates on request)
- 1 Start bit
- 8 data bits
- 1 stop bit
- no parity

10.4.1 Data Protocol

The measured absolute position will be represented in the three ABS-position data bytes.

Version 4221

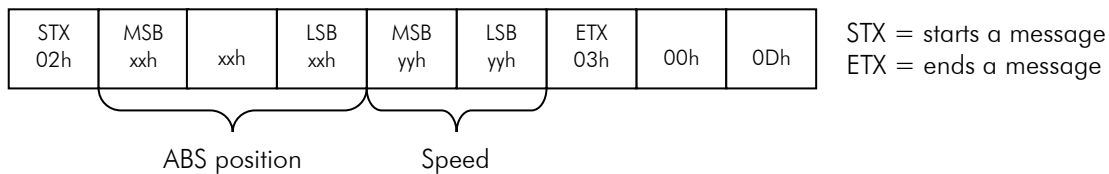

Figure 27: Data Protocol Version 4221

Versions 4220 / 4850

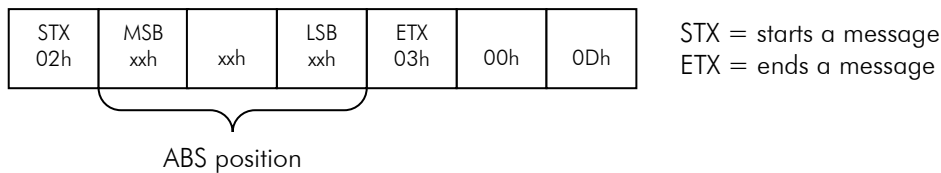

Figure 28: Data Protocol Versions 4220 / 4850

10.4.2 Command Descriptions

Important:

Before you send a new message to the LIMAX2M wait for the answer first. After allocating a new address the LIMAX2M answers in max. 0.5 seconds. In other cases it even in a few milliseconds. After this time it is not expected to get an answer (transmission error).

10.4.2.1 Principle Format of Message



- STX = starts a message
 - ETX = ends a message
 - Check Byte = contains the arithmetic checksum of STX, byte 1 and byte 2.
- The meaning of bytes 1 to 4 can be found in the following chapters.

10.4.2.2 Position request of LIMAX2M with the address "i"

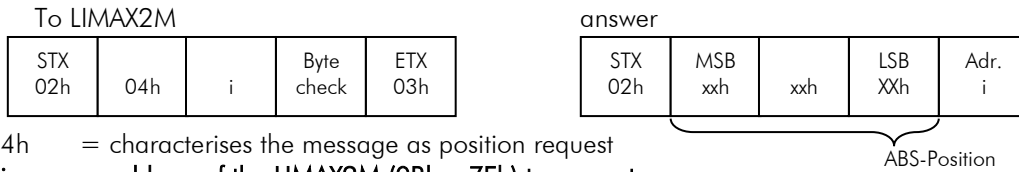

04h = characterises the message as position request
 i = address of the LIMAX2M (0Bh – 7Fh) to request
 Position values are always smaller than FFFF00h

10.4.2.3 A LIMAX2M address request

Attach in each case only one LIMAX2M e.g. over a RS422 converter to the serial interface (COM-port) of a PC.



05h = characterizes a message as address request
 i = LIMAX2M address
 FFh FFh does not occur immediately after STX with position inquires as answer!
 In this case (0Bh <= i <= 7Fh) this is the answer of the address request.

10.4.2.4 Allocation of an LIMAX2M address

Attach in each case only one LIMAX2M e.g. over a RS422 converter to the serial interface (COM-port) of a PC.



06h = characterizes a message as address allocation
 i = the new LIMAX2M address. Important: At the answer you get the new address + 80h.

The addresses 80 h – FFh as well as 00 h – 0 Ah are FORBIDDEN. If you try to assign an address smaller than eight, LIMAX2M gives you a "negative answer" and keeps its former address.

10.4.2.5 Error Messages

If one of the described operations failed for some reason LIMAX2M gives an error message with a respective error-code.

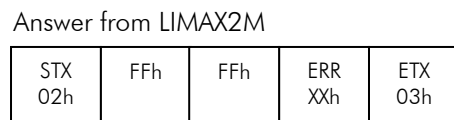

ERR = Error-Code (04h – 0Ah) error – codes are listed at the next page.

Table 5: Error-codes of an addressable LIMAX2M

Code	Meaning
04h	Wrong sequence of bytes sent to LIMAX2M, for example if 4. Byte after STX is no ETX or the Byte after STX is not 0x04, 0x05 or 0x06.
05h	Receiving Error / Interface Error (for example if a message with a wrong baud rate was sent etc.)
06h	Invalid LIMAX2M address: appears after trying to assign an address smaller 0Bh or bigger 7Fh to LIMAX2M.
07h	LIMAX2M has lost its address: internal check of X redundantly stored address of LIMAX2M has failed. This message is sent at power up immediately if an error in reading EEPROM is detected or if the internal address error cannot be fixed.
08h	Internal EEPROM storage error.
09h	Error in transmission of position (no tape, tape damaged or distance between tape and sensor head too big).
0Ah	Check-Sum-Error: Check-sum of a message sent to LIMAX2M is wrong.

10.4.2.6 Connection to a RS422 Master

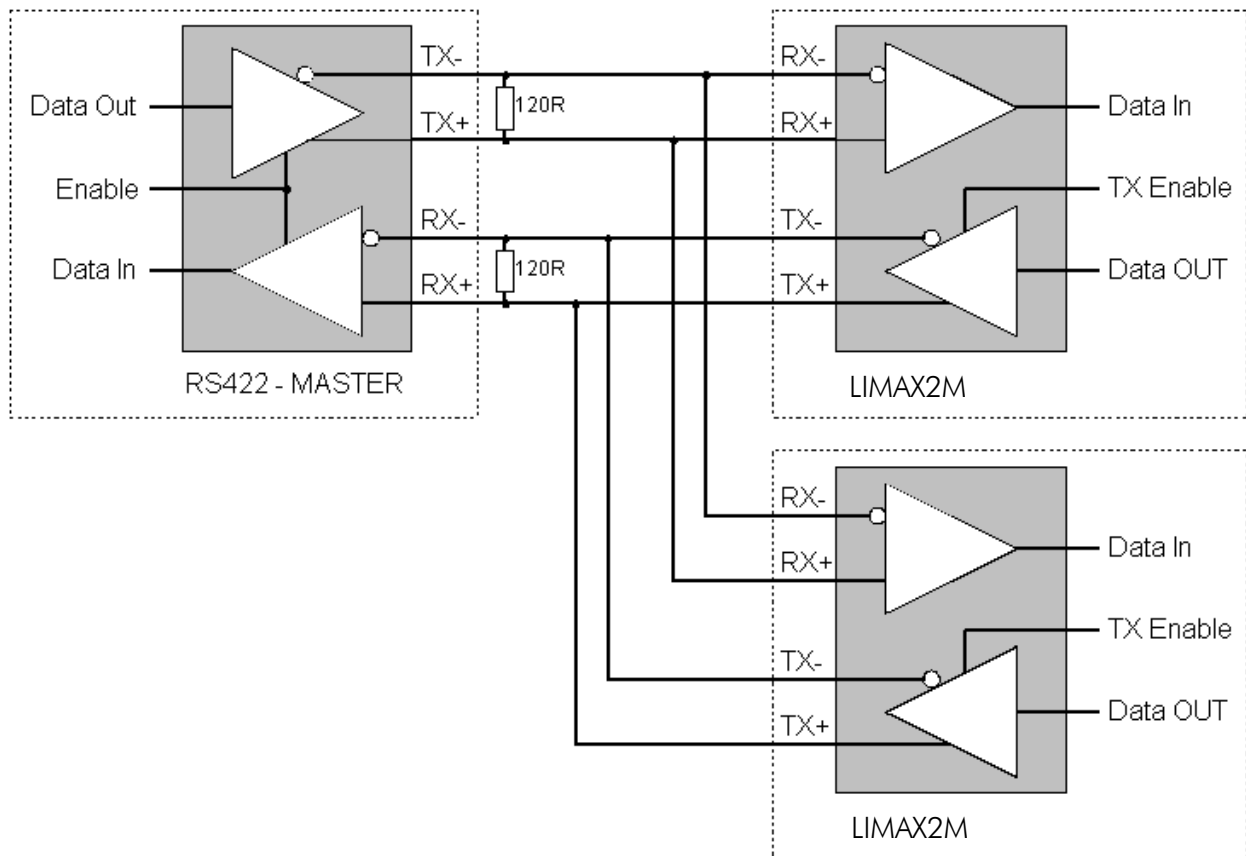

Figure 29: Connection to a RS422 Master

10.4.3 Pin Assignment RS422

Table 6: Pin Assignment RS422

8-pin M12 (male) connector	Colour	Function
1	White	0V / GND
2	Brown	+24 VDC
3	Green	RS422_RX+
4	Yellow	RS422_RX-
5	Grey	RS422_TX+
6	Pink	RS422_TX-
7	Blue	N.C.
8	Red	N.C.
Housing	Blank	Cable shield

10.4.4 Pin Assignment RS485

Table 7: Pin Assignment RS485

5-pin M12 (male) connector	Colour	Function
1	Brown	+24 VDC
2	White	0V / GND
3	Blue	RS485_A
4	Black	RS485_B
5	Grey	N.C.
Housing	Blank	Cable shield

11 Disturbances, Maintenance, Cleaning

This chapter describes possible causes for disturbances and measures for their removal. In case of increased disturbances, please follow the measures for fault clearance in chapter 11.1. In case of disturbances that cannot be eliminated by following the advice and the fault clearance measures given here, please contact the manufacturer (see second page).

11.1 Fault Clearance



CAUTION!

The device, the connection line and the signal cable must not be installed next to sources of interference that emit strong inductive or capacitive interference or strong electrostatic fields.

External perturbations can be avoided through suitable cable routing.



The screen of the signal output cable should only be connected to the following circuit on one side. The screens should not be grounded on both sides. Signal cables always have to be routed separately from the load power line. A safety distance of at least 0,5 m has to be kept from inductive and capacitive sources of interference such as contactors, relays, motors, switching power supplies, clocked controllers etc.!

If interferences occur in spite of all the items stated above being observed, please proceed as follows:

1. Installation of RC-circuits via contactor coils of AC-contactors (e.g. 0,1 μ F / 100 Ω)
2. Installation of recovery diodes via DC-inductors
3. Installation of RC-circuits via the different motor phases (in the terminal box of the motor)
4. Do not connect protective earth and ground
5. Connect a mains filter ahead of the external power pack

11.2 Re-start after Fault Clearance

After the fault clearance:

1. Reset the emergency stop mechanism if necessary
2. Reset the error report at the super-ordinate system if necessary.
3. Ensure that there are no persons in the danger area.
4. Follow the instructions from chapter 9.



WARNING!

Danger of injury through non-conventional fault clearance!

Non-conventional fault clearance can lead to severe injuries and damage of property.

Therefore:

- Any work to clear the faults may only be performed by sufficiently qualified staff
- Arrange enough space before starting the works
- Make sure that the mounting area is clean and tidy. Loose components and tools are sources of accidents.

If components need to be replaced:

- Pay attention to a correct installation of the spare parts.
- Reinstall all the fixing elements properly
- Before turning on the device, ensure that all covers and safety equipment is installed correctly and functions properly

11.3 Maintenance

The device is maintenance-free.



WARNING!

Danger through non-conventional maintenance!

Non-conventional maintenance can lead to severe injuries and damage of property.

Therefore:

Maintenance works may only be completed by staff that has been authorized and trained by the operator.

11.4 Cleaning



WARNING!

The device can only be cleaned with a damp cloth, do not use aggressive cleanser!

12 Type Designation

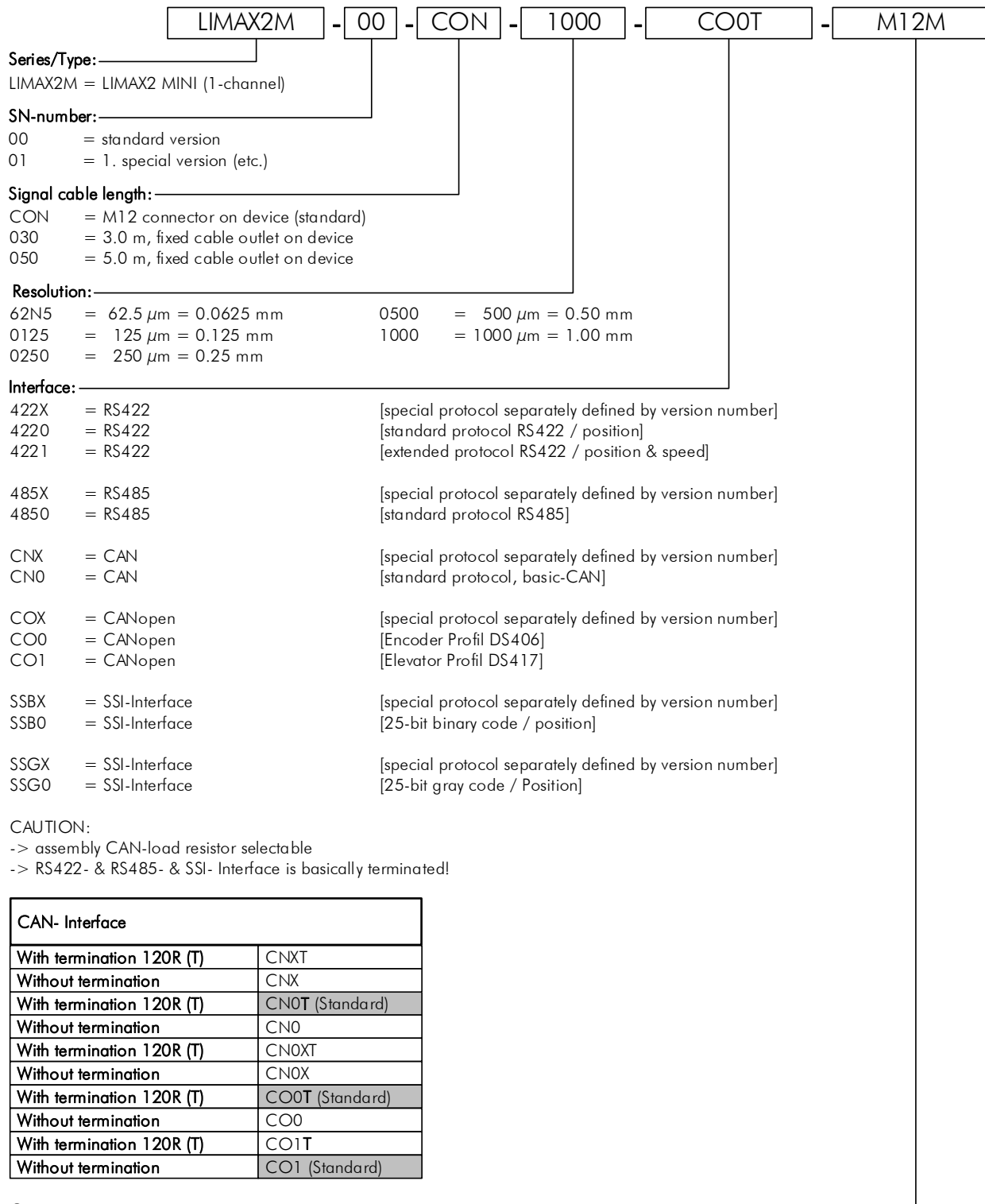

Connection options: _____

M12M = 5(8)-pin M12-round plug [number of poles or assignment depend on the chosen interface]

(Others on request)

Example	Designation
LIMAX2M-00-CON-1000-CO0T-M12M	M12-Male plug on device

12.1 Accessories

Order Designation	Description
AB20-80-10-1-R-D-15-BK80	Magnetic tape for series LIMAX2M
Guidance LIMAX2M complete	Set with guide rail with underlay and holding plate with screw
LIMAX RMS	Installation kit <ul style="list-style-type: none"> For centrally guided lift cars
LIMAX RMS 90	Installation kit <ul style="list-style-type: none"> Angled for cabins with rucksack layout
LIMAX S-RMS	Installation kit <ul style="list-style-type: none"> With safety position switch

12.1.1 Cable [CAN / RS485- Interface]

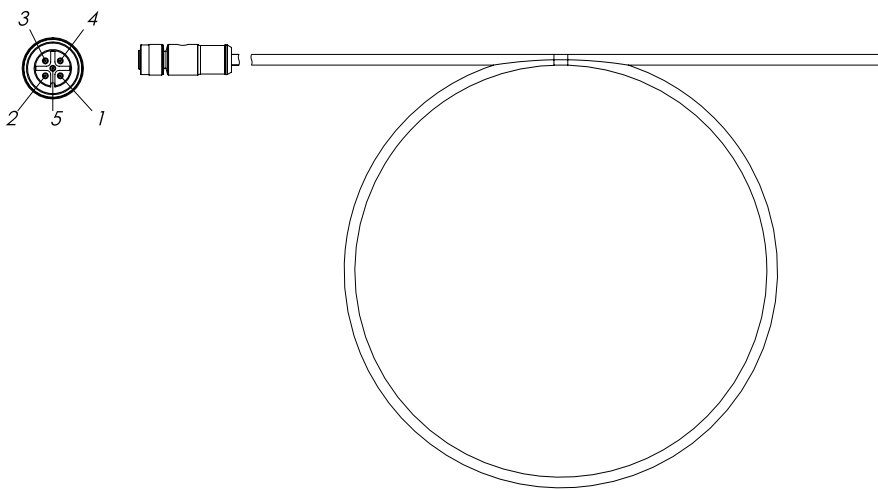

Figure 30: Cable M12F5 - open cable ends

Table 8: Connections Cable M12F5 - open cable ends

M12F5	Color	Function CAN	Function RS485
1	Brown	N.C.	+24 VDC
2	White	+24 VDC	0 V / GND
3	Blue	0 V / GND	RS485 A
4	Black	CAN H	RS485 B
5	Grey	CAN L	N.C.
Chassis	Blank	Cable shield	Cable shield

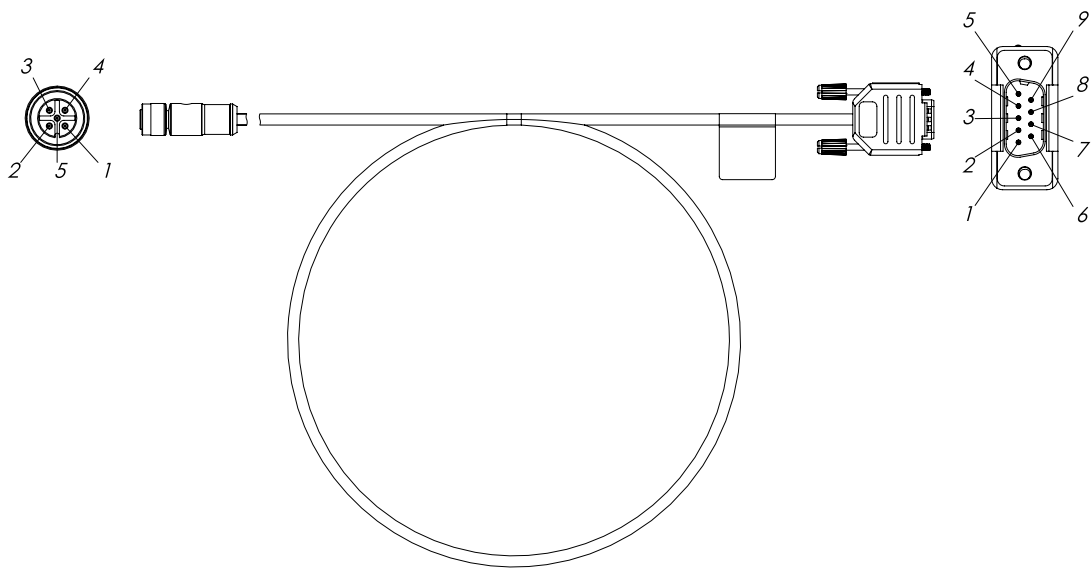

Figure 31: Cable M12F5 - D9M

Table 9: Connections Cable M12F5 - open cable ends

M12F5	D9M	CAN	Function
1	-	Brown	N.C.
2	9	White	+24 VDC
3	6	Blue	0 V / GND
4	7	Black	CAN H
5	2	Grey	CAN L
Chassis	Chassis	Cable shield	Cable shield

Order Designation	Description
CABLE-LIMAX2M-M12F5-XX.X	Device side Control side CAN & RS 485 Assignment open cable ends
CABLE-LIMAX2M-M12F5-XX.X-D9M	Device side Control side CAN & CANopen Assignment 9-pin D-SUB plug

*XX.X = cable length

12.1.2 Cable [SSI- / RS422- Interface]

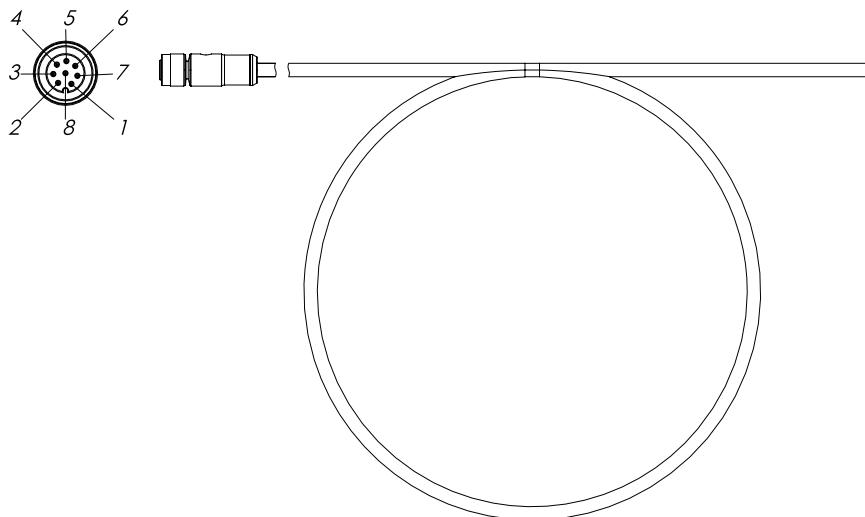

Figure 32: Cable M12F - open cable ends

Table 10: Connections Cable M12F - open cable ends

M12F8	Color	SSI Function	RS422 Function
1	White	0 V / GND	0 V / GND
2	Brown	+24 VDC	+24 VDC
3	Green	SSI_CLK+	RS422_RX+
4	Yellow	SSI_CLK-	RS422_RX-
5	Grey	SSI_DATA+	RS422_TX+
6	Pink	SSI_DATA-	RS422_TX-
7	Blue	N.C.	N.C.
8	Red	N.C.	N.C.
Chassis	Blank	Cable shield	Cable shield

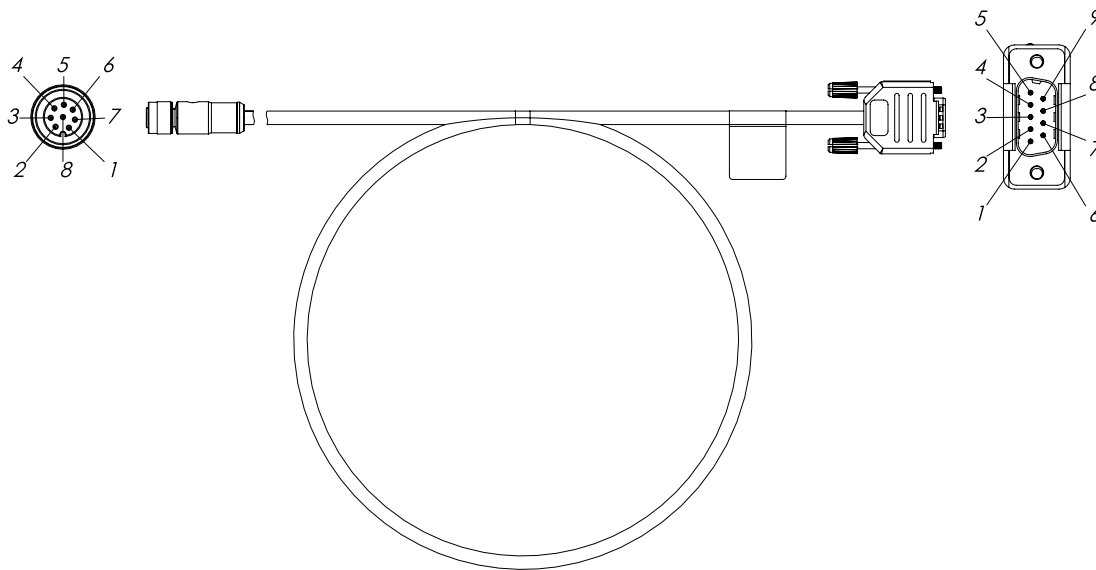

Figure 33: Cable M12F - D9M1

Table 11: Connections M12F - D9M1

M12F8	D9M1	Color	SSI Function
1	1 & 5	White	0 V / GND
2	6	Brown	+24 VDC
3	2	Green	SSI_CLK+
4	7	Yellow	SSI_CLK-
5	4	Grey	SSI_DATA+
6	8	Pink	SSI_DATA-
7	-	-	-
8	-	-	-
-	9	-	-

Order Designation	Description
CABLE-LIMAX2M-M12F8-XX.X	Device side Control side CAN & RS 422 Assignment open cable ends
CABLE-LIMAX2M-M12F8-XX.X-D9M1	Device side Control side CAN & CANopen Assignment 9-pin D-SUB plug

*XX.X = cable length

12.1.3 Mounting Angle

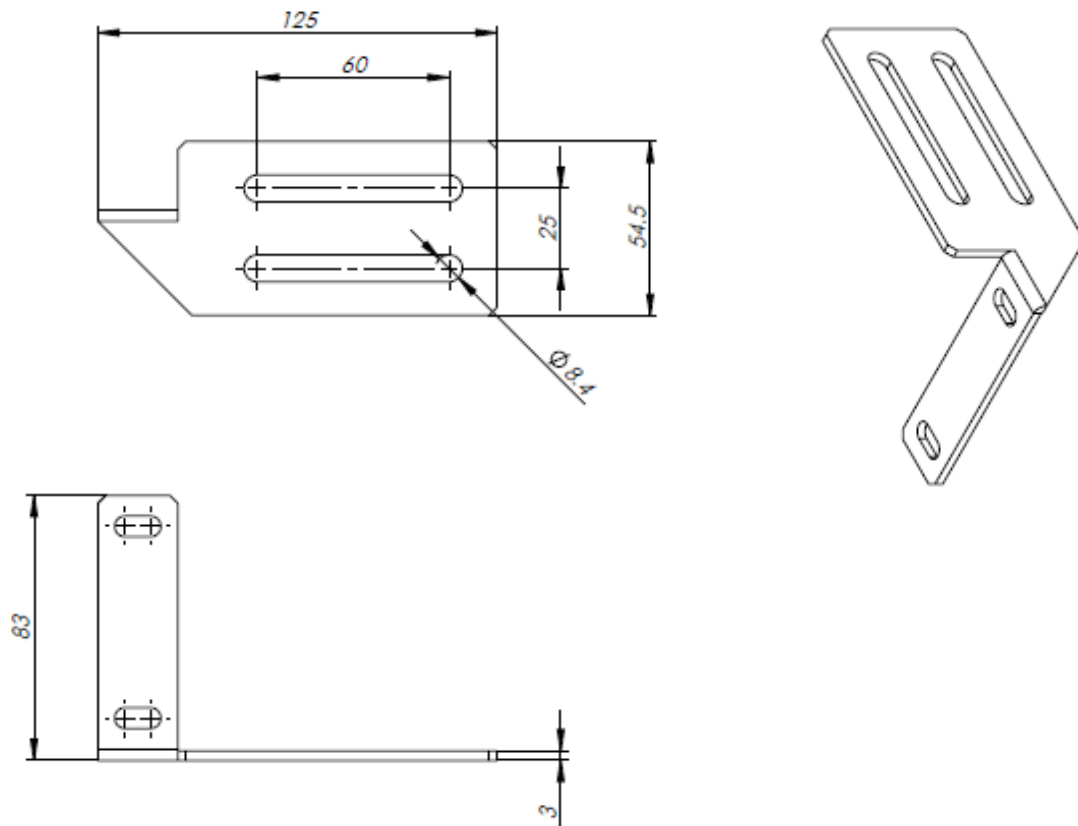

Figure 34: Mounting angle

Order Designation	Description
LIMAX02-M MW	Mounting angle for LIMAX02-M

Notes:

Notes:

13 Index

Accident prevention regulations.....	5	Magnetic Tape Structure	13
CAN Interface and Protocols.....	23	Maintenance.....	34, 35
Causes of risk.....	7	Operating area	14
Changing the Operating Modes	26	Operational safety.....	5
Cleaning.....	34, 35	Order reference	11
Connections	22	Packaging material.....	9
Conventional use.....	8	Protection against contact	14
Demounting	6	Protective equipment	7
Device number	11	RS 422 Interface	30
Dimensions Magnetic Tape.....	12	Safety	5, 7
Dimensions Sensor.....	11	Safety instructions	5
Disposal.....	6	Safety rules	5
Disturbances	34	Sensor construction	10
Explanation of symbols.....	5	SSI Interface.....	29
Fault clearance.....	34	Start-up	14
First start-up	14	Statement of warranties.....	6
Identification	11	Storage	9
Installation	14	Technical Data Magnetic Tape	13
Installation of the Sensor	16	Technical Data Sensor	12
Interfaces	22	Transport	9
LED status notice	22	Transport damage.....	9

Document- No.: D-103918 / Rev. 2
Document- Name : LIMAX2M-00-MA-E_06-20
Subject to change - © 2020
ELGO Batscale AG

ELGO Batscale AG
Measuring | Positioning | Control
Föhrenweg 20, FL-9496 Balzers
Fon.: +423 (0) 380 02 22, Fax.: +423 (0) 380 02 24
Internet: www.elgo.li, Mail: info@elgo.li

