

Operation Manual

SERIES Z17

Battery powered Length measuring System

Predestined for the mobile assembly on manual sledges, carriage and back stop systems



- 12 months in continuous operation*)
- Including sensor for magnetic length measuring system
- Simple operation and assembly
- LCD-Display with integrated battery status
- No wiring is necessary
- Possibility of fraction display in the INCH mode

1. General Information.....	3
1.1. Information Operation Manual.....	3
1.2. Explanation of Symbols.....	3
1.3. Statement of Warranties.....	4
1.4. Demounting and Disposal.....	5
2. Safety.....	6
2.1. General Cause of Risks.....	6
2.2. Personal Protective Equipment.....	6
2.3. Conventional Use.....	7
3. Transport and Storage.....	7
3.1. Safety Instructions for Transport/Unpacking and Loading.....	7
3.2. Handling of Packaging Material.....	7
3.3. Check of Transport.....	8
3.4. Storage.....	8
4. Product Features.....	9
5. Technical Data.....	10
5.1. Dimensions.....	10
5.1.1 Dimensions Indicator.....	10
5.1.2 Dimensions Sensor.....	10
5.1.3 Accessories.....	11
5.1.3.1 FS 20.25 guide rail and FW 20.60 guide carriage.....	11
5.2 Technical Data.....	12
6. Installation.....	13
6.1. Qualifications of the Staff.....	13
6.2 The Sensor.....	13
6.3 Mounting.....	13
7. Structure and Function.....	14
7.1 Arrangement of the LCD-Display.....	14
7.2 Selecting parameters and input.....	15
7.2.1 Parameter level activate.....	15
7.2.2 Accessing the Decade.....	15
7.2.3 Change the value.....	15
7.2.4 Leaving Parameter level.....	15
7.2.5 Parameters.....	16
7.3 Functions in Normal mode.....	17
7.3.1 Set datum value.....	17
7.3.2 Switching incremental / absolute.....	17
7.4 Accessories.....	18
7.4.1 Magnetic tape.....	18
8 Interferences.....	19
8.1 Security.....	19
8.2 Electrical interference suppression.....	20
8.3 Restart after fault clearance.....	20
8.4 EMC information.....	21
9 Maintenance.....	21
9.1 Battery changing.....	21
10 Type Designation.....	22
11 Accessories.....	22
12 Register.....	23
12.1 Index.....	23

1. General Information

1.1. Information Operation Manual

The manual contains important information regarding the handling of the indicator. Precondition for safe operation is the compliance with the specified safety and handling instructions. Moreover, observe the existing local accident prevention regulation and general safety rules.

Please read the operation manual carefully before starting to work. The manual should be kept accessible at anytime. The illustrations in the manual are for better representation of the facts they are not necessarily to scale and can be slightly different to the actual construction.

1.2. Explanation of Symbols

Warning notices

Warning notices are characterised by symbols in the operation manual. The notes will be introduced by signal words to express the magnitude of the danger.

Follow these advices in order to avoid accidents and injuries to persons and property.



DANGER!

... adverts to direct dangerous situations that can lead to death or severe injuries.



CAUTION!

... advices to potentially dangerous situations that can lead to death or severe injuries.



ATTANTION!

... advices to potentially dangerous situations that can lead to damages on property.

Hints and commendations

**ADVERT!**

...highlights helpful hints and recommendations for efficient and failure-free operation.

Specific safety instructions

The following symbols in conjunction with safety instructions are used in order to point out possible hazards:

**DANGER!**

...marks perilous situations by electricity. By non-observance of the safety instructions the possibilities of death or severe injuries exist. The operations have to be carried out only by an electrician.

1.3. Statement of Warranties

The warranty conditions are in a separate document.

Guarantee

The producer guarantees the functional capability of the process engineering and the selected parameter. The period of warranty is one year and begins with the date of delivery.

1.4. Demounting and Disposal

Unless otherwise authorized, dispose the item considering the safety instructions.

Before demounting

- Disconnect the power supply
- Secure against re-start
- Disconnect supply lines physically and discharge remaining energy
- Dispose operating supplies with respect to the environment

Disposal

Recycle the decomposed elements:

- Scrap metal elements
- Recycle plastic parts
- Dispose the rest of the components according to their material consistence



ATTENTION!

Wrong disposal → damage caused to the environment!

Electronic waste, electronic components, lubricants and operating supplies are liable to treatment of hazardous waste.

Only approved specialized companies should perform disposal.

Local authorities and waste management facilities provide information about environmentally suitable disposal.

2. Safety

2.1. General Cause of Risks

This chapter gives an overview about all important safety aspects to guarantee an optimal protection of employees.

Non-observance of the instructions mentioned in this operation manual can result in hazardous situations.

2.2. Personal Protective Equipment

Employees should wear protective clothing during installation of the device to minimize the risk of accidents.

Therefore:

Change into protective clothing before beginning the work process. Also observe any labels in the operating area regarding protective clothing.

Protective clothing



Safety working clothing

- ... is close-fitting
- ... is tear proof
- ... has tight sleeves without distant parts

Also wear no rings, necklaces or other jewellery.



Protective gloves

- ... for protecting the hands against abrasion and cuts

2.3. Conventional Use

The indicator **Z17** is for the limited purpose as described in this manual:

The indicator **Z17** is constructed for measurement uses only.



CAUTION!

Danger through non-conventional use!

Non-intended use and non-observance of this operation manual can lead to dangerous situations.

Therefore:

- Use **Z17** only as described
- Strictly follow this manual

Avoid in particular:

Remodelling, refitting or changing of the device or parts of it with the intention to alter functionality or scope of the position indicator.

ELGO is not liable for any damages resulting from improper use of the product.

3. Transport and Storage

3.1. Safety Instructions for Transport/Unpacking and Loading



ATTENTION!

Professional transport only.

Do not throw, hit or fold the package.

3.2. Handling of Packaging Material

Adverts for proper disposal refer to 1.4.

3.3. Check of Transport

Examine delivery immediately after receiving for completeness and transport damages.

In case of externally recognizable transport damages:

- Do not accept the delivery or do accept under reserve
- Note extent of damages on the transportation documents or on the delivery note
- File complaint immediately

**ADVERT!**

Claim any damages you recognize as soon as possible. The claims for damage must be filed in the lawful reclaim periods.

3.4. Storage

Store device only under following conditions:

- Do not store outside
- Keep dry and dust-free
- Do not expose to aggressive media
- Protect from direct sun light
- Avoid mechanical shocks
- Storage temperature: 20 to + 50 °C
- Relative humidity: 60% non-condensing
- Inspect packages regularly if stored for an extensive period of time (> 3 months)

4. Product Features

Z17 battery operated length measuring system

The systems Z17 consist of a magnetic sensor, which is fix connected to a display unit over a tug chain suitable cable (length 0.1... 1 m). Therefore no wiring or connectors are necessary when installing. Z17 is specially designed for the assembly on manual stop systems or on moving slide and gauge systems as there is no cable to be carried on.

For measuring a magnetic tape (ELGO MB 20.25 = 2.5 mm pole diversion) is attached alongside to the measuring distance, which delivers the necessary electrical Information (current position).

The sensor head resists to any kind of dust, dirt and water-jet and is absolutely abrasion resistant. Its protection class is IP 67.

The display unit possesses large programming possibilities (pulse scaling factor, decimal places, counting direction, incremental measurement and set function, adjustable reference value as well as a switch over for mm or inch operation).

The battery case is located at the rear side of the indicator. Due to its economical LCD display Z17 is able to work in permanent operation up to one year, a good battery quality preconditioned. Datas and parameters (except actual value) remain in case of changing battery.

5. Technical Data

5.1. Dimensions

5.1.1 Dimensions Indicator

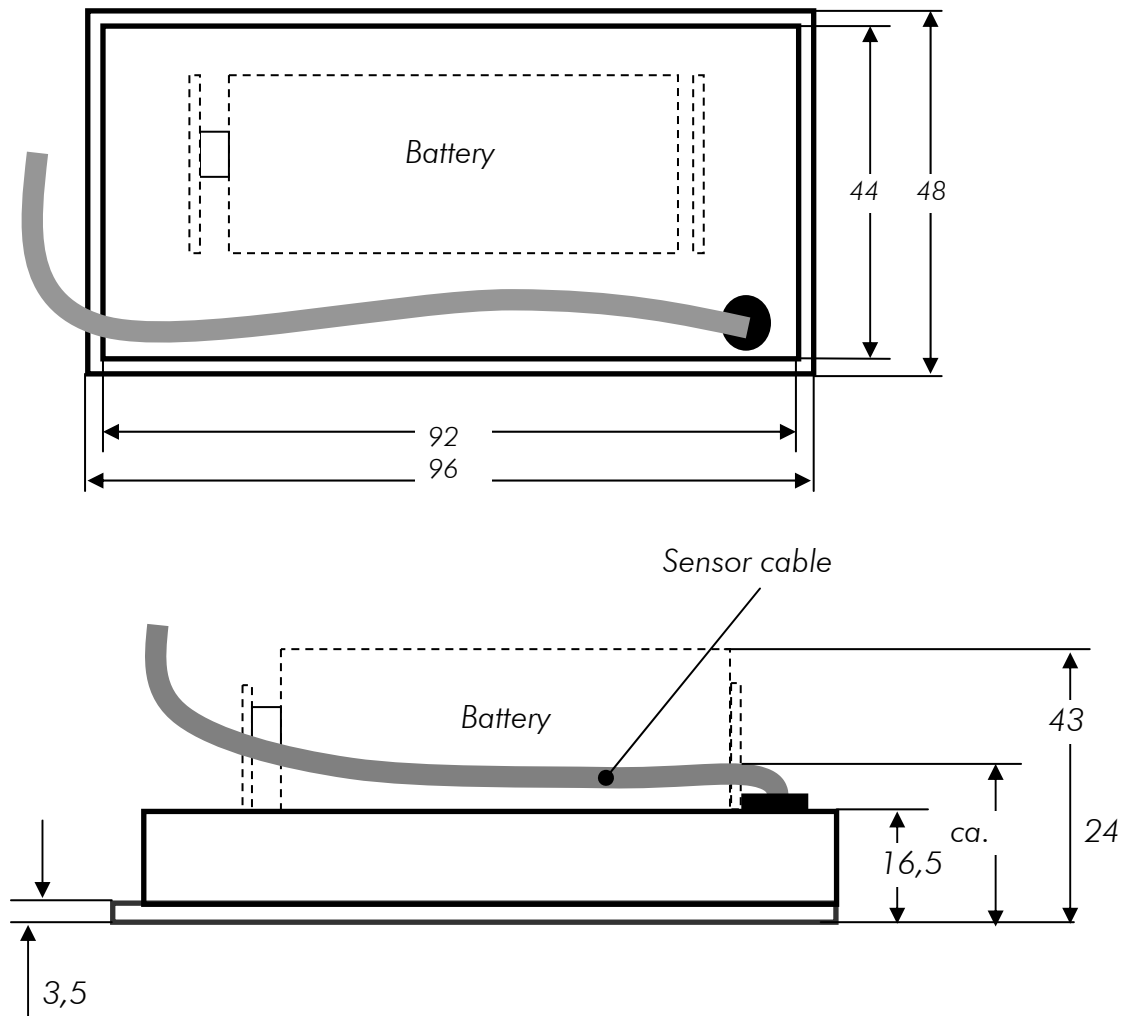

5.1.2 Dimensions Sensor

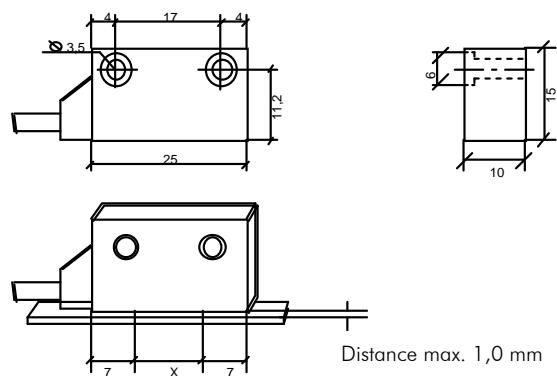

5.1.3 Accessories

5.1.3.1 FS 20.25 guide rail and FW 20.60 guide carriage

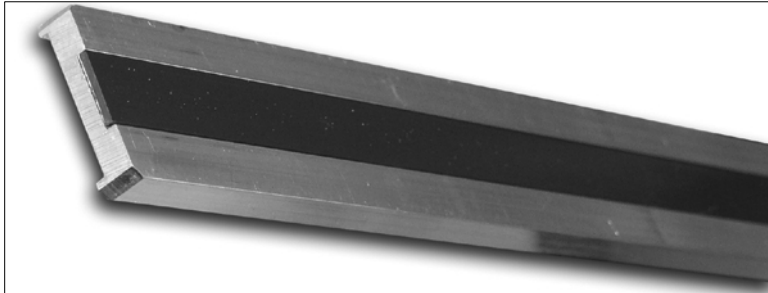

Rail: l x w x h = (1 or 2m) x 25 x 6mm

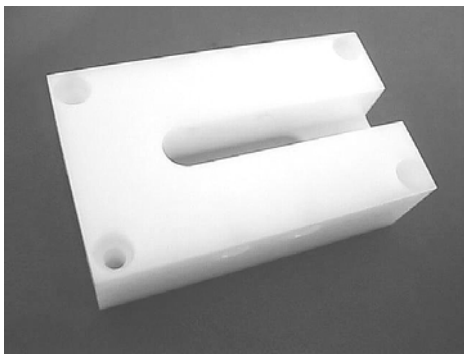

Carriage: l x w x h = 80 x 48 x 25mm

The guide rail F520.25 is an aluminium profile with integrated chase in which the magnetic tape is pasted. Additionally the matching guide carriage FW20.60 made of rubber which allows to slip.

5.2 Technical Data

Display Z17

LCD-Display	7 Decades (Digit height 11mm) Status of Battery and Unit
Power supply	1 x Battery (1,5 V)
Consumption with encoder	< 1 mA at 1,5 V
Operation temperature	+5 ° up to + 50 ° C
Drive speed	max. 2,5 m/sec
Housing	Material: Metal, black
Housing dimensions	W x H = 96 x 48 mm
Installation depth	40 mm (incl. cable)
Front panel outbreak	W x H = 92 x 44 mm
Protection class	IP 43 (installed)

Magnetic Sensor MS20.25

Sensor cable length	0,1 m up to max. 2,0 m (more on request)
Resolution	0,1mm
Protection class	IP66 Zinc die cast
Operation temperature	+5° up to + 50° C
min. Radius to bend	min. 60 mm
Distance Sensor/Tape	max. 1,0 mm (without cover tape „C“)

Magnetic Tape MB 20-25-10-1-R

Operation temperature	0° up to + 50°C
Accuracy at 20° C in mm	+/- (0,025 + 0,02 x L) L = effective Measuring length in m
Length expansion coefficient	$\alpha = 16 \times 10^{-6} \times 1/K$
Radius to bend	min. 150 mm

6. Installation

6.1. Qualifications of the Staff



Improper maintenance
... can lead to serious personal injuries or property
damage.

Therefore:
Maintenance work should be referred to qualified
and authorized by the operator and instructed
personnel.

6.2 The Sensor

The magnetically sensitive measuring resistance bridges are integrated in the sensor. From those the course-dependent metering pulses for the signal conditioning electronics are formed. The distance between the sensor and the tape within the measuring range X may not be larger than 1,0 mm. Every smaller value is permissible. The sensor cable has 6 cores and is high flexible. The cores are twisted pairs and screened. The sensor cable allows to be mounted on a chain moving carriage.

6.3 Mounting

For panel assembly, use the two mounting parts with drilled boreholes and the additionally grub screws (see image). The mounting parts and screws are included in delivery.

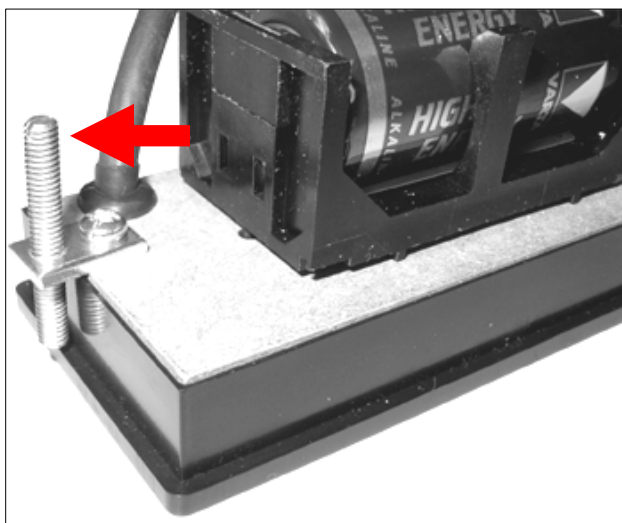

7. Structure and Function

7.1 Arrangement of the LCD-Display

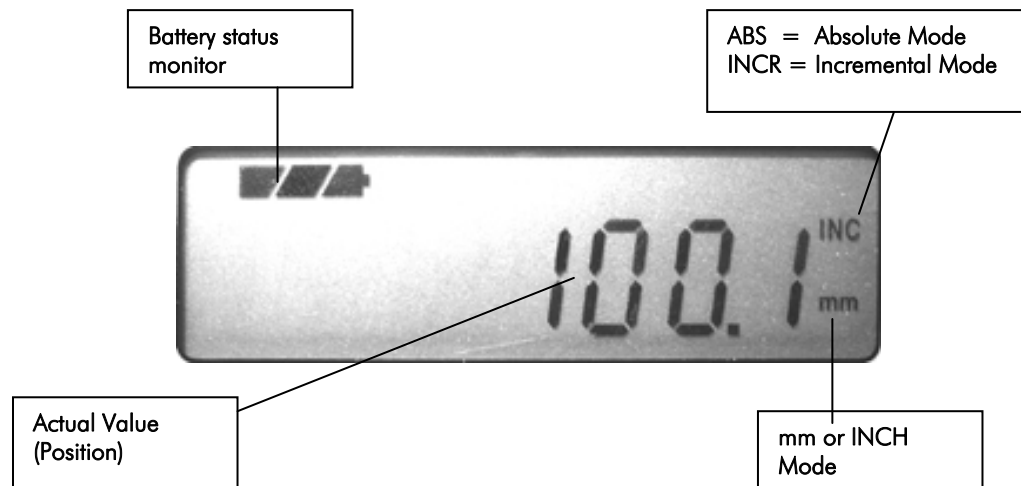

7.2 Selecting parameters and input

7.2.1 Parameter level activate

F For 3 seconds / 1 each x then press

With this key the parameter level will be activated. After about 3 seconds, the display shows "P 01" for the first parameter. When you press the button again, the parameter value can be changed. In that way all available parameters can be successive selected.

7.2.2 Accessing the Decade

Set 1x press

With this button the Decade will be forwarded at 1 point from the left to the right. The selected Decade is blinking.

7.2.3 Change the value

Incr/abs 1x press

With this button the value of the selected decade will be increased at 1 (0...9 or 0...1).

7.2.4 Leaving Parameter level

F Hold for 3 seconds in the parameter level

All parameters will be stored while leaving this level.

7.2.5 Parameters

Parameter	Description	Default Parameters
P01: AB	mm / inch Switching A = 0: mm – Mode A = 1: Inch – Mode (Resolution 0,001 Inch) Counting direction: B = 0: positive B = 1: negative	01
P03: A	Decimal point (0 ... 3)	1
P05: AB	Key lock: A: Button „ SET “ (0 = active / 1 = not active) B: Button „ Incr / Abs „ (0 = active / 1 = not active)	00
P08:	Multiplication factor (0,0001 ... 9,9999)	1,0000
P09:	Reference value(-999999,9 ... + 999999,9)	0,0
P99:	Displays the Firmware – Version	X.XX

7.3 Functions in Normal mode

7.3.1 Set datum value

F and **Set** 1x press together

With this key combination the actual value will be set to the reference value. (Only in the ABS-mode possible, if no offset level is activated.) The reference value is entered in parameter P09.

7.3.2 Switching incremental / absolute

incr/abs 1x press

With this key the unit switch from absolute mode to incremental mode: The display value is set to zero, and display the symbol "INC". Pressing the button again the display set again into absolute mode and "abs" is shown again.

7.4 Accessories

7.4.1 Magnetic tape

The magnetic tape MB 20-25-10-1-R

The magnetic tape consists of 3 components:

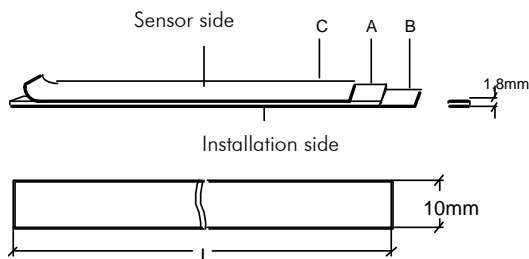

available lengths 0,5 - 32 m

- A The magnetic, high-flexible rubber tape on the bottom united with:
- B a magnetic flexible steel tape. This steel tape protects the rubber tape against mechanical defects and represents a magnetic short circuit simultaneously. This increases significantly the safety of function against extreme external magnetic influences. A and B are supplied united from the factory.
- C In order to receive the flexibility for transportation and assembly the third part also a steel tape (magnetically permeable) is supplied separately. It is used for the mechanical protection of the rubber tape and must be attached on the magnetic rubber tape after assembly.

8 Interferences

The following chapters describe possible causes for malfunction and the instructions to correct them. If you encounter problems check for proper installation first. Make sure that power is supplied to the system. If you observe recurring errors you might consider electrical interference suppression measures as described in section 7. If errors cannot be corrected with the following instructions please contact the manufacturer (see last page).

8.1 Security

Basics



CAUTION!
Risks of injury from improper fault clearances!

Improper fault clearances can cause serious personal or property damage.
Therefore:

- Fault clearance may only be carried out by qualified and instructed personnel
- Prior to the beginning of work provide sufficient room to assemble the equipment
- Please look for cleanliness at the place of installation; loosely around laying parts and tools are sources of accidents

If components have to be replaced:

- Look for correct installation of spare parts
- All mounting elements have to be assembled correctly
- Before resetting please ensure that all covers and protective devices are installed correctly and function properly

To ensure a perfect operation of the indicator the following (external) measures have to be taken additionally:

Place of installation:

The indicator should not be installed near to sources of interference generating strong inductive or capacitive interferences or strong electrostatic fields. Install the external power supply directly beside the indicator to avoid long low voltage wires.

8.2 Electrical interference suppression



Signal wires should be installed separately from load power lines and with a safe distance of at least 0.5 m to capacitive and inductive interferences such as contactors, relays, motors, switching power supplies, timed controllers.

If interferences occur in spite of applying all above mentioned measures proceed as follows:

1. Add RC elements over contactor coils of AC contactors (for example 0,1 μ F/100 Ω)
 2. Add recovery diodes over DC inductances
 3. Add RC elements over each drive phase (in connector box of the drive).
 4. Do not connect the GND potential with PE (earth potential)!
- Install a power filter before the external power supply

8.3 Restart after fault clearance

After fault clearance:

1. Reset emergency stop switch.
2. Quit disturbance on indicator.
3. Make sure that no person is located in the danger zone.
4. Start operating as explained in the instructions.

8.4 EMC information

A trouble-free operation of the control devices of the company ELGO Electric GmbH can only be guaranteed if in assembly, wiring and operating the following basic rules are observed and adhered to:

- use only shielded signal lines with a minimum diameter of 0.15 mm²
- to protect against electrical fields, connect the cable shield unilaterally, low resistance and low inductive with the operating lightning protection.
- unused arteries in signal lines should be isolated from each other separately
- isolate signal and power lines separately in long parallel lines (a distance of 300 mm is respected) therefore, should never be different voltage levels, e.g. 230V/50 Hz power supply and measuring signal 24V DC in one cable together
- low the emission by the Installation of filter networks in plants with frequency. In the operating instructions of the manufacturer FU find the appropriate instructions.
- wireless phones and Walky-talkies should never be used in the immediate vicinity of electronic devices

9 Maintenance

9.1 Battery changing

All data and parameters (except actual value) remains in case of changing battery (commercial 1.5 V battery, type "C").

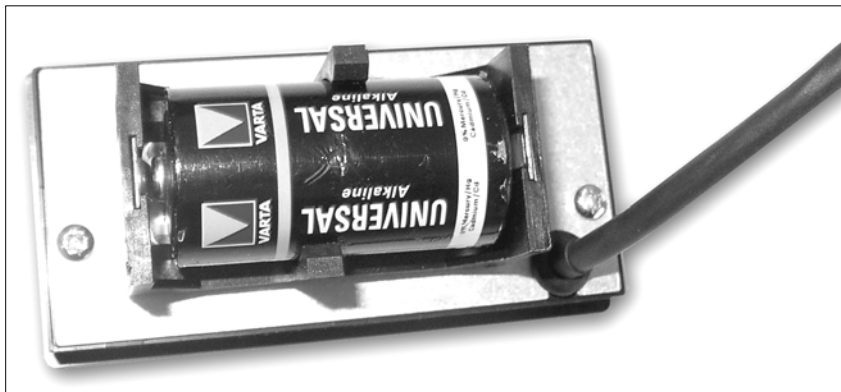

10 Type Designation

Z17 - 000 - 001 - XX.X - X

Series (Type)

Z17

SN-Nummer

000 = Standard

001 = 1st special version

Supply

001 = 1,5 V Battery

Sensor cable length

e.g. 02.0 = 2,0 meter

max. Length 2,0 meter

Options

N = without housing

11 Accessories

MB20-25-10-1-R

Magnetic tape MB 20-25-10-1-R:

Series

MB20 = incremental Magnetic tape

Pole pitching

25 = 2,5 mm

Band Width

10 = 10 mm

Tracks

1 = One track system

Tape construction

R = Standard: Magnetic tape on inference material

12 Register

12.1 Index

D	
Demounting	5
Dimensions	10
Disposal.....	5
E	
Enter the parameter	16
G	
Guarantee	4
I	
Interferences.....	19
L	
O	
Operation manual.....	3
M	
Maintenance	21
P	
Parameter	16
Protection clothing.....	6
Purpose of Use	7
R	
Reference value	17
S	
Security.....	6
Storage.....	8
Suppress interferences.....	20
Symbols	3
T	
Technical Data	12
Transport	8
Type Designation.....	21

