

Operating Manual

SERIES *EMIX2*

Magnetic Incremental Length Measuring System with 0.01 mm resolution

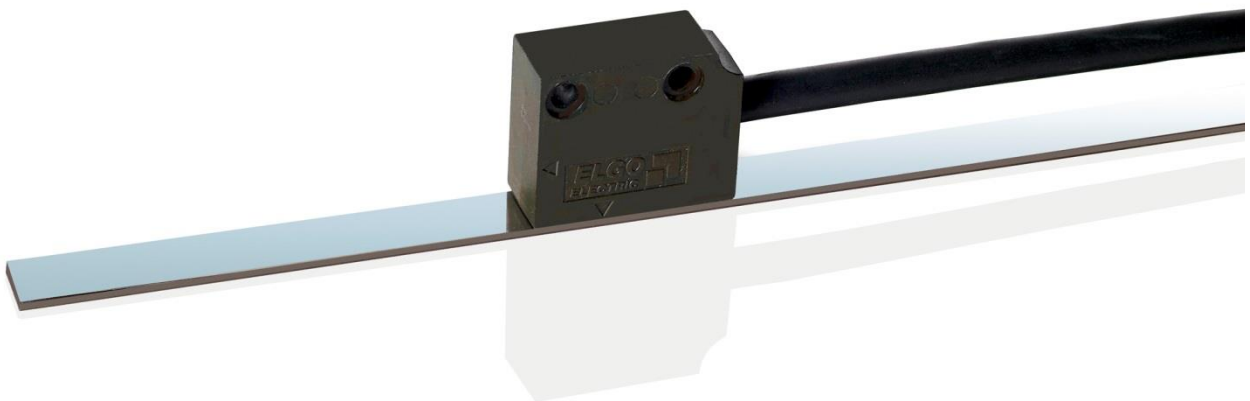

- Direct contact-free measurement
- Distance range between sensor and magnetic tape: 0.1 to 0.8 mm
- High resolution of 0.01 mm
- Repeat accuracy +/- 0.01 mm
- Very resistant against dirt

Publisher ELGO Electronic GmbH & Co. KG
Carl-Benz-Str. 1
D-78239 Rielasingen-Worblingen

Technical Support  +49 (0) 7731 9339 – 0
 +49 (0) 7731 2 13 11
 info@elgo.de

Document- No. 799000076

Document- Name EMIX2-000-MA-E_19-17

Document- Revision Rev. 4

Issue Date 2017-05-11

Copyright © 2017, ELGO Electronic GmbH & Co. KG

1 Contents

| | | |
|----------|--|-----------|
| 1 | Contents | 3 |
| 2 | General, Safety, Transport and Storage | 4 |
| 2.1 | Information Operating Manual | 4 |
| 2.2 | Explanation of Symbols | 4 |
| 2.3 | Statement of Warranties | 5 |
| 2.4 | Demounting and Disposal | 5 |
| 2.5 | General Causes of Risk..... | 5 |
| 2.6 | Personal Protective Equipment..... | 5 |
| 2.7 | Conventional Use | 6 |
| 2.8 | Safety Instructions for Transport, Unpacking and Loading | 6 |
| 2.9 | Handling of Packaging Material | 6 |
| 2.10 | Inspection of Transport | 6 |
| 2.11 | Storage | 6 |
| 3 | Product Features | 7 |
| 3.1 | Functional Principle..... | 7 |
| 3.2 | Pulse Diagram..... | 7 |
| 4 | Technical Data | 8 |
| 4.1 | Identification | 8 |
| 4.2 | Dimensions Sensor..... | 8 |
| 4.3 | Technical Data Sensor | 9 |
| 4.4 | Technical Data Magnetic Tape..... | 10 |
| 5 | Installation and First Start-Up..... | 11 |
| 5.1 | Operating Area | 11 |
| 5.2 | Installation of the Magnetic Tape..... | 12 |
| 5.3 | Installation of the Sensor | 15 |
| 6 | Connections..... | 17 |
| 6.1 | Pin Assignment | 17 |
| 7 | Disturbances, Maintenance, Cleaning..... | 18 |
| 7.1 | Fault Clearance..... | 18 |
| 7.2 | Re-start after Fault Clearance..... | 18 |
| 7.3 | Maintenance..... | 19 |
| 7.4 | Cleaning | 19 |
| 8 | Type Designation | 20 |
| 8.1 | Accessories | 20 |
| 9 | Index | 23 |

2 General, Safety, Transport and Storage

2.1 Information Operating Manual



This manual contains important information regarding the handling of the device. For your own safety and operational safety, please observe all safety warnings and instructions. Precondition for safe operation is the compliance with the specified safety and handling instructions. Moreover, the existing local accident prevention regulations and the general safety rules at the site of operation have to be observed.

Please read the operating manual carefully before starting to work with the device! It is part of the product and should be kept close to the device and accessible for the staff at any time. The illustrations in the manual are for better demonstration of the facts. They are not necessarily to scale and can slightly differ from the actual design.

2.2 Explanation of Symbols

Special notes in this manual are characterized by symbols. The notes are introduced by signal words which express the magnitude of danger. Please follow this advice and act carefully in order to avoid accidents, damage, and injuries.

Warning notes:

| | |
|---|--|
|  | DANGER! This symbol in connection with the signal word "Danger" indicates an immediate danger for the life and health of persons. Failure to heed these instructions can result in serious damage to health and even fatal injury. |
|  | WARNING! This symbol in connection with the word „Warning“ means a possibly impending danger for the life and health of persons. Failure to heed these instructions can result in serious damage to health and even fatal injury. |
|  | CAUTION! This symbol in connection with the signal word "Caution" indicates a possibly dangerous situation. Failure to heed these instructions can lead to minor injuries or damage of property. |



Special safety instructions:

| | |
|---|---|
|  | DANGER! This symbol in connection with the signal word "Danger" indicates an immediate danger for the life and health of persons due to voltage. Failure to heed these instructions can result in serious damage to health and even fatal injury. The operations may only be carried out by a professional electrician. |
|---|---|

Tips and recommendations:

| | |
|---|---|
|  | NOTE! ...points out useful tips and recommendations as well as information for an efficient and trouble-free operation. |
|---|---|

Reference marks:

-  Marks a reference to another chapter of this manual.
-  Marks a reference to another chapter of another document.

2.3 Statement of Warranties

The producer guarantees the functional capability of the process engineering and the selected parameters.

2.4 Demounting and Disposal

Unless acceptance and disposal of returned goods are agreed upon, demount the device considering the safety instructions of this manual and dispose it with respect to the environment.

Before demounting, disconnect the power supply and secure against re-start. Then disconnect the supply lines physically and discharge remaining energy. Remove operational supplies and other material.

Disposal:

Recycle the decomposed elements: Metal components in scrap metal, Electronic components in electronic scrap, Recycle plastic components, dispose the remaining components according to their material consistence.



CAUTION!

Wrong disposal causes environmental damages!
Electronic scrap, electronic components, lubricants and other auxiliary materials are subject to special refuse and can only be disposed by authorized specialists!

Local authorities and waste management facilities provide information about environmentally sound disposal.

Safety



CAUTION!

Please read the operating manual carefully, before using the device! Observe the installation instructions! Only start up the device if you have understood the operating manual. The operating company is obliged to take appropriate safety measure.
The initial operation may only be performed by qualified and trained staff.
Selection and installation of the devices as well as their embedding into the controlling system require qualified knowledge of the applicable laws and normative requirements on the part of the machine manufacturer.

2.5 General Causes of Risk

This chapter gives an overview of all important safety aspects to guarantee an optimal protection of employees and a safe and trouble-free operation. Non-observance of the instructions mentioned in this operating manual can result in hazardous situations.

2.6 Personal Protective Equipment

Employees have to wear protective clothing during the installation of the device to minimize danger of health.

Therefore:

Change into protective clothing before performing the works and wear them throughout the process.
Additionally observe the labels regarding protective clothing in the operating area.

Protective clothing:

| | |
|--|---|
| | <p>PROTECTIVE CLOTHING ... is close-fitting working clothing with light tear strength, tight sleeves and without distant parts. It serves preliminarily for protection against being gripped by flexible machine parts. Do not wear rings, necklaces or other jewellery.</p> |
| | <p>PROTECTIVE GLOVES ...for protecting the hands against abrasion, wear and other injury of the skin.</p> |
| | <p>PROTECTIVE HELMET ...for protection against injuries of the head.</p> |

2.7 Conventional Use

The ELGO-device is only conceived for the conventional use described in this manual.
The EMIX2 - ELGO- length measuring system only serves to measure lengths and distances.



CAUTION!

Danger through non-conventional use!

Non-intended use and non-observance of this operating manual can lead to dangerous situations.

Therefore:

- Only use the device as described
- Strictly follow the instructions of this manual

Avoid in particular:

- Remodelling, refitting or changing of the construction or single components with the intention to alter the functionality or scope of the device.

Claims resulting from damages due to non-conventional use are not possible.
Only the operator is liable for damages caused by non-conventional use.

2.8 Safety Instructions for Transport, Unpacking and Loading



CAUTION!

Transport the package (box, palette etc.) professionally. Do not throw, hit or fold it.

2.9 Handling of Packaging Material

Notes for proper disposal: ↗2.4

2.10 Inspection of Transport

Check the delivery immediately after the receipt for completeness and transport damage.
In case of externally recognizable transport damages:

- Do not accept the delivery or only accept under reserve.
- Note the extent of damages on the transportation documents or delivery note.
- File complaint immediately.



NOTE!

Claim any damage immediately after recognizing it. The claims for damage must be filed in the lawful reclaim periods.

2.11 Storage

Store the device only under the following conditions:

- Do not store outside
- Keep dry and dust-free
- Do not expose to aggressive media
- Protect from direct sun light
- Avoid mechanical shocks
- Storage temperature (↗4) needs to be observed
- Relative humidity (↗4) must not be exceeded
- Inspect packages regularly if stored for an extensive period of time (>3 months)

3 Product Features

The EMIX2 is an incremental magnetic length measuring system. The sensor technology and translator circuit are placed in the same small housing. The magnetic tape can also be fixed into a guiding rail by using the provided adhesive tape. The EMIX2 can be installed up to a maximum distance of 0.8 mm to the magnetic tape.

Overview of features:

- Direct contactless measurement
- The distance between sensor and measuring tape can vary between 0.1 and 0.8 mm
- Measuring length theoretical unlimited
- High resolution of 0.01 mm
- Repeating accuracy +/- 0.01 mm
- Very robust against pollution

3.1 Functional Principle

The basis of the magnetic incremental encoders consists of a scanning technology, which scans the north and south poles on the coded magnetic tape and produces a single Sine/Cosine wave for each pole.

The complete sine/cosine signal process is interpolated electronically. Depending on refinement of the interpolation, together with the pole distance of the magnetic tape, the resolution of the measuring system is determined. The magnetic tape (see 4.4) has a pole pitch of 2 mm. A special evaluation electronic (translator) processes the sine/cosine wave into square output signals from the signal information of the magnetic tape. These square signals are equivalent to conventional optical rotary- or linear encoder outputs.

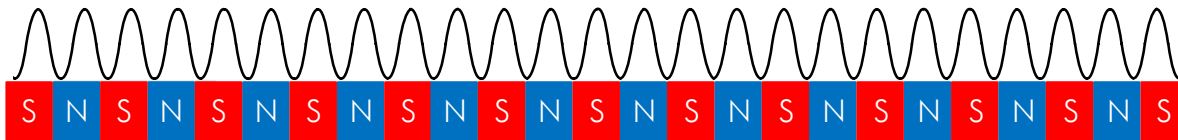

Figure 1: Magnetic tape

3.2 Pulse Diagram

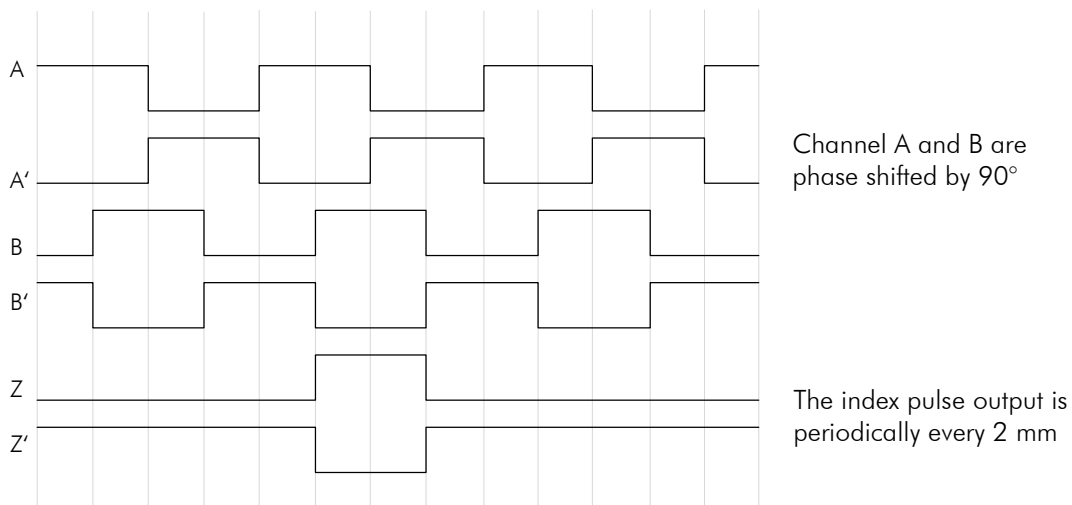

Figure 2: Pulse diagram

4 Technical Data

4.1 Identification

The type label serves for the identification of the unit. It is located on the housing of the sensor and gives the exact type designation (=order reference, \varnothing 8) with the corresponding part number. Furthermore, the type label contains a unique, traceable device number. When corresponding with ELGO please always indicate this data.

4.2 Dimensions Sensor

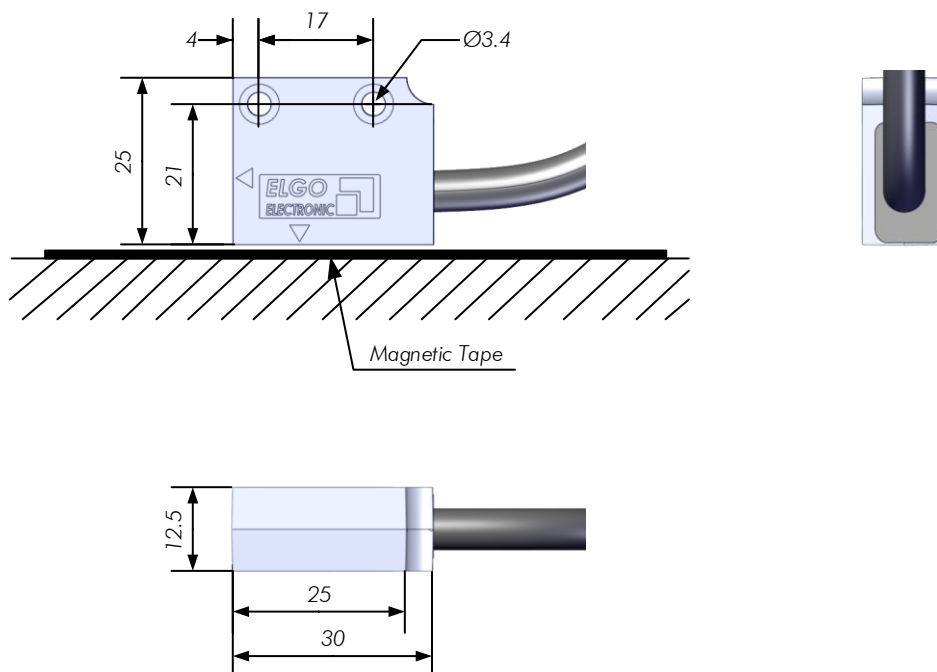

Figure 3: Dimensions Sensor

4.3 Technical Data Sensor

EMIX2 (Standard version)

Mechanical data

| | |
|--------------------------|--|
| Housing material | Zinc die cast |
| Housing dimensions | L x W x H = 30 x 12.5 x 25 mm (☞ 4.2) |
| Suitable magnetic tape | MB20-20-10-1-R |
| Maximum measuring length | unlimited |
| Connection type | open cable ends (plug connectors optionally ☞ 8) |
| Sensor cable | 1.5 m standard length (others on request) |
| Weight | approx. 35 g without cable; cable approx. 60 g/m |

Electrical data

| | |
|--|---|
| Power supply voltage | + 10 ... 30 VDC or 5 VDC (depends on order information) |
| Residual ripple | 10-30 V: <10 %; 5 V: +/-25 mV |
| Consumption | max. 150 mA at 10-30 V |
| Measurement principle | incremental |
| Output levels | 10-30 VDC or 5 V-TTL line driver (depends on order information) |
| Output signals | A/A', B/B', Z/Z', push-pull, durable short circuit proof |
| System resolution | 0.01 mm (at 4 edge triggering) |
| Repeat accuracy | +/- 0.01 mm |
| Output frequency | 100 kHz per channel |
| Output current | max. 20 mA per channel |
| Operational speed | max. 4 m / s |
| System accuracy in μm at 20°C | +/- (20 μm + 20 μm x L) L= measuring length in meters |
| Distance sensor / magnetic tape | max. 0.8 mm |
| Basic pole pitch | 2 mm |

Ambient conditions

| | |
|-----------------------|---|
| Storage temperature | -25 ... +85° C |
| Operation temperature | -10 ... +70° C (-25 ... +85° C on request) |
| Humidity | max. 80 %, not condensing |
| Protection class | IP67 |

4.4 Technical Data Magnetic Tape

The magnetic tape consists of two components:

- The actual magnetic tape which carries the position information
- A mechanical stainless steel back iron

Magnetic Tape MB20-20-10-1-R

| | |
|---------------------------------|--|
| Coding | incremental, single track system |
| Pole pitch | 2 mm |
| Operation temperature installed | -20 ... +65° C (-20 ... +80° C when using without adhesive tape, options „B“ or „D“) |
| Storage temperature uninstalled | Short-term: -10 ... +60° C Medium-term: 0 ... +40° C Long-term: +18° C (-20 ... +80° C when using without adhesive tape, options „B“ or „D“) |
| Gluing temperature: | +18 ... +30° C |
| Relative humidity | max. 95 %, not condensing |
| Accurateness 20°C in mm | +/- (20 μm +20 μm x L) L= measuring length in meters |
| Material carrier tape | Precision strip 1.4310 / X10CrNi 18-8 (EN 10088-3) |
| Double-faced adhesive tape | 3M-9088 (observe instructions), others on request |
| Dimensions | ➔ without adhesive tape: 10 mm (+/- 0,1) x 1,35 mm (+/- 0,11) ➔ with adhesive tape (excl. carrier): 10 mm (+/- 0,1) x 1,56 mm (+/- 0,13) ➔ with adhesive tape (incl. carrier): 10 mm (+/- 0,1) x 1,63 mm (+/- 0,14) |
| Length expansion coefficient | $\alpha \approx 16 \times 10^{-6} \text{ 1/K}$ |
| Thermal length expansion | $\Delta L[\text{m}] = L[\text{m}] \times \alpha[\text{1/K}] \times \Delta \vartheta[\text{K}]$ (L = tape length in meters, $\Delta \vartheta$ = relative temperature change) |
| Bending radius | min. 150 mm |
| Available lengths | 32 m (up to 70m on request) |
| Weight magnetic tape | ca. 62 g/m (incl. magnetic tape and cover tape) |
| Tape imprint | ELGO standard, printing colour black, digit height ≥ 5 mm |
| Influence of external magnets | External magnetic fields must not exceed 64 mT (640 Oe; 52 kA/m) on the surface of the magnetic tape, as this could damage or destroy the code on the tape. |
| Protection class | IP65 |

5 Installation and First Start-Up

**CAUTION**

Please read the operating manual carefully before using the device! Strictly observe the Installation instructions! In case of damage caused by failure to observe this operating manual, the warranty expires.

ELGO is not liable for any secondary damage and for damage to persons, property or assets.

The operator is obliged to take appropriate safety measures.

The first start-up may only be performed by qualified staff that has been trained and authorized by the operator.

5.1 Operating Area

**WARNING!**

Do not use the device in explosive or corrosive environments!
The device must not be installed close to sources of strong inductive or capacitive interference or strong electrostatic fields!

**CAUTION!**

The electrical connections must be made by suitably qualified personnel in accordance with local regulations.



The device may be designed for switchboard mounting. During work on the switchboard, all components must be de-energized if there is a danger of touching the energized parts! (protection against contacts)

Wiring works may only be performed in the de-energized state!



Thin cable strands have to be equipped with end sleeves!

Before switching on the device, connections and plug connectors have to be checked!



The device must be mounted in a way that it is protected against harmful environmental influences such as splashing water, solvents, vibration, shock and severe pollution and the operating temperature must not be exceeded.

5.2 Installation of the Magnetic Tape



NOTE External Magnetic Fields

The magnetic tape must not be influenced by external magnetic fields!
The magnetic tape must not come into direct contact with other magnetic fields (e.g. permanent magnets, magnetic clamps, electromagnets, magnetic stands)! This may cause irreparable damage, which will compromise the measuring accuracy or even the functioning.

5.2.1 The Magnetic Tape MB20-20-10-1-R

In the standard case, the magnetic tape is delivered as described
It is installed by gluing it to the respective mounting surface.

The magnetic tape consists of 2 pre-assembled components:

- A magnetized, flexible plastic tape (Pos. 3), which is connected with a magnetically conductive steel tape as inference band (Pos. 4) and is supplied with an adhesive tape (Pos. 5).
- A magnetized permeable cover tape (Pos. 1), which serves for the mechanical protection of the plastic tape (not required for the measurement) and is supplied with an adhesive tape (Pos. 2).

Therefore a divergent tape structure and scope of delivery is also possible.
The cover tape is also available separately

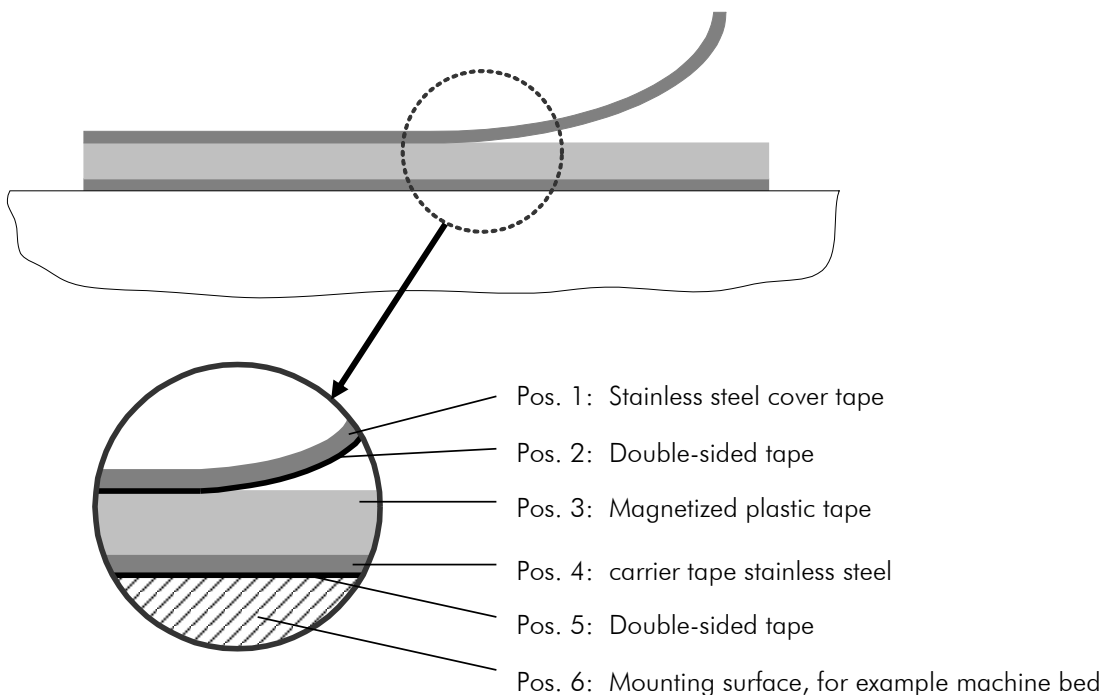

Figure 4: Components of the magnetic tape

5.2.2 Handling

In order to avoid tension in the tape, it must not be stretched, compressed or twisted. It should be stored with the magnetized plastic tape to the outside (see Figure5), the minimum bending radius must be noted here

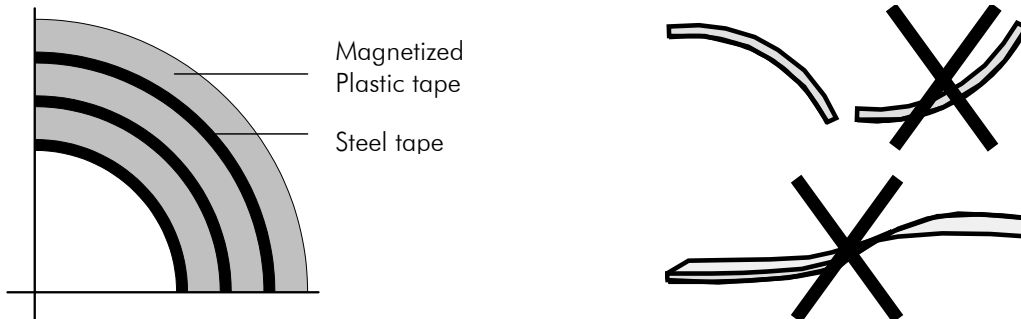

Figure5: Handling

5.2.3 Processing hint for the gluing of magnetic tapes

Surface-Preparation: In order to guarantee optimal adhesion, all anti-adhesive contamination (e.g. oil, grease, dust, separating agents) has to be removed using solvents with residue-free evaporation. Suitable agents are ketones or alcohols. Typical solvents for cleaning the surface are a 50/50 isopropyl alcohol/water mixture or heptane. Those agents are offered by Loctite and 3M among others as surface cleaners. When using solvents, always observe the manufacturer instructions! If the surface is copper, brass etc., it should be sealed to avoid oxidation.

Contact-Pressure: The strength of the adhesion is directly dependent on the contact the adhesive can form with the surface. Therefore it is important to use as much pressure as possible when gluing the tape, possibly by using aids such as draw rolls. The optimum contact pressure is 4...5 kg/cm².

Gluing temperature: The optimal gluing temperature is between + 18° C and 30° C. Avoid colder sticking surfaces than + 10°C, because in this case the adhesive becomes too hard and perhaps a sufficient immediate adhesion is hardly to achieve. After proper sticking, the stability of the connection is ensured also when the temperature is below zero. The final tackiness of a sticking is from experience reached after approximately 72 hours (at + 21° C). For gluing use only the supplied adhesive tape.

5.2.4 Cutting and Gluing

Before starting the gluing process, both the magnetic and the cover tape have to be cut to the required length

Length cover tape = measuring length + sensor length + 50mm (end caps)



NOTE!

When sticking the magnetic tape pay attention to the markings on the tape and the Sensor. Improper installation does not provide the correct values. A already glued magnetic tape is destroyed after the removal, and cannot be used again. Note also the direction of counting of the measuring system

Preferably the magnetic tape should be glued close to an edge or into a groove, which should be deep enough to embed the magnetic tape and the cover tape.

When unprotected, the cover tape may peel off!

Therefore:

Use tape end caps (☞ 8.1) or let the cover tape overlap the end of the magnetic tape and fix it with a screw.

The tape must be glued smoothly on the surface. The measuring accuracy decreases if the tape is not even!

Before gluing the magnetic tape and the cover tape onto the surface, they should be left lying on the mounting surface for ca. 30 minutes so that the temperature matches. This prevents strain in the tape due to thermal expansion.

Mounting steps:

1. Thoroughly clean surface (☞ 5.2.3)
2. Acclimatization: let magnetic tape and cover tape adjust their temperature
3. Remove the protection foil from the magnetic tape
4. Glue magnetic tape under great pressure
5. Thoroughly clean surface of magnetic tape
6. Remove the protection foil from the cover tape
7. Glue the cover tape under great pressure
8. Safeguard the ends of the cover tape against peeling off, e.g. by using end caps (☞ 8.1)

5.2.1 Resistance against Chemical Influence

Table 1: Resistance against chemical influence

Show no or little effect in constant contact after 2-5 years:

| | | | |
|------------------|---------------|-------------|---------------|
| formic acid | glycerol 93°C | linseed oil | soy beans oil |
| cotton seed oil | N-hexane | lactic acid | |
| formaldehyde 40% | Iso octane | petroleum | |

Show weak to moderate effects in constant contact after approximately 1 year:

| | | | |
|-----------|-----------------|-------------------------------|------------------------------|
| acetone | gasoline | acetic acid 30% | oleic acid |
| acetylene | steam | acetic acid, pure acetic acid | sea water |
| ammonia | acetic acid 20% | isopropyl ether | stearic acid 70°C, anhydrous |
| kerosene | | | |

Have strong effects when contacting permanently after 1-5 months:

| | | | |
|-------------------|-----------------------------|-----------------------------|-----------------|
| benzene | nitric acid 70% | turpentine | toluene |
| lacquer solvent | nitric acid, red, vitriolic | carbon tetrachloride | tetrahydrofuran |
| trichloroethylene | nitrobenzene | hydrochloric acid 37%, 93°C | xylene |

5.3 Installation of the Sensor

For mounting the sensor two M3 screws are required. Observe the tolerances stated below.

5.3.1 Mechanical Tolerances

| Tolerances | |
|--------------------|---|
| Magnetic tape type | MB20-20-10-1-R |
| Ride height | 0.1 mm...max. 0.8 mm |
| Pitch | The maximum distance of 0.8 mm must not be exceeded at any position |
| Yaw angle | +/- 5 ° |
| Roll | The maximum distance of 0.8 mm must not be exceeded at any position |
| Lateral offset | +/- 2.5 mm |

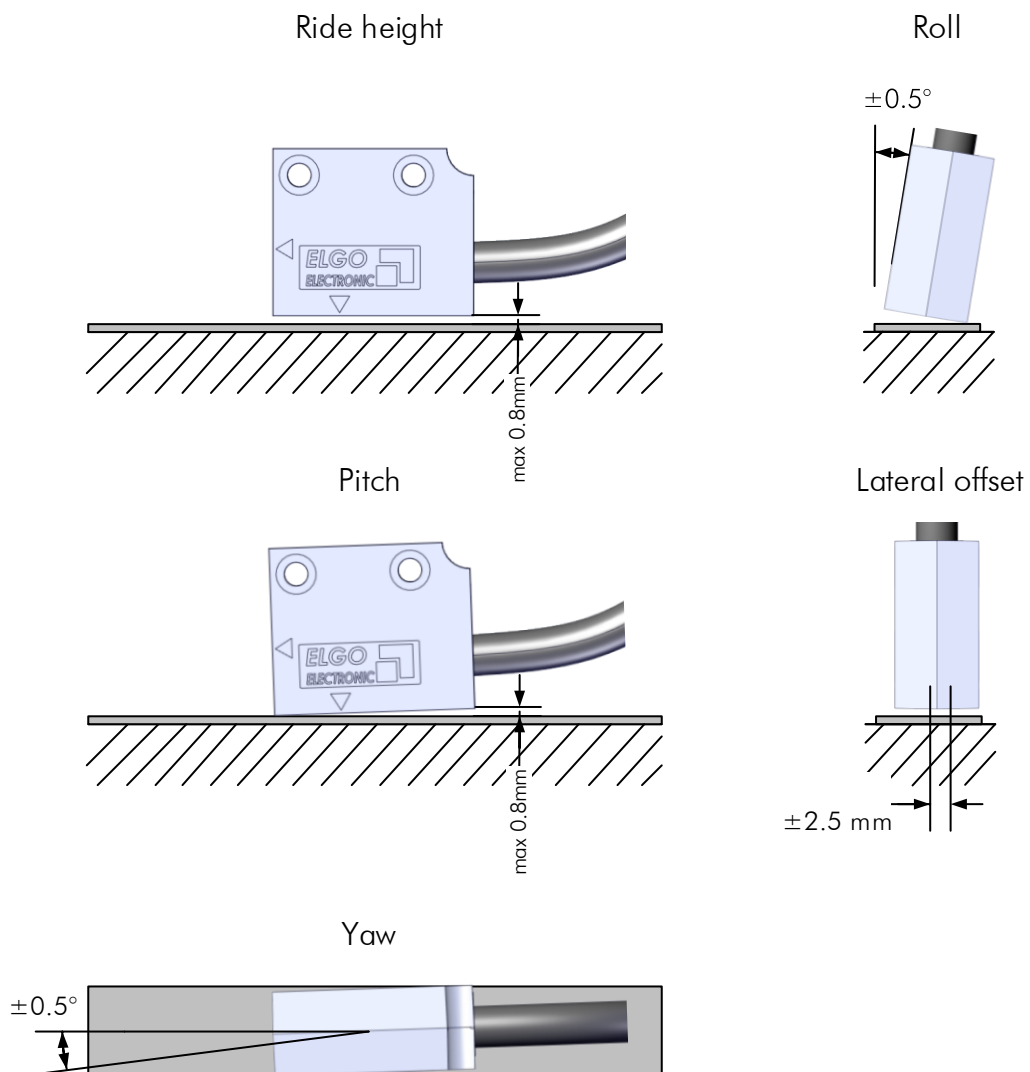

Figure 6: Tolerances

5.3.2 Alignment of Sensor / Magnetic Tape

Since the active sensor surface is not in the center of the sensor housing, it should be ensured that the sensor head is aligned and mounted such that the active sensor surface is in the middle of the magnetic tape. This is achieved in a simple manner and without additional equipment. Just use the correct side of the sensor (see figure below) and install it flush with the magnetic tape.

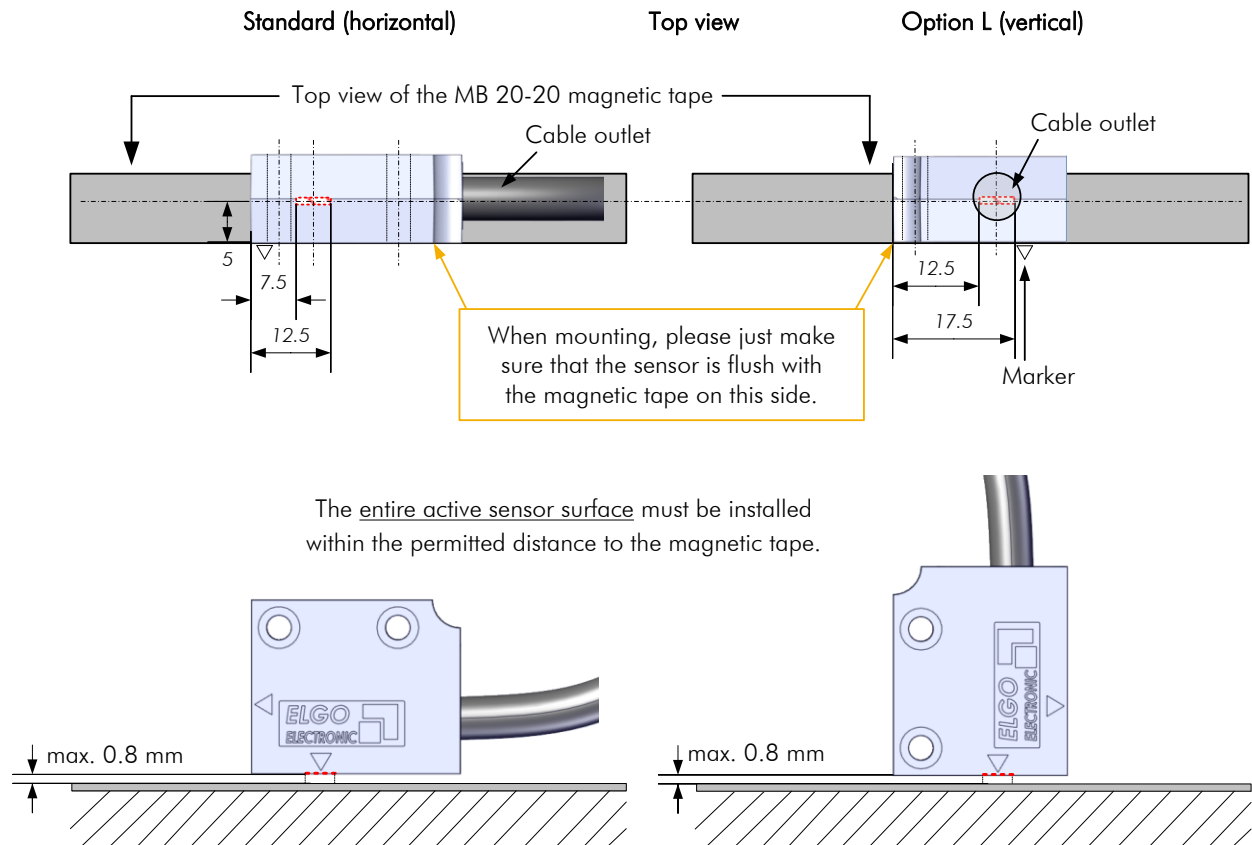

Figure 7: Alignment of the Sensor

6 Connections

6.1 Pin Assignment

Table 2: Pin Assignment open cable ends

| Color | Function | Description |
|--------|----------|--------------------|
| White | GND | 0V |
| Brown | VCC | 10-30 V / 5 VDC |
| Green | A | Channel A |
| Yellow | B | Channel B |
| Black | Z | Channel Z |
| Violet | A' | Channel A inverted |
| Orange | B' | Channel B inverted |
| Grey | Z' | Channel Z inverted |
| Shield | PE | PE |

Table 3: Pin assignment Option D1, 9-pin D-SUB plug (ELGO standard)

| Drawing | Pin | Function | Description |
|----------------------|-----|----------|--------------------|
| <p>(solder side)</p> | 1 | GND | 0V |
| | 2 | VCC | 10-30 V / 5 VDC |
| | 3 | A | Channel A |
| | 4 | B | Channel B |
| | 5 | N.C. | Not connected |
| | 6 | A' | Channel A inverted |
| | 7 | B' | Channel B inverted |
| | 8 | Z | Channel Z |
| | 9 | Z' | Channel Z inverted |

Table 4: Pin Assignment Option D3, 8-pin circular plug (for SKA-1)

| Drawing | Pin | Function | Description |
|----------------------|-----|----------|--------------------|
| <p>(solder side)</p> | 1 | GND | 0V |
| | 2 | VCC | 10-30 V / 5 VDC |
| | 3 | A | Channel A |
| | 4 | B | Channel B |
| | 5 | Z | Channel Z |
| | 6 | A' | Channel A inverted |
| | 7 | B' | Channel B inverted |
| | 8 | Z' | Channel Z inverted |

7 Disturbances, Maintenance, Cleaning

This chapter describes possible causes for disturbances and measures for their removal. In case of increased disturbances, please follow the measures for fault clearance in chapter 7.1.

In case of disturbances that cannot be eliminated by following the advice and the fault clearance measures given here, please contact the manufacturer (see second page).

7.1 Fault Clearance



CAUTION!

The device, the connection line and the signal cable must not be installed next to sources of interference that emit strong inductive or capacitive interference or strong electrostatic fields.

External perturbations can be avoided through suitable cable routing.



The screen of the signal output cable should only be connected to the following circuit on one side. The screens should not be grounded on both sides. Signal cables always have to be routed separately from the load power line. A safety distance of at least 0,5 m has to be kept from inductive and capacitive sources of interference such as contactors, relays, motors, switching power supplies, clocked controllers etc.!

If interferences occur in spite of all the items stated above being observed, please proceed as follows:

1. Installation of RC-circuits via contactor coils of AC-contactors (e.g. 0,1 μ F / 100 Ω)
2. Installation of recovery diodes via DC-inductors
3. Installation of RC-circuits via the different motor phases (in the terminal box of the motor)
4. Do not connect protective earth and ground
5. Connect a mains filter ahead of the external power pack

7.2 Re-start after Fault Clearance

After the fault clearance:

1. Reset the emergency stop mechanism if necessary
2. Reset the error report at the super-ordinate system if necessary.
3. Ensure that there are no persons in the danger area.
4. Follow the instructions from chapter 5.



WARNING!

Danger of injury through non-conventional fault clearance!

Non-conventional fault clearance can lead to severe injuries and damage of property.

Therefore:

- Any work to clear the faults may only be performed by sufficiently qualified staff
- Arrange enough space before starting the works
- Make sure that the mounting area is clean and tidy. Loose components and tools are sources of accidents.

If components need to be replaced:

- Pay attention to a correct installation of the spare parts.
- Reinstall all the fixing elements properly
- Before turning on the device, ensure that all covers and safety equipment is installed correctly and functions properly

7.3 Maintenance

The device is maintenance-free.

7.4 Cleaning



WARNING!

The device can only be cleaned with a damp cloth, do not use aggressive cleanser!

8 Type Designation

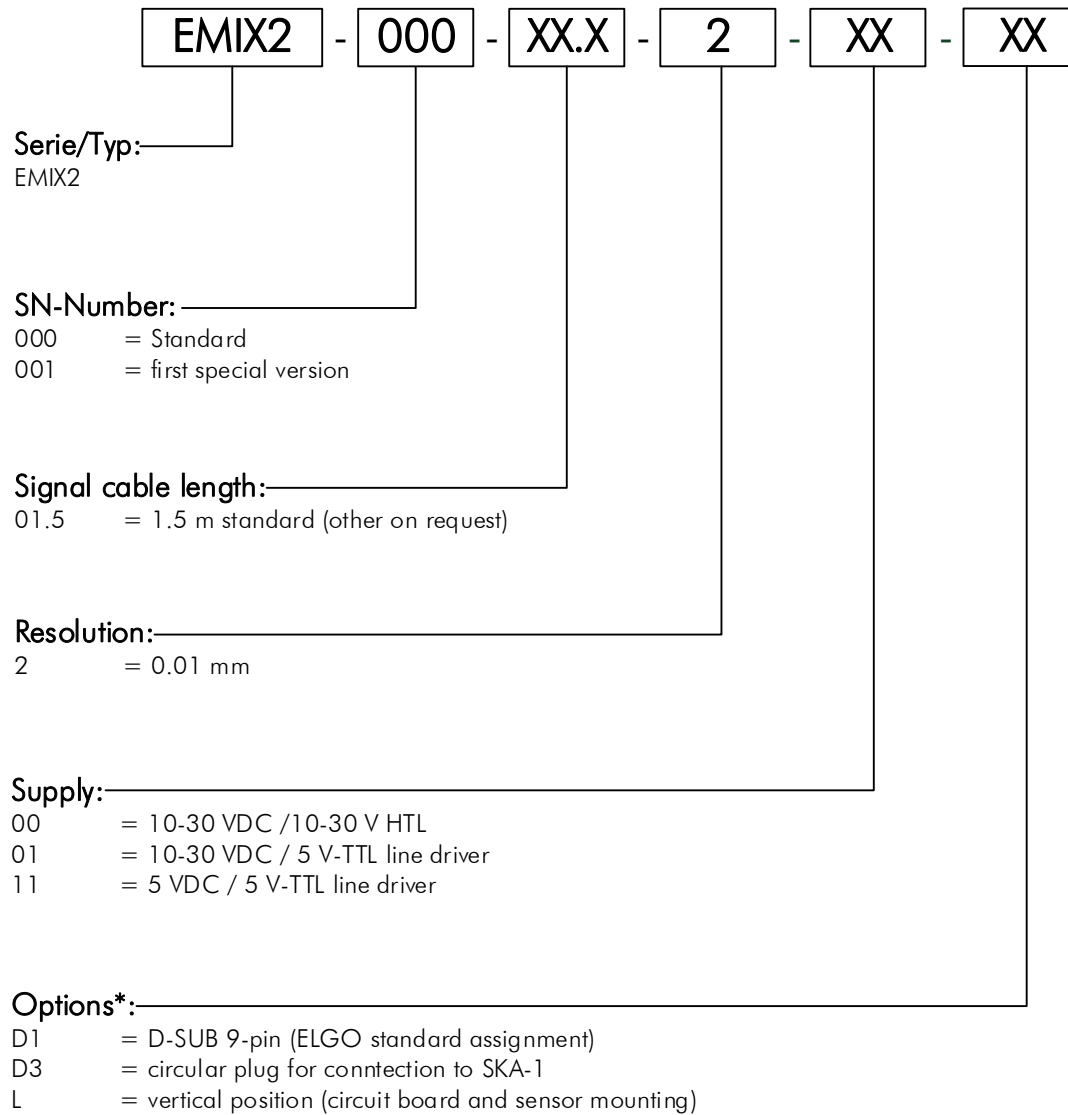

*multiple selection possible



NOTE

When ordering, please use the here described ordering code (Type Designation). Options that are not required are filled in with „-“.

8.1 Accessories

Table 1 Accessories

| Order designation | Description | Part No. |
|-------------------|--|----------|
| MB20-20-10-1-R | Magnetic tape for EMIX2 | |
| End cap set 10mm | End cap set for fix the magnetic tape | |
| FS-1000 | Guide rail for magnetic tape, length 1.0 m Available up to 2.0 m length For larger measuring distances the guide rails can be mounted end-to-end | |
| FW2070 | Guide carriage EMIX2 | |

Notices:

Notes:

9 Index

| | | | |
|---|--------|---|--------|
| Accessories | 20 | Maintenance..... | 18, 19 |
| Accident prevention regulations..... | 4 | Mechanical Tolerances | 15 |
| Alignment of Sensor / Magnetic Tape | 16 | Operating area | 11 |
| Causes of risk..... | 5 | Operational safety..... | 4 |
| Cleaning..... | 18, 19 | Order reference | 8 |
| Connections | 17 | Packaging material..... | 6 |
| Conventional use..... | 6 | Product features | 7 |
| Demounting | 5 | Protection against contact | 11 |
| Device number | 8 | Protective equipment | 5 |
| Dimensions Sensor..... | 8 | Pulse diagram | 7 |
| Disposal..... | 5 | Resistance against chemical influence | 14 |
| Disturbances | 18 | Safety | 4, 5 |
| Explanation of symbols..... | 4 | Safety instructions | 4 |
| Fault clearance..... | 18 | Safety rules | 4 |
| First start-up | 11 | Start-up | 11 |
| Functional principle | 7 | Storage | 6 |
| Identification | 8 | Technical Data Magnetic Tape | 10 |
| Installation | 11 | Technical Data Sensor | 9 |
| Installation of the Magnetic Tape | 12 | Transport..... | 6 |
| Installation of the Sensor | 15 | Transport damage | 6 |
| Magnetic tape | | Type designation | 8, 20 |
| Structure | 10 | | |

Document- No.: 799000076 / Rev. 4
Document- Name: EMIX2-000-MA-E_19-17
Subject to change - © 2017
ELGO Electronic GmbH & Co. KG

ELGO Electronic GmbH & Co. KG
Measuring | Positioning | Control
Carl - Benz - Str. 1, D-78239 Rielasingen
Fon: +49 (0) 7731 9339-0, Fax: +49 (0) 7731 28803
Internet: www.elgo.de, Mail: info@elgo.de

