

Operating Manual

SERIES GMIX2

Magnetic Incremental Linear Encoder for large Measuring Distances



- Predestined for applications in storage and conveyor technology
- Mounting distance from sensor to magnetic tape up to 4 mm
- Compact sensor head with integrated evaluation electronics
- Magnetic measuring principle with contactless scanning
- Speed proportional square wave signal outputs
- Wear-free scanning of the magnetic tape
- Resolution 2.5 mm (at 4-edge triggering)
- Insensitive to dust, dirt and water
- High IP67 protection class
- Quick and easy to install

Publisher ELGO Electronic GmbH & Co. KG
Carl-Benz-Str. 1
D-78239 Rielasingen-Worblingen

Technical Support  +49 (0) 7731 9339 - 0
 +49 (0) 7731 2 88 03
 info@elgo.de

Document- No. 799000019

Document- Name GMIX2-000-MA-E_39-19

Document- Revision Rev. 0

Issue Date 2019-09-24

Copyright © 2019, ELGO Electronic GmbH & Co. KG

1 Contents

1	Contents	3
2	List of Figures.....	4
3	List of Tables	4
4	General, Safety, Transport and Storage.....	5
4.1	Information Operating Manual	5
4.2	Explanation of Symbols.....	5
4.3	Statement of Warranties.....	5
4.4	Demounting and Disposal.....	6
4.5	General Causes of Risk	6
4.6	Personal Protective Equipment	6
4.7	Conventional Use	7
4.8	Safety Instructions for Transport, Unpacking and Loading	7
4.9	Handling of Packaging Material.....	7
4.10	Inspection of Transport	7
4.11	Storage	7
5	Product Features	8
5.1	Functional Principle.....	8
5.2	Pulse Diagram.....	8
6	Technical Data	9
6.1	Identification	9
6.2	Sensor Dimensions.....	9
6.3	Technical Data Sensor.....	10
6.4	Technical Data Magnetic Tape	11
7	Installation and First Start-Up.....	12
7.1	Operating Area	12
7.2	Installation of the Magnetic Tape	13
7.3	Mounting the Sensor Head.....	16
7.4	Mounting Direction	17
7.5	Alignment of the Sensor to the Magnetic Tape	17
7.6	Alignment of the Sensor to the Magnetic Ring	18
7.7	Connections.....	18
8	Disturbances, Maintenance, Cleaning.....	19
8.1	Fault Clearance.....	19
8.2	Re-start after Fault Clearance	19
8.3	Maintenance	19
8.4	Cleaning	19
9	Type Designation	20
9.1	Accessories	20
10	Index	23

2 List of Figures

Figure 1: GMIX2	8
Figure 2: Magnetic Tape Encoding.....	8
Figure 3: Output Pulse Diagram	8
Figure 4: Sensor Dimensions	9
Figure 5: Components of the magnetic tape	13
Figure 6: Handling	14
Figure 7: Mounting tolerances	16
Figure 8: Alignment of the sensor to the magnetic tape	17
Figure 9: Alignment of the sensor to the magnetic ring	18

3 List of Tables

Table 1: Resistance against Chemical Influence.....	15
Table 2: Mounting tolerances	16
Table 3: Pin assignment of the open cable ends	18
Table 4: Accessories	20

4 General, Safety, Transport and Storage

4.1 Information Operating Manual



This manual contains important information regarding the handling of the device. For your own safety and operational safety, please observe all safety warnings and instructions. Precondition for safe operation is the compliance with the specified safety and handling instructions. Moreover, the existing local accident prevention regulations and the general safety rules at the site of operation have to be observed.

Please read the operating manual carefully before starting to work with the device! It is part of the product and should be kept close to the device and accessible for the staff at any time. The illustrations in the manual are for better demonstration of the facts. They are not necessarily to scale and can slightly differ from the actual design.

4.2 Explanation of Symbols

Special notes in this manual are characterized by symbols. The notes are introduced by signal words which express the magnitude of danger. Please follow this advice and act carefully in order to avoid accidents, damage, and injuries.

Warning notes:

	DANGER! This symbol in connection with the signal word "Danger" indicates an immediate danger for the life and health of persons. Failure to heed these instructions can result in serious damage to health and even fatal injury.
	WARNING! This symbol in connection with the word „Warning“ means a possibly impending danger for the life and health of persons. Failure to heed these instructions can result in serious damage to health and even fatal injury.
	CAUTION! This symbol in connection with the signal word "Caution" indicates a possibly dangerous situation. Failure to heed these instructions can lead to minor injuries or damage of property.



Special safety instructions:

	DANGER! This symbol in connection with the signal word "Danger" indicates an immediate danger for the life and health of persons due to voltage. Failure to heed these instructions can result in serious damage to health and even fatal injury. The operations may only be carried out by a professional electrician.
---	---

Tips and recommendations:

	NOTE! ...points out useful tips and recommendations as well as information for an efficient and trouble-free operation.
---	---

Reference marks:

-  Marks a reference to another chapter of this manual.
-  Marks a reference to another chapter of another document.

4.3 Statement of Warranties

The producer guarantees the functional capability of the process engineering and the selected parameters.

4.4 Demounting and Disposal

Unless acceptance and disposal of returned goods are agreed upon, demount the device considering the safety instructions of this manual and dispose it with respect to the environment.

Before demounting, disconnect the power supply and secure against re-start. Then disconnect the supply lines physically and discharge remaining energy. Remove operational supplies and other material.

Disposal: Recycle the decomposed elements: Metal components in scrap metal, Electronic components in electronic scrap, Recycle plastic components, dispose the remaining components according to their material consistence.



CAUTION!

Wrong disposal causes environmental damages! Electronic scrap, electronic components, lubricants and other auxiliary materials are subject to special refuse and can only be disposed by authorized specialists!

Local authorities and waste management facilities provide information about environmentally sound disposal.

Safety



CAUTION!

Please read the operating manual carefully, before using the device! Observe the installation instructions! Only start up the device if you have understood the operating manual. The operating company is obliged to take appropriate safety measure. The initial operation may only be performed by qualified and trained staff. Selection and installation of the devices as well as their embedding into the controlling system require qualified knowledge of the applicable laws and normative requirements on the part of the machine manufacturer.

4.5 General Causes of Risk

This chapter gives an overview of all important safety aspects to guarantee an optimal protection of employees and a safe and trouble-free operation. Non-observance of the instructions mentioned in this operating manual can result in hazardous situations.

4.6 Personal Protective Equipment

Employees have to wear protective clothing during the installation of the device to minimize danger of health.

Therefore:

Change into protective clothing before performing the works and wear them throughout the process. Additionally observe the labels regarding protective clothing in the operating area.

Protective clothing:

	<p>PROTECTIVE CLOTHING</p> <p>... is close-fitting working clothing with light tear strength, tight sleeves and without distant parts. It serves preliminarily for protection against being gripped by flexible machine parts. Do not wear rings, necklaces or other jewelry.</p>
	<p>PROTECTIVE GLOVES</p> <p>...for protecting the hands against abrasion, wear and other injury of the skin.</p>
	<p>PROTECTIVE HELMET</p> <p>...for protection against injuries of the head.</p>

4.7 Conventional Use

The ELGO-device is only conceived for the conventional use described in this manual.
The magnetic linear encoder GMIX2 only serves to measure lengths, positions, angle and speeds.



CAUTION! Danger through non-conventional use!

Non-intended use and non-observance of this operating manual can lead to dangerous situations.
Therefore:

- Only use the device as described
- Strictly follow the instructions of this manual

Avoid in particular:

- Remodeling, refitting or changing of the construction or single components with the intention to alter the functionality or scope of the device.

Claims resulting from damages due to non-conventional use are not possible.
Only the operator is liable for damages caused by non-conventional use.

4.8 Safety Instructions for Transport, Unpacking and Loading



CAUTION!

Transport the package (box, palette etc.) professionally.
Do not throw, hit or fold it.

4.9 Handling of Packaging Material

Notes for proper disposal: ☞ 4.4

4.10 Inspection of Transport

Check the delivery immediately after the receipt for completeness and transport damage.
In case of externally recognizable transport damages:

- Do not accept the delivery or only accept under reserve.
- Note the extent of damages on the transportation documents or delivery note.
- File complaint immediately.



NOTE!

Claim any damage immediately after recognizing it.
The claims for damage must be filed in the lawful reclaim periods.

4.11 Storage

Store the device only under the following conditions:

- Do not store outside
- Keep dry and dust-free
- Do not expose to aggressive media
- Protect from direct sun light
- Avoid mechanical shocks
- Storage temperature (☞ 6.3) needs to be observed
- Relative humidity (☞ 6.3) must not be exceeded
- Inspect packages regularly if stored for an extensive period of time (>3 months)

5 Product Features

GMIX2 is an incremental sensor that can be mounted at a distance of up to 4 mm to the magnetic tape (☞ 7.5). For rotative resp. radial applications a magnet ring (☞ 7.6) can be used alternatively. The evaluation electronics, which converts the measured signals into 90° phase-shifted square-wave signals A and B, is already integrated in the sensor head.



Figure 1: GMIX2

Thus GMIX2 is ready-to-connect for subsequent electronics. The system is supplied with 10 ... 30 VDC and generates HTL output signal levels according to the supply voltage.

Essential features:

- Predestined for applications in storage and conveyor technology
- Compact sensor head with integrated evaluation electronics
- High mounting distance to magnetic tape (max. 4 mm)
- Speed proportional square wave signal outputs
- 2.5 mm resolution (at 4-edge triggering)
- Repeat accuracy ± 1 increment
- High protection class IP67

Applications:

With its resolution of 2.5 mm and a maximum operating speed of 10 m/s, the GMIX2 measuring system is ideally suited for applications in storage or conveyor technology or for longer measuring distances. Thanks to the wear-free magnetic measuring principle and the high IP67 protection class, the sensor always works unaffected and reliably even in harsh environments.

5.1 Functional Principle

The basis of the magnetic incremental encoder consists of a scanning technology, which scans the north and south poles on the coded magnetic tape and produces a single Sine/Cosine wave for each pole. The complete sine/cosine signal process is interpolated electronically. Depending on refinement of the interpolation, together with the pole distance of the magnetic tape, the resolution of the measuring system is determined.

The magnetic tape **MB20-50-10-1-R** has a pole pitch of 5 mm.

A special evaluation electronic (translator) processes the sine/cosine wave into HTL square output signals from the signal information of the magnetic tape. These square signals are equivalent to conventional optical rotary- or linear encoder outputs.

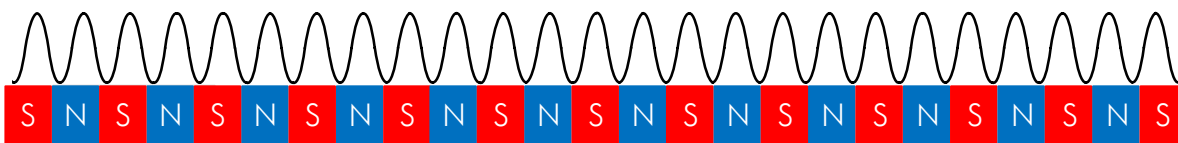

Figure 2: Magnetic Tape Encoding

5.2 Pulse Diagram

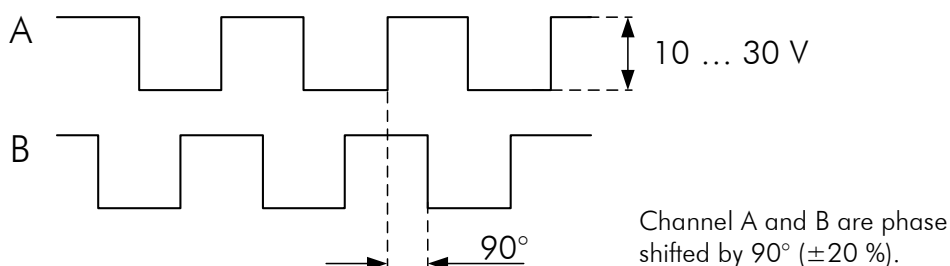

Figure 3: Output Pulse Diagram

6 Technical Data

6.1 Identification

The type label serves for the identification of the unit. It is located on the housing of the device and indicates the exact type designation (=order reference 9) with the corresponding part number. Furthermore, the type label contains a unique, traceable device number. When corresponding with ELGO please always indicate this data.

6.2 Sensor Dimensions

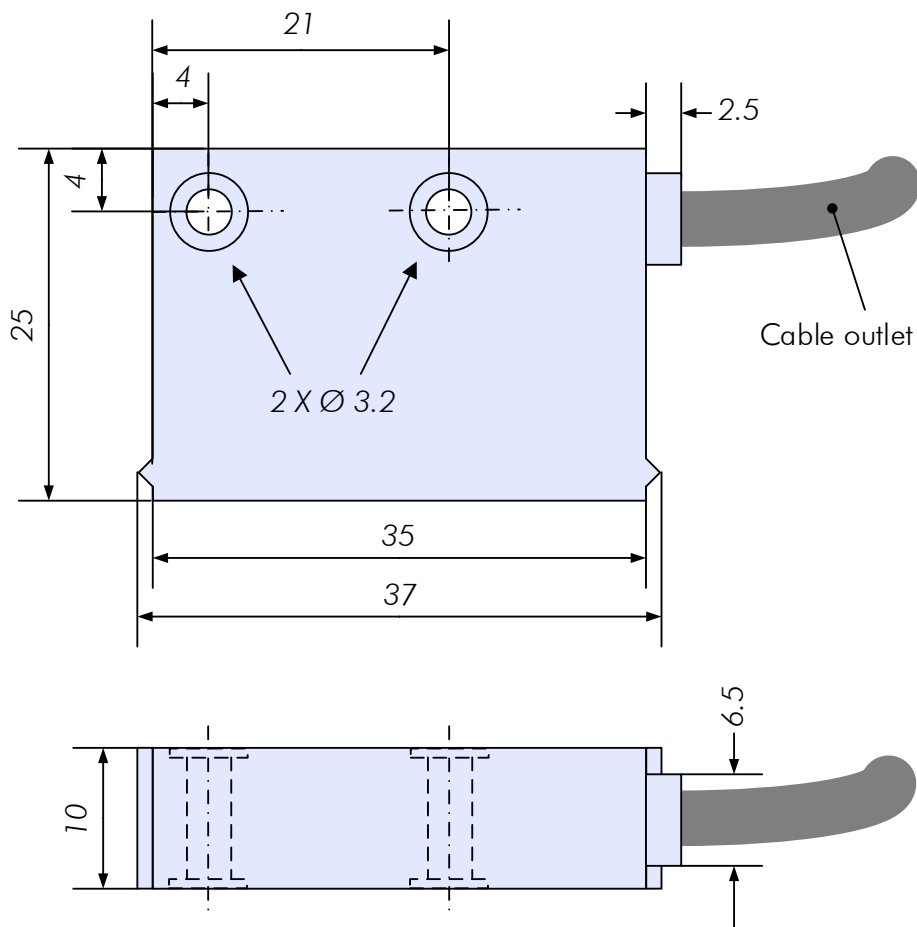

Figure 4: Sensor Dimensions

6.3 Technical Data Sensor

GMIX2 (standard version)

Mechanical Data

Measuring principle	incremental
Repeat accuracy	± 1 Increment
System accuracy at 20°C	±(25 + 20 x L), L = measuring length in meters
Distance sensor - magnetic tape	max. 4.0 mm
Housing material	HM-PA (polyamide), black
Housing dimensions (L x W x H)	38.5 x 25 x 10 mm
Required magnetic tape	MB20-50-10-1-R
Magnetic tape pole pitch	5 mm
Maximum measuring length	theoretically unlimited
Connections	open cable ends
Sensor cable	1.5 m standard cable length (others on request), drag-chain suitable
Sensor cable bending radius	min. 60 mm
Weight	sensor head: approx. 25 g (without cable); cable: approx. 45 g/m

Electrical Data

Power supply voltage	10 ... 30 VDC
Residual ripple	< 10 %
Current consumption	max. 30 mA
Output signals	A, B
Output levels	HTL
Resolution (at 4-edge triggering)	2.5 mm
Max. output frequency per channel	4 kHz
Max. operating speed	10.0 m/s

Environmental Conditions

Storage temperature	-20 ... +85° C
Operation temperature	-10 ... +70 °C (-25 ... +85 °C on request)
Humidity	max. 95 %, non-condensing
Protection class	IP67

6.4 Technical Data Magnetic Tape

The magnetic tape consists of two components:

- The actual magnetic tape which carries the position information
- A mechanical stainless steel back iron

Magnetic Tape MB20-50-10-1-R







Coding	incremental, single track system
Pole pitch	5 mm
Operation temperature installed	-20 ... +65° C
Storage temperature uninstalled	Short-term: -10 ... +60° C Medium-term: 0 ... +40° C Long-term: +18° C
Gluing temperature:	+18 ... +30° C
Relative humidity	max. 95 %, non-condensing
Accurateness 20°C in mm	±(25 + 20 x L), L = measuring length in meters
Material carrier tape	Precision strip 1.4310 / X10CrNi 18-8 (EN 10088-3)
Double-faced adhesive tape	3M-9088 (observe instructions), others on request
Width	10 mm
Height	magnetic tape without back iron stripe: 1.05 mm (± 0.10) with back iron, without adhesive tape: 1.35 mm (± 0.11) with back iron + adhesive tape, without protective foil: 1.55 mm (± 0.13) with back iron + adhesive tape + protective foil: 1.63 mm (± 0.14)
Length expansion coefficient	$\alpha \approx 16 \times 10^{-6} \text{ 1/K}$
Thermal length expansion	$\Delta L[\text{m}] = L[\text{m}] \times \alpha[\text{1/K}] \times \Delta \vartheta[\text{K}]$ (L = tape length in meters, $\Delta \vartheta$ = relative temperature change)
Bending radius	min. 150 mm
Available lengths	32 m (up to 70m on request)
Weight magnetic tape	ca. 62 g/m (incl. magnetic tape and cover tape)
Tape imprint	ELGO standard, printing color black, digit height ≥ 5 mm
Protection class	IP65
Influence of external magnets	External magnetic fields must not exceed 64 mT (640 Oe; 52 kA/m) on the surface of the magnetic tape because this could damage or destroy the code on the tape.

7 Installation and First Start-Up

	<p>CAUTION</p> <p>Please read the operating manual carefully before using the device! Strictly observe the Installation instructions! In case of damage caused by failure to observe this operating manual, the warranty expires.</p> <p>ELGO is not liable for any secondary damage and for damage to persons, property or assets.</p> <p>The operator is obliged to take appropriate safety measures.</p> <p>The first start-up may only be performed by qualified staff that has been trained and authorized by the operator.</p>
---	---

7.1 Operating Area

	<p>WARNING!</p> <p>Do not use the device in explosive or corrosive environments! The device must not be installed close to sources of strong inductive or capacitive interference or strong electrostatic fields!</p>
---	--

	<p>CAUTION!</p> <p>The electrical connections must be made by suitably qualified personnel in accordance with local regulations.</p>
	<p>The device may be designed for switchboard mounting. During work on the switchboard, all components must be de-energized if there is a danger of touching the energized parts! (protection against contacts)</p>
	<p>Wiring works may only be performed in the de-energized state!</p>
	<p>Thin cable strands have to be equipped with end sleeves!</p>
	<p>Before switching on the device, connections and plug connectors have to be checked!</p>
	<p>The device must be mounted in a way that it is protected against harmful environmental influences such as splashing water, solvents, vibration, shock and severe pollution and the operating temperature must not be exceeded.</p>

7.2 Installation of the Magnetic Tape



NOTE: External Magnetic Fields

The magnetic tape must not be influenced by external magnetic fields! The magnetic tape must not come into direct contact with other magnetic fields (e.g. permanent magnets, magnetic clamps, electromagnets, magnetic stands)! This may cause irreparable damage, which will compromise the measuring accuracy or even the functioning.

7.2.1 The Magnetic Tape MB20-50-10-1-R

In the standard case, the magnetic tape is delivered as described
It is installed by gluing it to the respective mounting surface.

The magnetic tape consists of 2 pre-assembled components (see Figure 7: Components of the magnetic tape below):

- A magnetized, flexible plastic tape (Pos. 3), which is connected with a magnetically conductive steel tape as inference band (Pos. 4) and is supplied with an adhesive tape (Pos. 5).
- A magnetized permeable cover tape (Pos. 1), which serves for the mechanical protection of the plastic tape (not required for the measurement) and is supplied with an adhesive tape (Pos. 2).

Therefore a divergent tape structure and scope of delivery is also possible.
The cover tape is also available separately

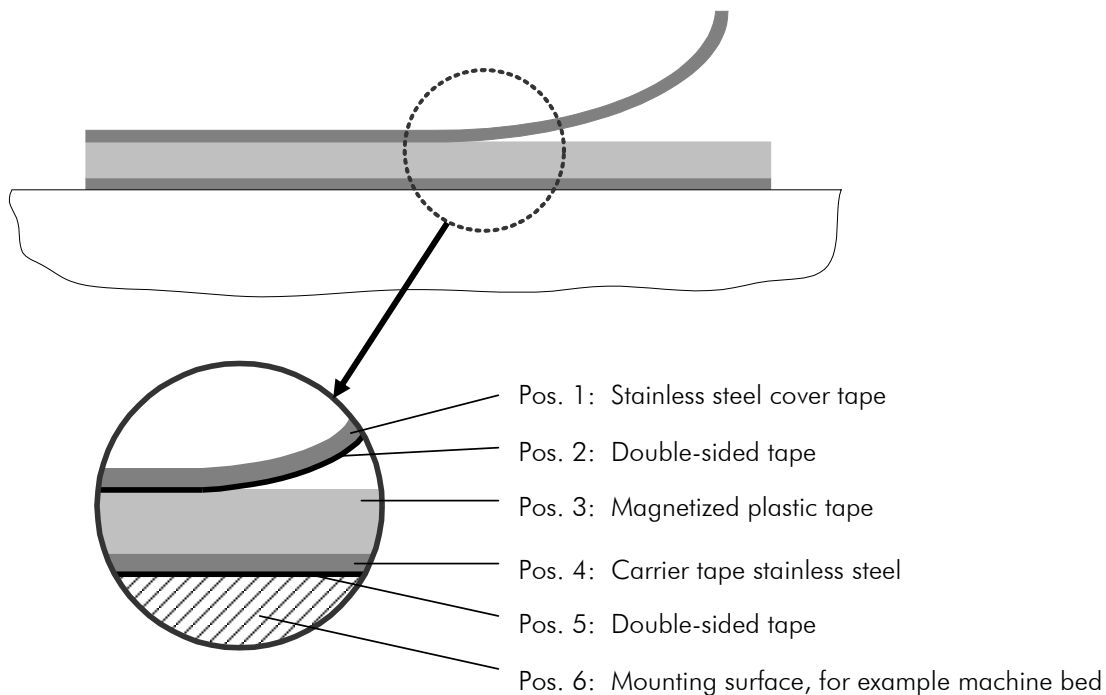

Figure 5: Components of the magnetic tape

7.2.2 Handling

In order to avoid tension in the tape, it must not be stretched, compressed or twisted. It should be stored with the magnetized plastic tape to the outside. The minimum bending radius is 150 mm.

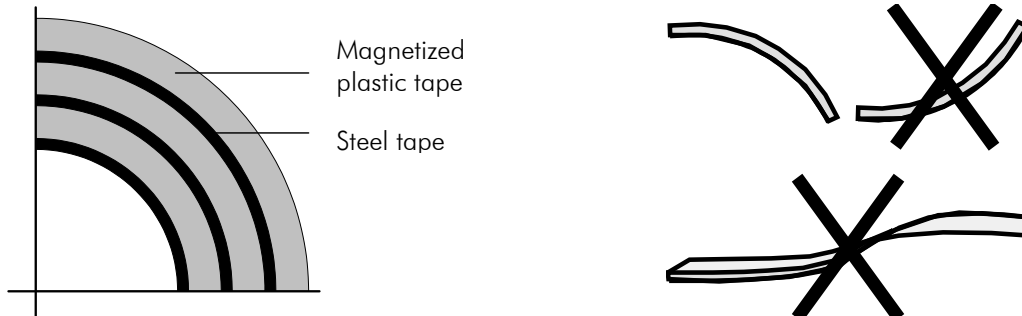

Figure 6: Handling

7.2.3 Processing hint for the gluing of magnetic tapes

Surface-Preparation: In order to guarantee optimal adhesion, all anti-adhesive contamination (e.g. oil, grease, dust, separating agents) has to be removed using solvents with residue-free evaporation. Suitable agents are ketones or alcohols. Typical solvents for cleaning the surface are a 50/50 isopropyl alcohol/water mixture or heptane. Those agents are offered by Loctite and 3M among others as surface cleaners. When using solvents, always observe the manufacturer instructions! If the surface is copper, brass etc., it should be sealed to avoid oxidation.

Contact-Pressure: The strength of the adhesion is directly dependent on the contact the adhesive can form with the surface. Therefore it is important to use as much pressure as possible when gluing the tape, possibly by using aids such as draw rolls. The optimum contact pressure is 4...5 kg/cm².

Gluing temperature: The optimal gluing temperature is between + 18° C and 30° C. Avoid colder sticking surfaces than + 10°C, because in this case the adhesive becomes too hard and perhaps a sufficient immediate adhesion is hardly to achieve. After proper sticking, the stability of the connection is ensured also when the temperature is below zero. The final tackiness of a sticking is from experience reached after approximately 72 hours (at + 21° C). For gluing use only the supplied adhesive tape.

7.2.4 Cutting and Gluing

Before starting the gluing process, both the magnetic and the cover tape have to be cut to the required length

$$\text{Length cover tape} = \text{measuring length} + \text{sensor length} + 50\text{mm (end caps)}$$



NOTE!

When sticking the magnetic tape pay attention to the markings on the tape and the Sensor. Improper installation does not provide the correct values. A already glued magnetic tape is destroyed after the removal, and cannot be used again. Note also the direction of counting of the measuring system.

Preferably the magnetic tape should be glued close to an edge or into a groove, which should be deep enough to embed the magnetic tape and the cover tape.

When unprotected, the cover tape may peel off!

Therefore: Use tape end caps (☞ 9.1) or let the cover tape overlap the end of the magnetic tape and fix it with a screw.

The tape must be glued smoothly on the surface. The measuring accuracy decreases if the tape is not even!

Before gluing the magnetic tape and the cover tape onto the surface, they should be left lying on the mounting surface for ca. 30 minutes so that the temperature matches. This prevents strain in the tape due to thermal expansion.

Mounting steps:

1. Thoroughly clean the surface (☞ 7.2.3)
2. Acclimatization: let magnetic tape and cover tape adjust their temperature
3. Remove the protection foil from the magnetic tape
4. Glue magnetic tape under great pressure
5. Thoroughly clean surface of magnetic tape
6. Remove the protection foil from the cover tape
7. Glue the cover tape under great pressure
8. Safeguard the ends of the cover tape against peeling off, e.g. by using end caps (☞ 9.1)

7.2.1 Resistance against Chemical Influence

Table 1: Resistance against Chemical Influence

Show no or little effect in constant contact after 2-5 years:

formic acid	glycerol 93°C	linseed oil	soy beans oil
cotton seed oil	N-hexane	lactic acid	
formaldehyde 40%	Iso octane	petroleum	

Show weak to moderate effects in constant contact after approximately 1 year:

acetone	gasoline	acetic acid 30%	oleic acid
acetylene	steam	acetic acid, pure acetic acid	sea water
ammonia	acetic acid 20%	isopropyl ether	stearic acid 70°C, anhydrous
kerosene			

Have strong effects when contacting permanently after 1-5 months:

benzene	nitric acid 70%	turpentine	toluene
lacquer solvent	nitric acid, red, vitriolic	carbon tetrachloride	tetrahydrofuran
trichloroethylene	nitrobenzene	hydrochloric acid 37%, 93°C	xylene

7.3 Mounting the Sensor Head

To mount the sensor head, use 2 x M3 screws of adequate length.

- see also section 6.2 Sensor Dimensions

During installation, the specified installation tolerances must also be adhered to:

7.3.1 Mounting Tolerances

Table 2: Mounting tolerances

Magnetic tape	MB20-50-10-1-R
Sensor distance to the tape:	max. 4.0 mm
Lateral offset:	± 1 mm
Tilt and pitch angle:	$\pm 5^\circ$
Yaw angle:	$\pm 1.5^\circ$

Sensor distance:

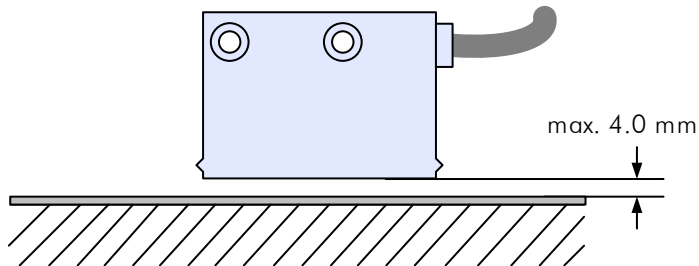

Lateral offset:

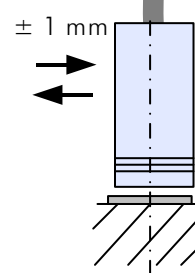

Pitch angle:

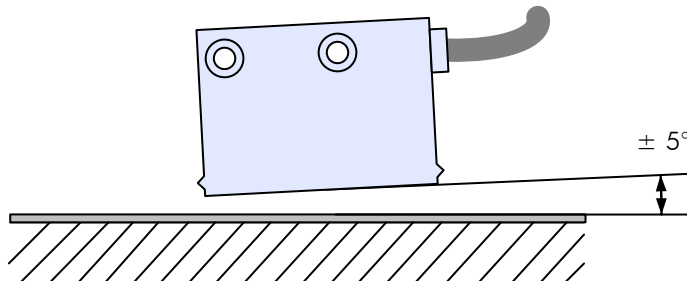

Tilt angle:

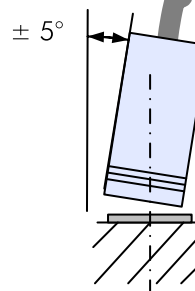

Yaw angle:

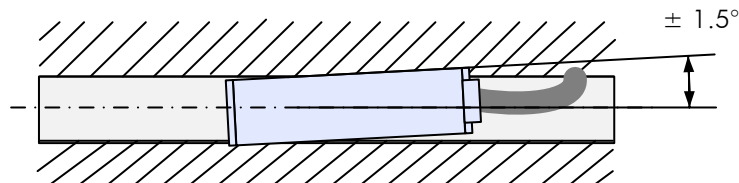
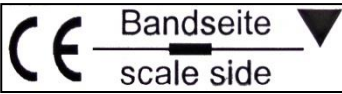

Figure 7: Mounting tolerances

7.4 Mounting Direction



On the underside of the sensor there is a sticker which signals the magnetic tape side with the active sensor areas. In addition, the ▼-marking indicates the positive counting direction.

7.5 Alignment of the Sensor to the Magnetic Tape

For linear applications with a magnetic tape, the center of the sensor is aligned to the center of the magnetic tape. Both active sensor areas (see red hatched surfaces in the figure below) must be guided over the tape at the permitted distance up to a maximum of 4.0 mm.

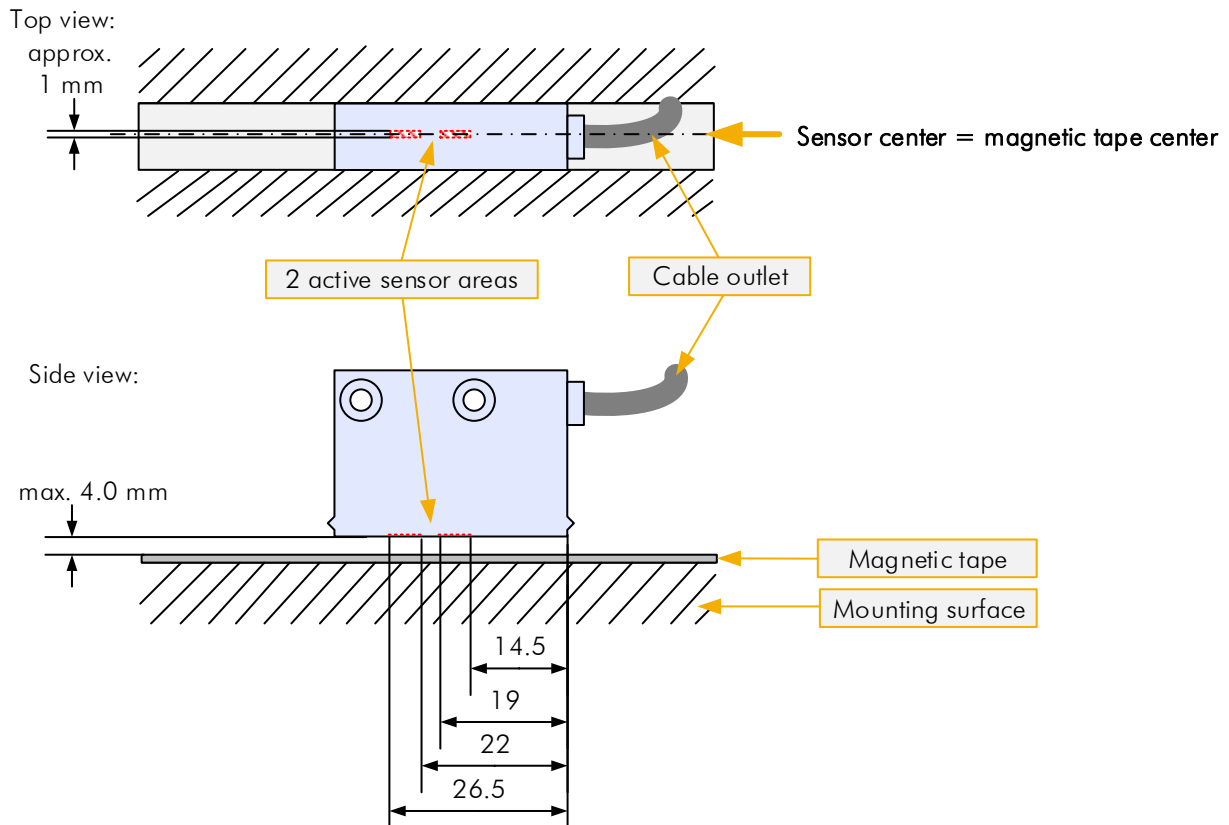

Figure 8: Alignment of the sensor to the magnetic tape



NOTE!

Please make sure that the mounting tolerances (see section 7.3.1) are observed.

7.6 Alignment of the Sensor to the Magnetic Ring

For rotative or radial applications with a magnetic ring, the diameter of the ring must be large enough so that both active sensor areas (see red hatched surfaces in the figure below) are within the permitted mounting distance of max. 4.0 mm. For this purpose, the center between the distance of both sensor surfaces and the center of the magnetic ring has to be aligned (see side view below - dimension 20.5 mm). Viewed from above, the center of the sensor must be aligned to the center of the magnetic tape (see top view).

Side view:

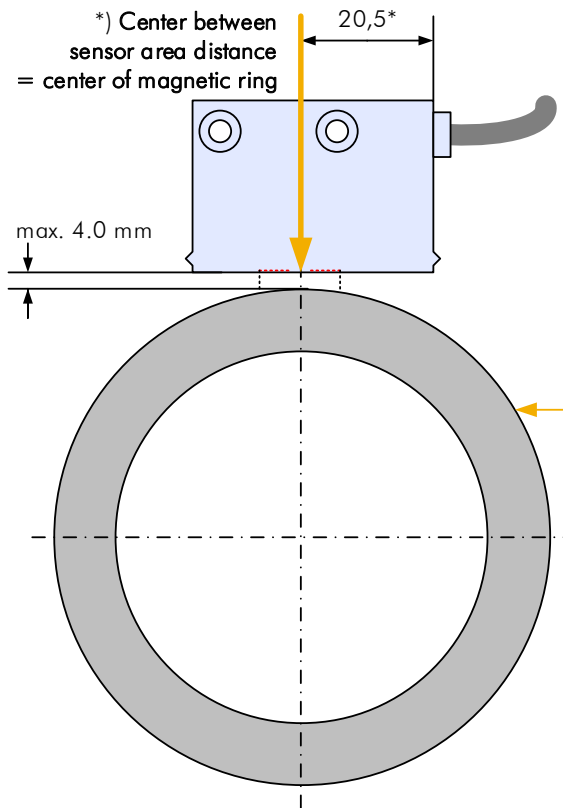

Top view:

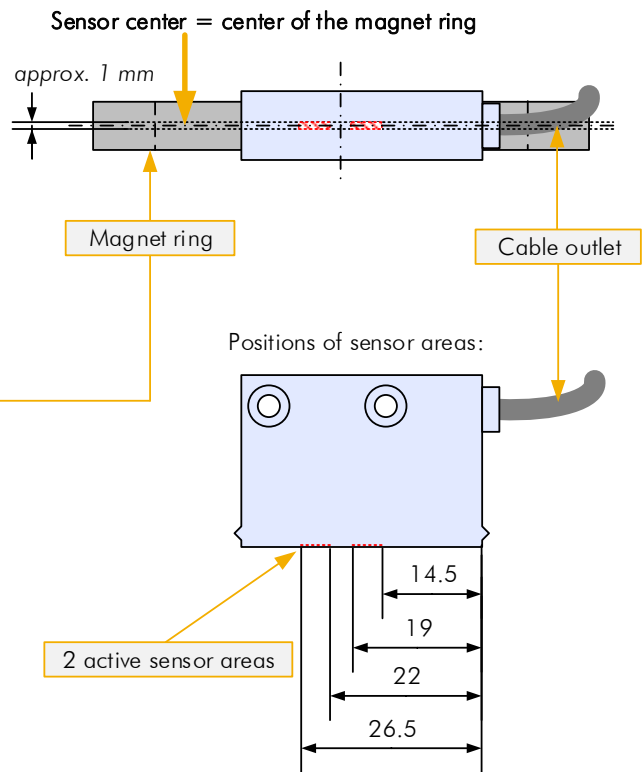

Figure 9: Alignment of the sensor to the magnetic ring

Available magnet rings can be found in section 9.1 Accessories.



NOTE!

Please make sure that the mounting tolerances (see section 7.3.1) are observed.

7.7 Connections

The GMIX2 measuring system is connected via open cable ends according to the following table:

Table 3: Pin assignment of the open cable ends

Type of connection	Color	Function	Description
Open cable ends	Black	0 V / GND	Ground
	Brow	10 ... 30 VDC	Voltage supply
	Red	A	Channel A
	Orange	B	Channel B
	Blank	Screen	Screen/Shield

8 Disturbances, Maintenance, Cleaning

This chapter describes possible causes for disturbances and measures for their removal. In case of increased disturbances, please follow the measures for fault clearance in chapter 8.1. In case of disturbances that cannot be eliminated by following the advice and the fault clearance measures given here, please contact the manufacturer (see second page).

8.1 Fault Clearance



CAUTION!

The device, the connection line and the signal cable must not be installed next to sources of interference that emit strong inductive or capacitive interference or strong electrostatic fields.

External perturbations can be avoided thorough suitable cable routing.



The screen of the signal output cable should only be connected to the following circuit on one side. The screens should not be grounded on both sides. Signal cables always have to be routed separately from the load power line. A safety distance of at least 0.5 m has to be kept from inductive and capacitive sources of interference such as contactors, relays, motors, switching power supplies, clocked controllers etc.!

If interferences occur in spite of all the items stated above being observed, please proceed as follows:

1. Installation of RC-circuits via contactor coils of AC-contactors (e.g. 0.1 μ F / 100 Ω)
2. Installation of recovery diodes via DC-inductors
3. Installation of RC-circuits via the different motor phases (in the terminal box of the motor)
4. Do not connect protective earth and ground
5. Connect a mains filter ahead of the external power pack

8.2 Re-start after Fault Clearance

After the fault clearance:

1. Reset the emergency stop mechanism if necessary
2. Reset the error report at the super-ordinate system if necessary.
3. Ensure that there are no persons in the danger area.
4. Follow the instructions from chapter 7.



WARNING! Danger of injury through non-conventional fault clearance!

Non-conventional fault clearance can lead to severe injuries and damage of property. Therefore:

- Any work to clear the faults may only be performed by sufficiently qualified staff
- Arrange enough space before starting the works
- Make sure that the mounting area is clean and tidy. Loose components and tools are sources of accidents.

If components need to be replaced:

- Pay attention to a correct installation of the spare parts.
- Reinstall all the fixing elements properly
- Before turning on the device, ensure that all covers and safety equipment is installed correctly and functions properly

8.3 Maintenance

The device is maintenance-free.

8.4 Cleaning



WARNING!

The device can only be cleaned with a damp cloth, do not use aggressive cleanser!

9 Type Designation

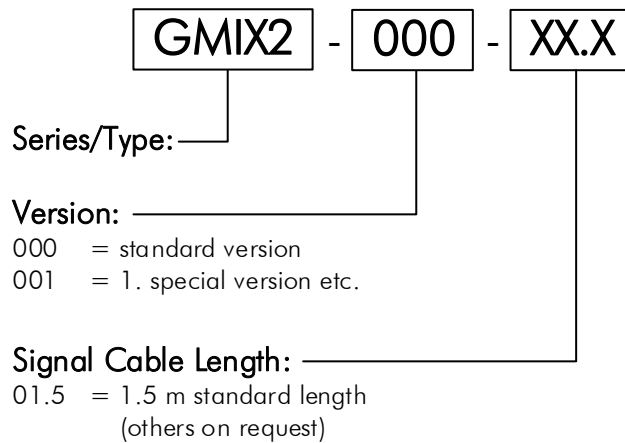

NOTE

When ordering, please use the here described ordering code (Type Designation). Options that are not required are filled in with „-“.

9.1 Accessories

Table 4: Accessories

Order Designation	Description
MB20-50-10-1-R	Magnetic tape with 5 mm pole pitch (please indicate length in XX.X m)
10 mm end cap set	2 end caps (10 mm) for magnetic tape. Two M3 screws included. Additional fixation in the radial and linear range to protect the ends of the magnetic tape.
FS1000, FS1500 or FS2000	Guide rail for magnetic tape (length: 1.0 m, 1.5 m and max. 2.0 m available). For longer measuring lengths the rails can be lined up together.
AP-00-XX**	Aluminium cover-profile for magnetic tapes (as alternative to the cover tape). **) AP-00-1m = 1m long / AP-00-2m = 2 m long
MR2012	Magnet ring ($\varnothing_o = 19,75 \text{ mm} / \varnothing_i = 14.7 \text{ mm}$, $w = 4.1 \text{ mm}$, 12 poles, $IF = 2$)
MR3824	Magnet ring ($\varnothing_o = 38 \text{ mm} / \varnothing_i = 30 \text{ mm}$, $w = 6,5 \text{ mm}$, 24 poles, $IF = 200$)
MR7244	Magnet ring ($\varnothing_o = 72 \text{ mm} / \varnothing_i = 54 \text{ mm}$, $w = 7 \text{ mm}$, 44 poles, $IF = 500$)
POSU	Pole finder card 85 x 55 mm

Notes:

Notes:

10 Index

Accessories	22	Operating area	13
Accident prevention regulations.....	5	Operational safety.....	5
Causes of risk.....	6	Order reference	9
Cleaning.....	21	Packaging material.....	7
Connections	20	Product Features	8
Conventional use.....	7	Protection against contact	13
Demounting	6	Protective equipment	6
Device number	9	Pulse Diagram	8
DIL Switch Settings	18	Safety	5, 6
Dimensions of Evaluation Box	9	Safety instructions	5
Dimensions of Sensor.....	9	Safety rules	5
Disposal.....	6	Set Operating Direction of VMAX.....	18
Disturbances	21	Set Resolution	18
Enable/Disable Speed Monitoring VMAX	18	Setting the Output Levels.....	18
Explanation of symbols.....	5	Signal LEDs.....	19
Fault clearance.....	21	Speed monitoring.....	18, 19
First start-up	13	Start-up	13
Flashing Sequences (Green Status LED)	19	Storage	7
Functional Principle.....	8	Technical Data Magnetic Tape	12
Identification	9	Technical Data Sensor	11
Installation	13	Transport	7
Magnetic tape structure	12	Transport damage	7
Maintenance	21	Type designation	9
Mounting the Evaluation Box	14	Type Designation	22
Mounting the Sensor Head	14	VMAX output.....	19
Mounting Tolerances	14		

Document- No.: 799000019 / Rev. 0
Document- Name: GMIX2-000-MA-E_39-19
Subject to change - © 2019
ELGO Electronic GmbH & Co. KG

ELGO Electronic GmbH & Co. KG
Measuring | Positioning | Control
Carl - Benz - Str. 1, D-78239 Rielasingen
Fon: +49 (0) 7731 9339-0, Fax: +49 (0) 7731 28803
Internet: www.elgo.de, Mail: info@elgo.de

