

Operating Manual

SERIES RMAX1

Magnetic Single-Turn Absolute Encoder for Angular Measurement Applications

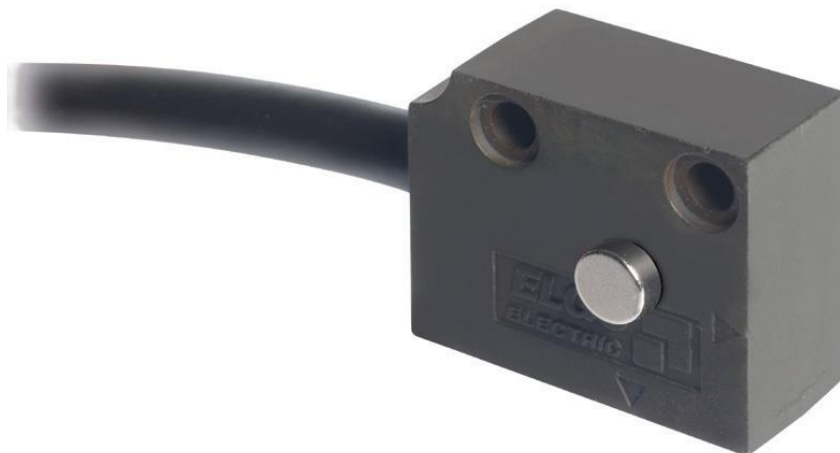

- Usable with round magnet type DRM-000-060-025
- Resolution of 12 bit over the entire measuring distance
- Interface: Analog 0.5 ... 4.5 V or PWM $f = 200$ Hz
- Direct measurement at the engine shaft or the axis possible
- No abrasion due to contactless measuring principle

Publisher ELGO Electronic GmbH & Co. KG
Carl-Benz-Str. 1
D-78239 Rielasingen-Worblingen

Technical Support  +49 (0) 7731 9339 - 0
 +49 (0) 7731 2 88 03
 info@elgo.de

Document- No. 799000677

Document- Name RMAX1-000-MA-E_38-20

Document- Revision Rev. 5

Issue Date 2020-09-17

Copyright © 2020, ELGO Electronic GmbH & Co. KG

1 Contents

1	Contents	3
2	General, Safety, Transport and Storage	4
2.1	Information Operating Manual	4
2.2	Explanation of Symbols	4
2.3	Statement of Warranties	5
2.4	Demounting and Disposal	5
2.5	General Causes of Risk.....	5
2.6	Personal Protective Equipment.....	5
2.7	Conventional Use	6
2.8	Safety Instructions for Transport, Unpacking and Loading	6
2.9	Handling of Packaging Material	6
2.10	Inspection of Transport	6
2.11	Storage	6
3	Product Features	7
4	Technical Data	7
4.1	Identification	7
4.2	Dimensions Sensor.....	7
4.3	Dimensions Round Magnet.....	7
4.4	Technical Data Sensor	8
5	Installation and First Start-Up.....	9
5.1	Operating Area	9
5.2	Mounting Sensor and Round Magnet	10
6	Functionality.....	11
6.1	Connections and Interfaces	11
7	Disturbances, Maintenance, Cleaning.....	13
7.1	Fault Clearance.....	13
7.2	Re-start after Fault Clearance.....	13
7.3	Maintenance.....	13
7.4	Cleaning	13
8	Type Designation	14
8.1	Accessories	14
9	Index	15

2 General, Safety, Transport and Storage



2.1 Information Operating Manual

This manual contains important information regarding the handling of the device. For your own safety and operational safety, please observe all safety warnings and instructions. Precondition for safe operation is the compliance with the specified safety and handling instructions. Moreover, the existing local accident prevention regulations and the general safety rules at the site of operation have to be observed. Please read the operating manual carefully before starting to work with the device! It is part of the product and should be kept close to the device and accessible for the staff at any time. The illustrations in the manual are for better demonstration of the facts. They are not necessarily to scale and can slightly differ from the actual design.

2.2 Explanation of Symbols

Special notes in this manual are characterized by symbols. The notes are introduced by signal words which express the magnitude of danger. Please follow this advice and act carefully in order to avoid accidents, damage, and injuries.

Warning notes:

	DANGER! This symbol in connection with the signal word "Danger" indicates an immediate danger for the life and health of persons. Failure to heed these instructions can result in serious damage to health and even fatal injury.
	WARNING! This symbol in connection with the word „Warning“ means a possibly impending danger for the life and health of persons. Failure to heed these instructions can result in serious damage to health and even fatal injury.
	CAUTION! This symbol in connection with the signal word "Caution" indicates a possibly dangerous situation. Failure to heed these instructions can lead to minor injuries or damage of property.



Special safety instructions:

	DANGER! This symbol in connection with the signal word "Danger" indicates an immediate danger for the life and health of persons due to voltage. Failure to heed these instructions can result in serious damage to health and even fatal injury. The operations may only be carried out by a professional electrician.
---	---

Tips and recommendations:

	NOTE! ...points out useful tips and recommendations as well as information for an efficient and trouble-free operation.
---	---

Reference marks:

-  Marks a reference to another chapter of this manual.
-  Marks a reference to another chapter of another document.

2.3 Statement of Warranties

The producer guarantees the functional capability of the process engineering and the selected parameters.

2.4 Demounting and Disposal

Unless acceptance and disposal of returned goods are agreed upon, demount the device considering the safety instructions of this manual and dispose it with respect to the environment.

Before demounting disconnect the power supply and secure against re-start. Then disconnect the supply lines physically and discharge remaining energy. Remove operational supplies and other material.

Disposal: Recycle the decomposed elements: Metal components in scrap metal, Electronic components in electronic scrap, Recycle plastic components, dispose the remaining components according to their material consistence.



CAUTION!

Wrong disposal causes environmental damages! Electronic scrap, electronic components, lubricants and other auxiliary materials are subject to special refuse and can only be disposed by authorized specialists!

Local authorities and waste management facilities provide information about environmentally sound disposal.

Safety



CAUTION!

Please read the operating manual carefully, before using the device! Observe the installation instructions! Only start up the device if you have understood the operating manual. The operating company is obliged to take appropriate safety measure. The initial operation may only be performed by qualified and trained staff.

Selection and installation of the devices as well as their embedding into the controlling system require qualified knowledge of the applicable laws and normative requirements on the part of the machine manufacturer.

2.5 General Causes of Risk



This chapter gives an overview of all important safety aspects to guarantee an optimal protection of employees and a safe and trouble-free operation. Non-observance of the instructions mentioned in this operating manual can result in hazardous situations.

2.6 Personal Protective Equipment

Employees have to wear protective clothing during the installation of the device to minimize danger of health.

Therefore: Change into protective clothing before performing the works and wear them throughout the process. Additionally observe the labels regarding protective clothing in the operating area.

Protective clothing:

	<p>PROTECTIVE CLOTHING ... is close-fitting working clothing with light tear strength, tight sleeves and without distant parts. It serves preliminarily for protection against being gripped by flexible machine parts. Do not wear rings, necklaces or other jewellery.</p>
	<p>PROTECTIVE GLOVES ...for protecting the hands against abrasion, wear and other injury of the skin.</p>
	<p>PROTECTIVE HELMET ...for protection against injuries of the head.</p>

2.7 Conventional Use

The ELGO-device is only conceived for the conventional use described in this manual.
The ELGO absolute encoder RMAX1 is used exclusively for rotative application, e.g. for angular measurement.



CAUTION!

Danger through non-conventional use!
Non-intended use and non-observance of this operating manual can lead to dangerous situations.
Therefore:

- Only use the device as described
- Strictly follow the instructions of this manual

Avoid in particular:

- Remodelling, refitting or changing of the construction or single components with the intention to alter the functionality or scope of the device.

Claims resulting from damages due to non-conventional use are not possible.
Only the operator is liable for damages caused by non-conventional use.

2.8 Safety Instructions for Transport, Unpacking and Loading



CAUTION!

Transport the package (box, palette etc.) professionally. Do not throw, hit or fold it.

2.9 Handling of Packaging Material

Notes for proper disposal: ↗2.4

2.10 Inspection of Transport

Check the delivery immediately after the receipt for completeness and transport damage.
In case of externally recognizable transport damages:

- Do not accept the delivery or only accept under reserve.
- Note the extent of damages on the transportation documents or delivery note.
- File complaint immediately.



NOTE!

Claim any damage immediately after recognizing it. The claims for damage must be filed in the lawful reclaim periods.

2.11 Storage

Store the device only under the following conditions:

- Do not store outside
- Keep dry and dust-free
- Do not expose to aggressive media
- Protect from direct sun light
- Avoid mechanical shocks
- Storage temperature (↗ 4.4) needs to be observed
- Relative humidity (↗ 4.4) must not be exceeded
- Inspect packages regularly if stored for an extensive period of time (>3 months)

3 Product Features

The angle measuring system RMAX1 is a combination of a sensor and a round magnet type DRM-000-060-025 (not included in delivery). The encoder is used for rotative angle measurement. The round magnet can be mounted directly on an axis (for example on a drive shaft).

Overview of features:

- Rotative measuring system
- 12 bit resolution
- Interfaces: Analog 0.5 ... 4.5 V or PWM
- Direct measuring at the engine shaft or the axis possible
- No abrasion through contactless measuring principle

4 Technical Data

4.1 Identification

The type label serves for the identification of the unit. It is located on the housing of the sensor and gives the exact type designation (=order reference, see § 8) with the corresponding part number. Furthermore, the type label contains a unique, traceable device number. When corresponding with ELGO always indicate this data.

4.2 Dimensions Sensor

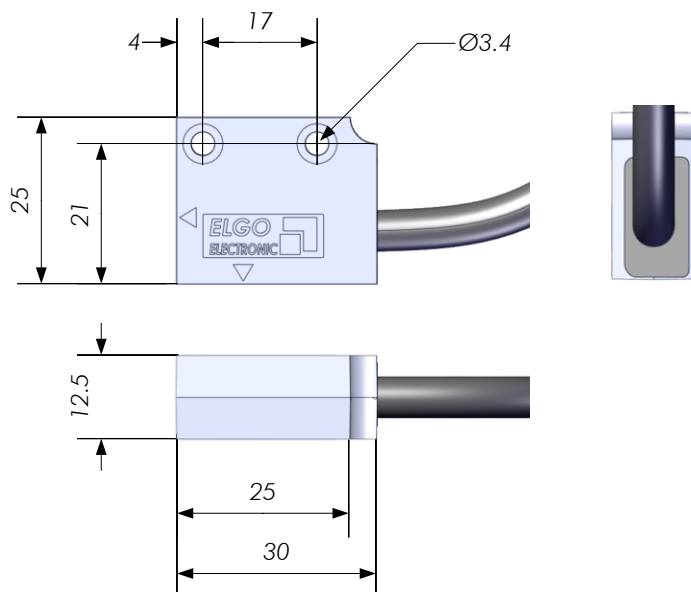

Figure 1: Dimensions housing

4.3 Dimensions Round Magnet

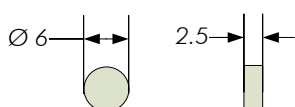

Figure 2: Round magnet DRM

4.4 Technical Data Sensor

RMAX1 (Standard version)

Mechanical Data

Measuring principle	absolute - rotative
Distance sensor - round magnet	1 ... 3 mm
Sensor housing material	zinc die-cast, black
Sensor dimensions (without cable)	L x W x H = 30 x 12.5 x 25 mm
Required round magnet type	DRM-000-060-025 (Ø 6 mm)
Magnetic field strength	30 mT ... 70 mT
Angular measuring range	analog version: 0 ... 360° PWM version : 0 ... 270°, f = 200 Hz (other ranges on request)
Connections	open cable ends (standard)
Sensor cable	1.5 m standard cable length (others on request), drag chain suitable
Sensor cable bending radius	min. 60 mm
Weight	approx. 40 g without cable; cable approx. 60 g per meter

Electrical Data

Power supply voltage	+5 VDC (± 100 mV)
Residual ripple	< 25 mVpp
Reverse polarity protection	no reverse polarity protection!
Consumption	analog version: max. 10 mA PWM version: max. 15 mA
Interfaces:	analog output 0.5 ... 4.5 V or PWM f = 200 Hz
Protection (outputs / interfaces):	not short-circuit-proof
Resolution	12 Bit \cong 4096 measuring steps per revolution

Conditions

Storage temperature	-20 ... +85 °C
Operation temperature	-10 ... +70 °C (-25 ... +85 °C upon request)
Humidity	max. 95 %, non-condensing
Protection class	IP67

5 Installation and First Start-Up



CAUTION

Please read the operating manual carefully before using the device! Strictly observe the Installation instructions! In case of damage caused by failure to observe this operating manual, the warranty expires.

ELGO is not liable for any secondary damage and for damage to persons, property or assets.

The operator is obliged to take appropriate safety measures.

The first start-up may only be performed by staff that has been trained and authorized by the operator.

5.1 Operating Area



WARNING!

Do not use the device in explosive or corrosive environments! The device must not be installed close to sources of strong inductive or capacitive interference or strong electrostatic fields!



CAUTION!

The electrical connections must be made by suitably qualified personnel in accordance with local regulations.



The device may be designed for switchboard mounting. During work on the switchboard, all components must be de-energized if there is a danger of touching the energized parts! (protection against contacts)

Wiring works may only be performed in the de-energized state!



Thin cable strands have to be equipped with end sleeves!

Before switching on the device, connections and plug connectors have to be checked!



The device must be mounted in a way that it is protected against harmful environmental influences such as splashing water, solvents, vibration, shock and severe pollution and the operating temperature must not be exceeded.

5.2 Mounting Sensor and Round Magnet



NOTE!

The round magnet must be ordered separately! Order number: DRM-000-060-025



Round magnet DRM-000-060-025

The round magnet has a diameter of 6 mm and a height of 2.5 mm. One of the two sides must be aligned as shown in figure 2 (see 4.2). Since there is no upper side defined, it does not matter which side of the magnet is adjusted to the sensor.

5.2.1 Round magnet distance:

The perfect distance between round magnet (Magnetisation force 30 mT ... 70 mT) and active sensor area of the measuring system is 1 ... 3 mm. Out of this range the accuracy cannot be guaranteed.

5.2.2 Fixation of the magnet:

The magnet can either be glued or for example be bedded directly in a shaft or a guiding system, as long as they are made out of non-magnetic steel such as V2A, V4A high-grade steel or aluminium. The magnet and the bonding surface must be clean and greaseless before gluing the parts together. When gluing on plastic it is advisable to rub the plastic with fine sandpaper.

Suitable adhesives are: LOCTITE 405 (viscosity: liquid, curing in about one minute) LOCTITE 409 (viscosity: jellylike, curing in about two minutes).

5.2.3 Round magnet - alignment and tolerances:

The figure below shows the correct alignment of the round magnet to the sensor:

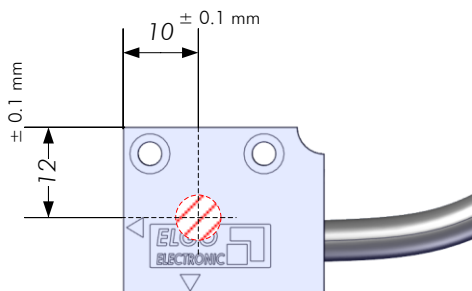

Figure 3: Alignment of the magnet to sensor

In order to guarantee a perfect function the determined position and tolerances must be exactly adhered to.

See (see 4.2) to find the dimensions of the sensor and the round magnet

6 Functionality

With a full rotation of the magnet (360°) the sensor provides an analog voltage of 0.5 ... 4.5V or a PWM signal with a pulse width of 10 ... 90 % (Range 270°).

6.1 Connections and Interfaces

6.1.1 Power Supply

+5 VDC (± 100 mV)

6.1.2 Analog Interface 0.5 ... 4.5 V

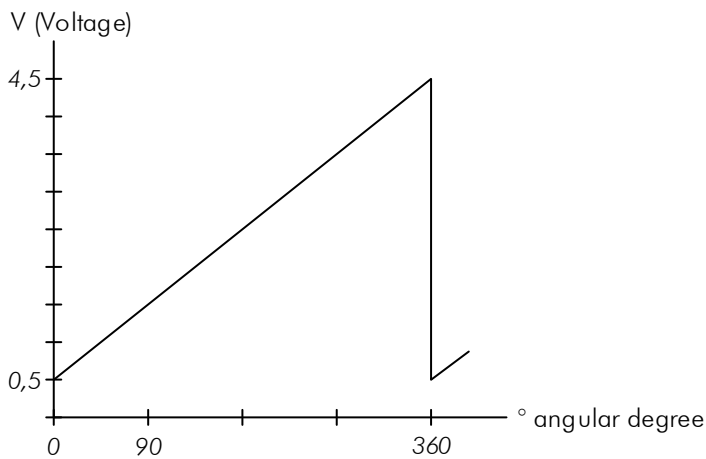

Figure 4: Output signal analog

6.1.3 PWM Interface

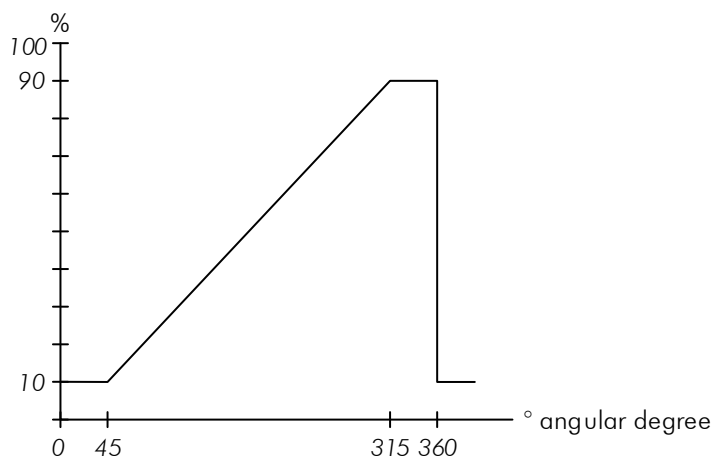

Figure 5: Output signal PWM

6.1.4 Pin Assignment

6.1.4.1 Analog Interface

Table1: Pin Assignment analog Interface, open cable end

Colour	Function
White	0 V / GND
Brown	+5 VDC
Green	Analog output
Blank	Shield

6.1.4.2 PWM Interface

Table2: Pin Assignment PWM Interface, open cable end

Colour	Function
White	0 V / GND
Brown	+5 VDC
Green	PWM output
Blank	Shield

7 Disturbances, Maintenance, Cleaning

This chapter describes possible causes for disturbances and measures for their removal. In case of increased disturbances, please follow the measures for fault clearance in chapter 7.1. In case of disturbances that cannot be eliminated by following the advice and the fault clearance measures given here, please contact the manufacturer (see second page).

7.1 Fault Clearance



CAUTION!

The device, the connection line and the signal cable must not be installed next to sources of interference that emit strong inductive or capacitive interference or strong electrostatic fields.

External perturbations can be avoided through suitable cable routing.



The screen of the signal output cable should only be connected to the following circuit on one side. The screens should not be grounded on both sides. Signal cables always have to be routed separately from the load power line. A safety distance of at least 0,5 m has to be kept from inductive and capacitive sources of interference such as contactors, relays, motors, switching power supplies, clocked controllers etc.!

If interferences occur in spite of all the items stated above being observed, please proceed as follows:

1. Installation of RC-circuits via contactor coils of AC-contactors (e.g. 0,1 μ F / 100 Ω)
2. Installation of recovery diodes via DC-inductors
3. Installation of RC-circuits via the different motor phases (in the terminal box of the motor)
4. Do not connect protective earth and ground
5. Connect a mains filter ahead of the external power pack

7.2 Re-start after Fault Clearance

After the fault clearance:

1. Reset the emergency stop mechanism if necessary
2. Reset the error report at the super-ordinate system if necessary.
3. Ensure that there are no persons in the danger area.
4. Follow the instructions from chapter 5.



WARNING! Danger of injury through non-conventional fault clearance!

Non-conventional fault clearance can lead to severe injuries and damage of property.

Therefore:

- Any work to clear the faults may only be performed by sufficiently qualified staff
- Arrange enough space before starting the works
- Make sure that the mounting area is clean and tidy. Loose components and tools are sources of accidents.

If components need to be replaced:

- Pay attention to a correct installation of the spare parts.
- Reinstall all the fixing elements properly
- Before turning on the device, ensure that all covers and safety equipment is installed correctly and functions properly

7.3 Maintenance

The device operates maintenance-free.

7.4 Cleaning



WARNING!

The device can only be cleaned with a damp cloth, do not use aggressive cleanser!

8 Type Designation

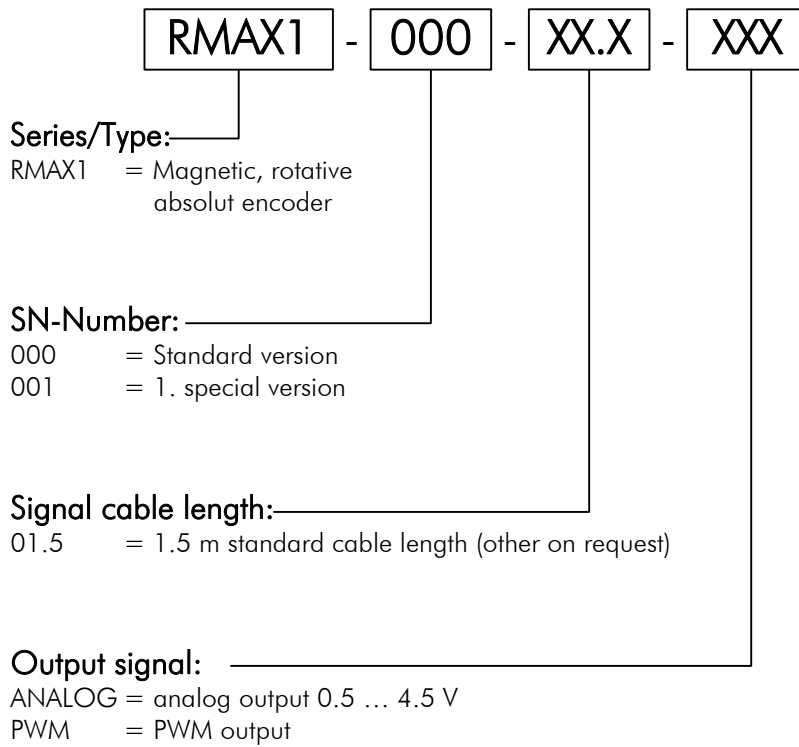

NOTE

When ordering, please use the here described ordering code (Type Designation). Options that are not required are filled in with „-“.

8.1 Accessories

Table 3: Accessories

Order Designation	Description
DRM-000-060-025	Round magnet (diameter 6 mm, height 2.5 mm)

9 Index

Accessories	14	Mounting Sensor and Round Magnet	10
Accident prevention regulations.....	4	Operating area	9
Causes of risk.....	5	Operational safety.....	4
Cleaning.....	13	Order reference	7
Connections	11	Packaging material.....	6
Conventional use.....	6	Pin Assignment	12
Demounting	5	Power Supply	11
Device number	7	Protection against contact	9
Dimensions Round Magnet.....	7	Protective equipment	5
Dimensions Sensor.....	7	Round magnet - alignment and tolerances:	10
Disposal.....	5	Round magnet distance:	10
Disturbances	13	Safety	4, 5
Explanation of symbols.....	4	Safety instructions	4
Fault clearance.....	13	Safety rules	4
First start-up	9	Start-up	9
Fixation of the magnet:	10	Storage	6
Functionality	11	Technical Data Sensor	8
Identification	7	Transport.....	6
Installation	9	Transport damage.....	6
Interfaces	11	Type designation	7
Maintenance	13	Type Designation	14

Document- No.: 799000677 / Rev. 5
Document- Name: RMAX1-000-MA-E_38-20
Subject to change - © 2020
ELGO Electronic GmbH & Co. KG

ELGO Electronic GmbH & Co. KG
Measuring | Positioning | Control
Carl - Benz - Str. 1, D-78239 Rielasingen
Fon: +49 (0) 7731 9339-0, Fax: +49 (0) 7731 28803
Internet: www.elgo.de, Mail: info@elgo.de

