

EMSC1/EMSC3 series

preliminary datasheet with attached short manual

magnetic linear encoder

with 1 Volt (peak to peak) sine/cosine-outputs

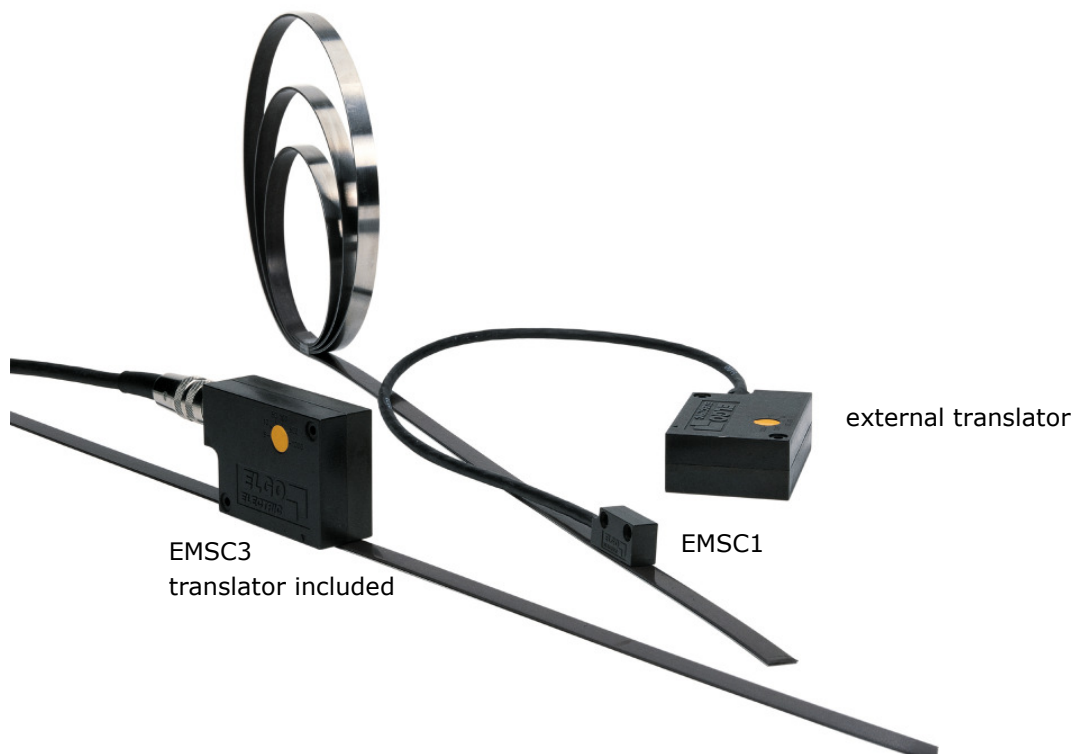

Only functional with an ELGO MB20.20 magnetic tape (2 mm pole distance)!

- **speed proportional sine/cosine-wave outputs**
- **abrasion resistant measuring principle**
- **2 mm's movement results in one sine/cosine period**
- **distance to the tape up to 0.8 mm's possible**
- **two different available housing designs**

Representation of the signal forms

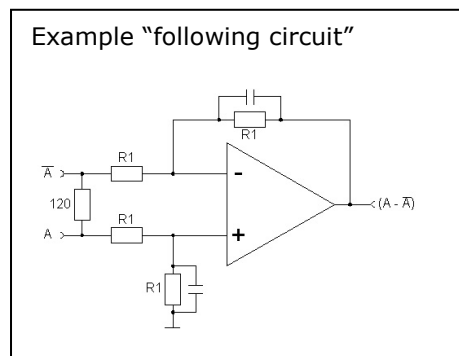
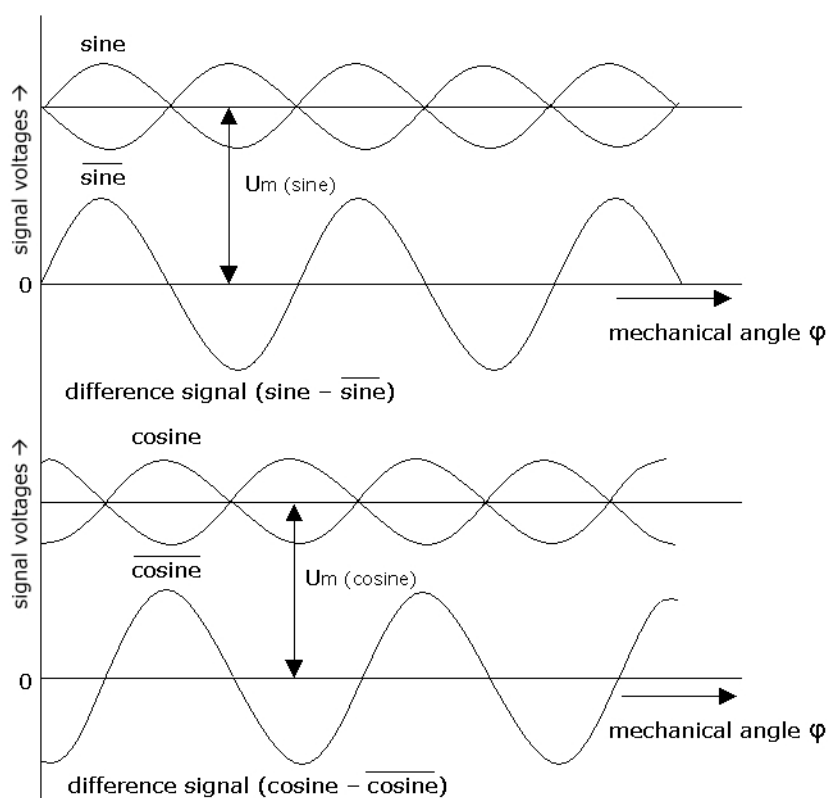

Technical specifications

Parameter	Designation	min.	typ.	max.	Unit
middle voltage	$U_m (\text{sine}), U_m (\text{cosine})$	2.4	2.5	2.6	V
amplitude	$\frac{\text{sine} - \overline{\text{sine}}}{\text{cosine} - \overline{\text{cosine}}}$	400	500	600	mV
relation	$\frac{(\text{sine} - \overline{\text{sine}})}{(\text{cosine} - \overline{\text{cosine}})}$	0.9	1.0	1.1	-
phase shift	φ	89	90	91	° grades
distortion factor	K	-	-	2	%

Supply voltages	:	5 VDC +/- 2.5 %, stabilized (ripple < 50 mV) or 10... 30 VDC stabilized (ripple max. 5 %)
Speed	:	max. 10m/sec
Protection class of sensor head	:	EMSC1 = IP67, EMSC3 = IP54
Operation temperature	:	0... 50° C
Store temperature	:	0... 70° C
Humidity	:	max. 80 % (none condensing)

Magnetic tape (accessories)

Pole distance	:	2 mm
Operation temperature	:	0... 60° C
Linear expansion coefficient	:	$16 \times 10^{-6} 1/K$
Bend radius	:	min. 150 mm's
Protection class	:	IP67

Assembly

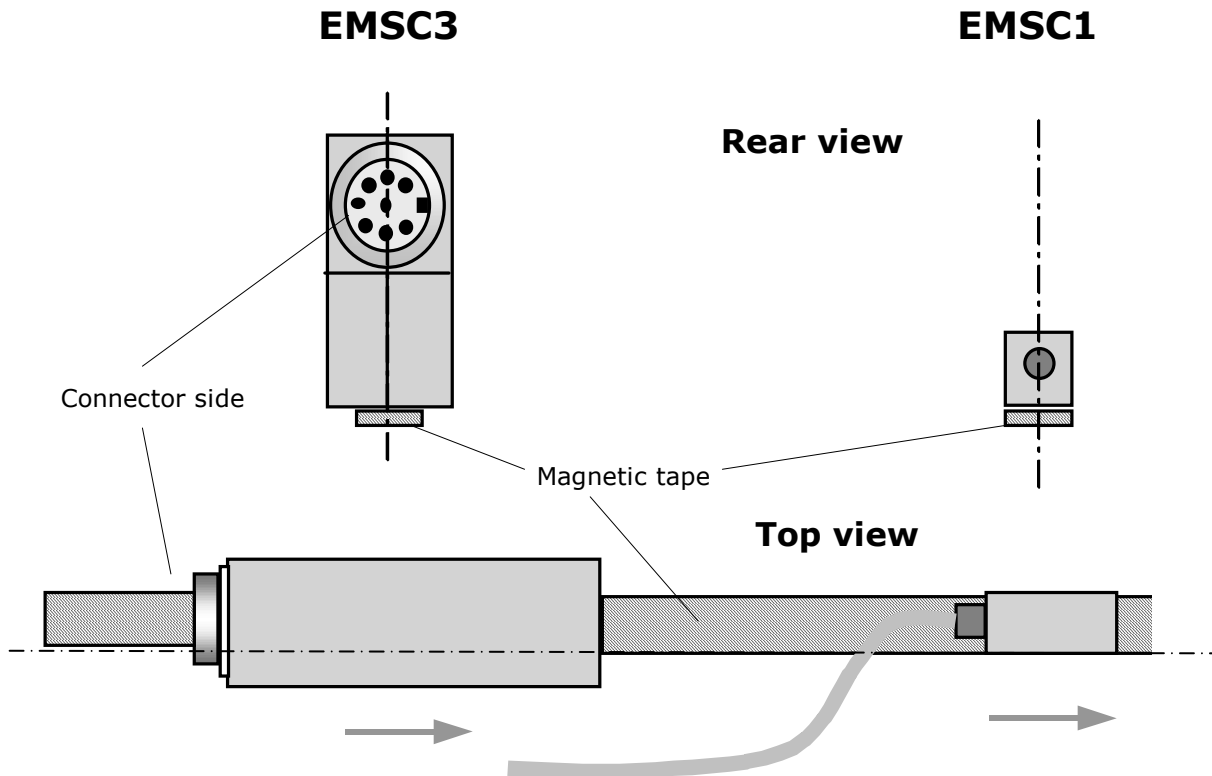

Mechanical data:

all housings	:	zinc die cast
dimensions	:	EMSC3 = 72 x 48 x 24 mm' s
(L x H x W)	:	EMSC1 = 72 x 48 x 24 mm' s translator case
		30 x 10 x 15 mm' s sensor head

Measurement of the EMSC 3 sensors resp- of the external translator (EMSC1)

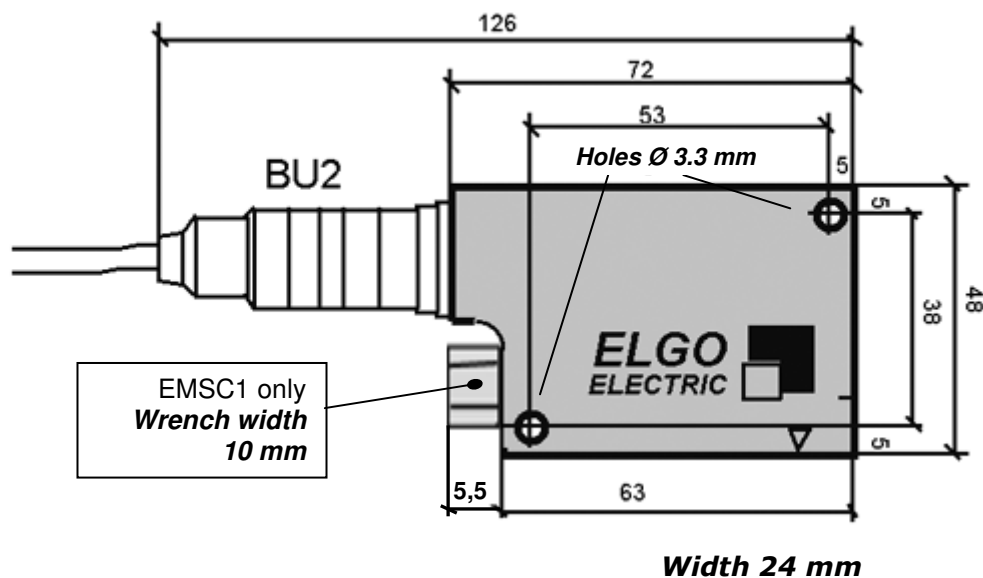

Dimensions of external sensor (EMSC1)

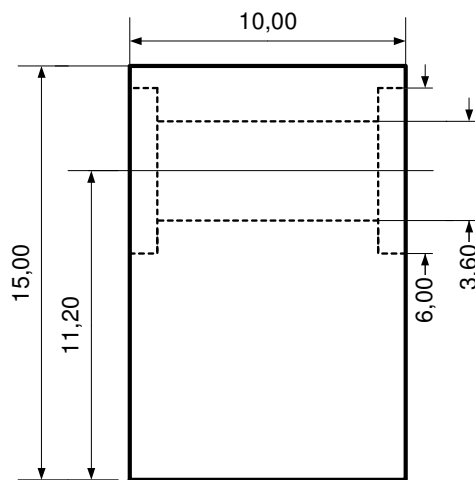
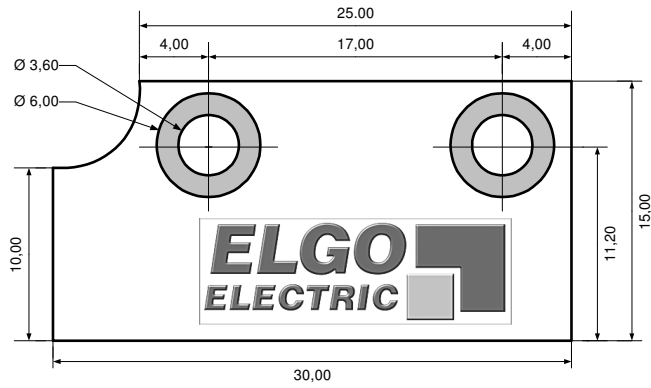

Installation, allowed rakes of the sensor
 applies to small external sensor (EMSC1) and large sensor (EMSC3)

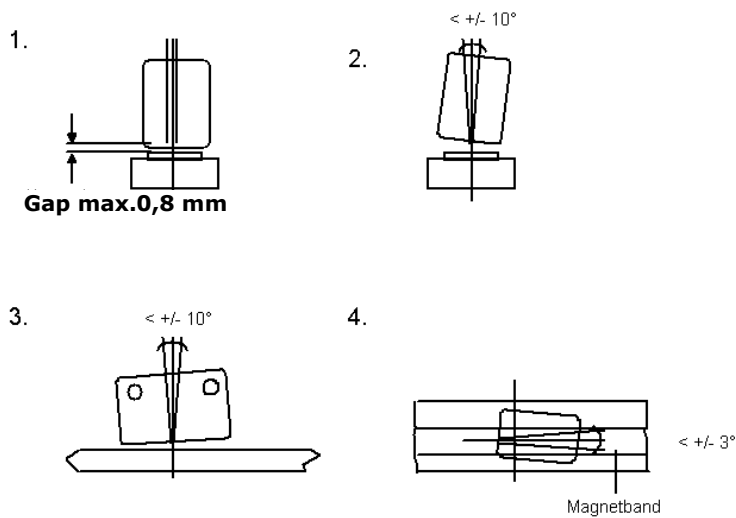

Connections / Pin assignment

8-pol. circular connector	conductor coloring	function
Pin 1	white	0V / GND
Pin 2	brown	10...30VDC
Pin 3	green	sine +
Pin 6	magenta	sine -
Pin 5	black	cosine +
Pin 8	grey	cosine -
Pin 4	N.C.	-
Pin 7	N.C.	-
case	blank	screen

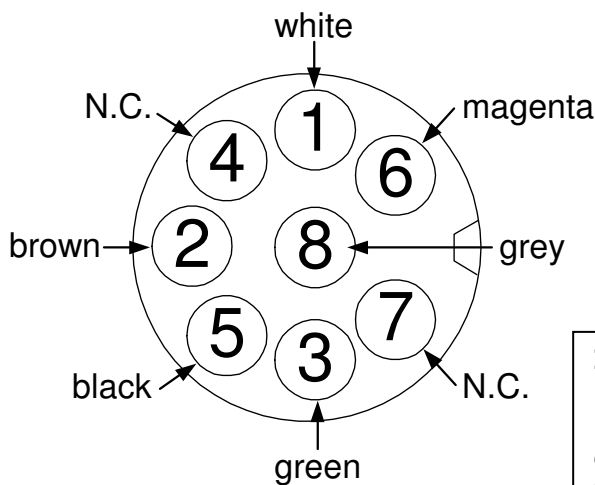
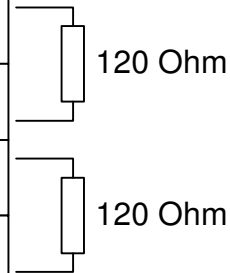

Important note: In case of using a Siemens PLC, the index input and/or also the inverted index input must be connected (PLC laterally) on a central level of 2.5 VDC. Otherwise the SPS will spent out an error message.

Sine and cosine pins must be closed with 120 Ohms

ELGO - Electric - GmbH
 Measure - Control - Position
 Carl - Benz - Straße 1, D-78239 Rielasingen
 phone.: 0049-7731/93 39 - 0, Fax: 2 88 03
 Internet: www.elgo.de, Mail: info@elgo.de



subject to modifications, © ELGO Electric GmbH 2005