

# Description

## ELGO PNO 1

### SSI / Profibus - Converter



- GSD- file is provided on cd-rom or disk
- also for not ELGO products applicable
- Profibus - interface after IEC61158/IEC61784
- SSI – interface 24Bit binär codiert + 1PFB
- supply voltage +19 to +27 VDC
- simple assembly
- intensive to contamination

<b>1. GENERAL</b>	<b>3</b>
<b>2. SECURITY</b>	<b>3</b>
2.1 screening measures	3
<b>3. ASSEMBLY OF THE CONVERTER</b>	<b>4</b>
<b>4. OPERATING PARAMENTER</b>	<b>4</b>
4.1 Attitudes	5
<b>5. EXTERNAL DIMENSIONS</b>	<b>6</b>
<b>6. INTERFACES AND MINUTES</b>	<b>7</b>
6.1 SSI - interface	7
6.2 Profi-Bus interface	8
<b>7. TECHNICAL DATA</b>	<b>9</b>
<b>8. MODEL CODE</b>	<b>9</b>
<b>9. ACCESSORIES</b>	<b>10</b>
<b>10. NON- LIABILITY/WARRANTY</b>	<b>11</b>

## 1. General

The ELGO Profibus – converter has on the one hand professional bus- interface, on the other hand over 24 bits, standardized after IEC61158/IEC61784, binary coded SSI- interface with power failure bit (PFB). The converter can be thus everywhere used, where equipment with SSI interface is to be attached to a professional bus.

Der ELGO Profibus – Converter bietet entscheidende Vorteile:

- even for older ELGO of devices with SSI - interface applicable
- is not suitable also for ELGO of products
- simple/problem-free conversion of SSI on professional bus
- up to 1200m conduit length
- transmission rate up to 12Mbaud
- insensitive to dirt (IP50 standard)
- simple assembly owing to assembly slots

## 2. Security



Note: Before first start-up this installation manual is to be read carefully and the installation hints is absolutely to be obeyed. The converter serves excluding the data conversion of SSI on professional bus. The vehicle identification plate serves for the exact identification of the converter. It is on the converter. There is about the exact type designation, the delivery date and the manufacturing number. With contacts with the company ELGO Electric GmbH is to be always used these data.



Note! The company ELGO Electric GmbH is not responsible for possible machine and/or personal injuries, which can result from incorrect material at the converter and follow-up electronics. The machine manufacturer is obligated to seize and accomplish suitable safety-relevant measures.

### 2.1 screening measures



The screen of the signal output cable should be attached only on one side to the following electronics and connected central with protective ground. The signal output cable is to be laid in principle separately from load current lines to and a safety margin from at least 0.5 m to inductive and capacitive interference sources such as contactor, relay, engines, switch power packs, clocked automatic controllers etc. is to be kept. If disturbances should arise despite adherence to all points described above, must be proceeded as follows:

- attach from RC elements over contactor coils of AC contactors (e.g. 0.1  $\mu$ F/100 W)
- attach from flywheeling diodes over DC inductances.
- attach from RC elements over the individual engine phases and over the exhaust brake (in the terminal box of the engine).
- protective ground and reference potential do not connect!

- connect a system filter at the external power pack

### 3. Assembly of the converter



The integrated assembly slots at the converter housing make a very simple and self-describing assembly possible from 3 sides. Here arbitrary M6 hexagonal screws can (according to DIN 933) or M6 square nuts (according to DIN 562) to be pushed in, around the system on to fasten the desired place. When a assembling at the top side. It is to be noted that the address attitude and the LED remain accessible.

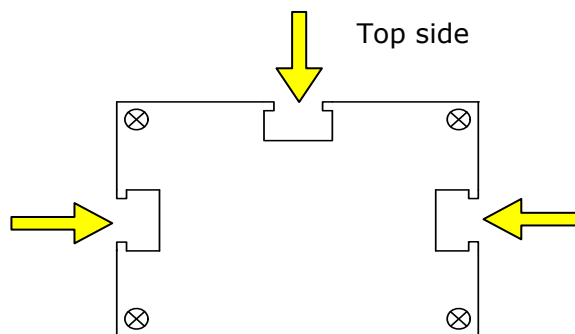

### 4. Operating parameter

At the housings top side a green LED (bus run) and a red LED (bus Fail) are attached for the announcement of the operating condition. To the address are attached likewise above two turning coding-switches adjust beside the LED's.

#### Green LED (Bus Run)

- on = ready for use
- off = no supply voltage
- flashes cyclically = Slave does not have a cyclic data exchange with PROFIBUS- DP- MASTER
- flashes irregularly = approach: missing or incorrect configuration running time: Host-Watchdog-time-error

#### Red LED (Bus Fail)

- on = not remediable converter - disturbance
- off = no error/ bus in the cycle
- flashing = Converter addressed by the master not

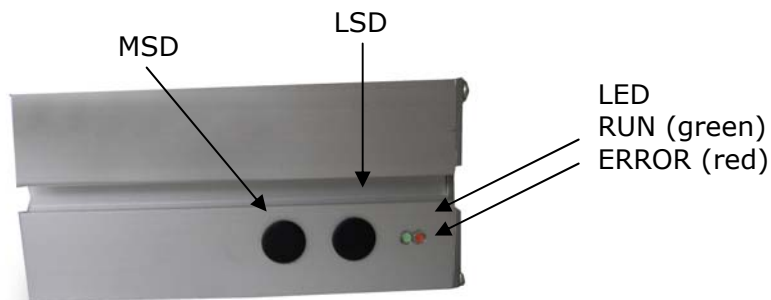

### Address attitude:

The address attitude is made with the 2 coding switches at the top side of housing. The decade with high order with the coding switch MSD and the low order decade with the coding switch LSD.

## 4.1 Attitudes

Over a GSD file the following parameters are adjustable. (GSD file is provided on disk)

Monoflop with	20... 255 $\mu$ s	[ 200 ]
number of clocks of SSI	18... 32	[ 24 ]
scaling SSI/x	1... 255	[ 1 ]
Offset	-1073741823... 1073741824	[ 0 ]
[ default value ]		

## 5. External dimensions

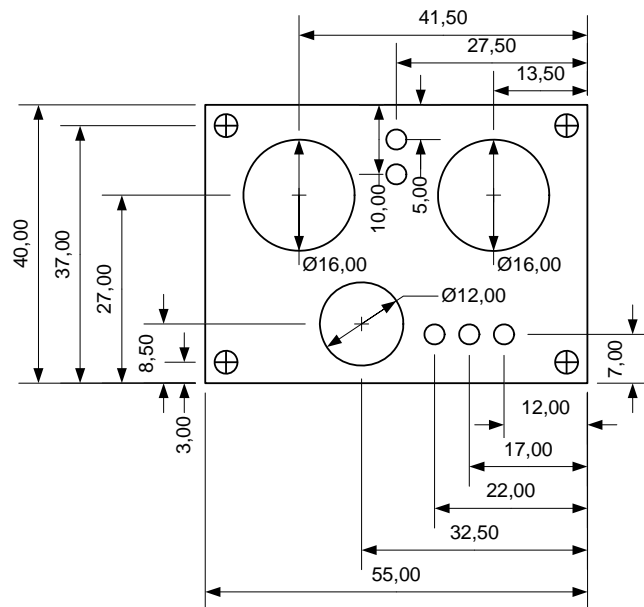
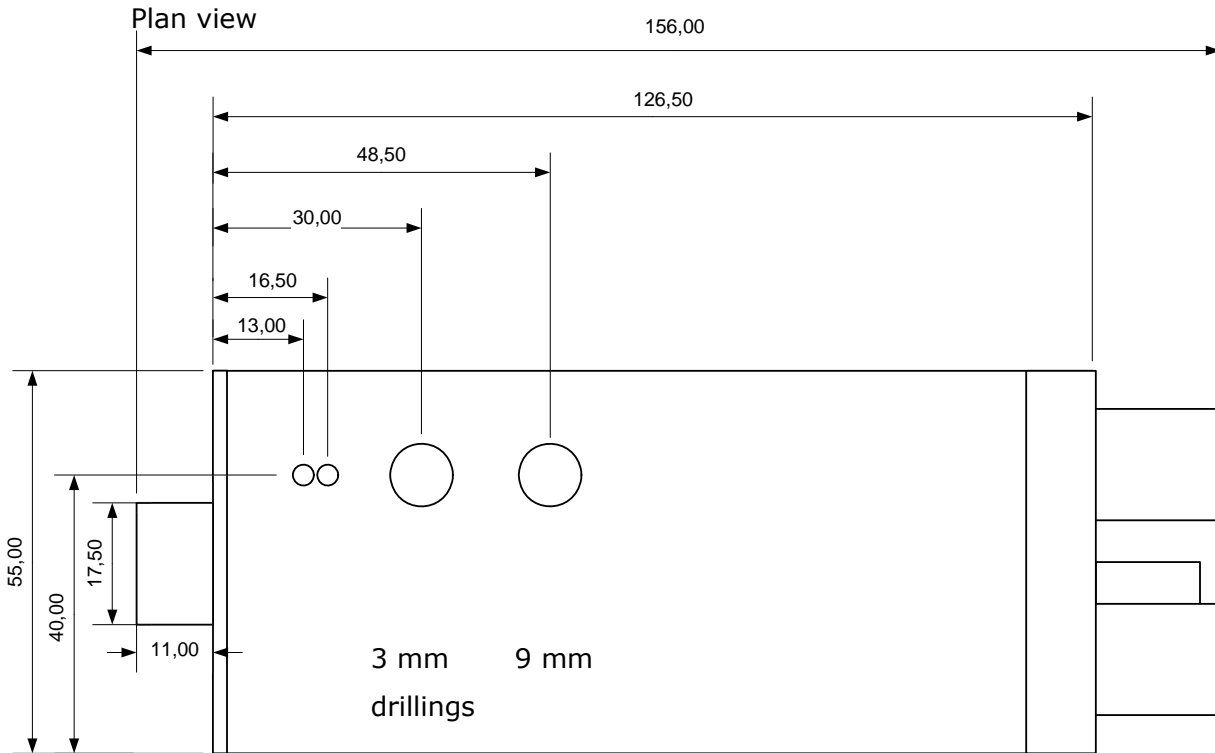

## 6. Interfaces and minutes

### 6.1 SSI - interface

Operational principle: If the clock is interrupted not for the time  $T_m - T/2$  (expenditure of further 25 periods), clocks the shift register again the same data value out (power have error recognition in the evaluation). Some give failure bit (PFB).

**Note: With the professional bus - converter should always be the PFB "LOW"!**

Data minutes: Selections of the data (2 times with 25 clocks)

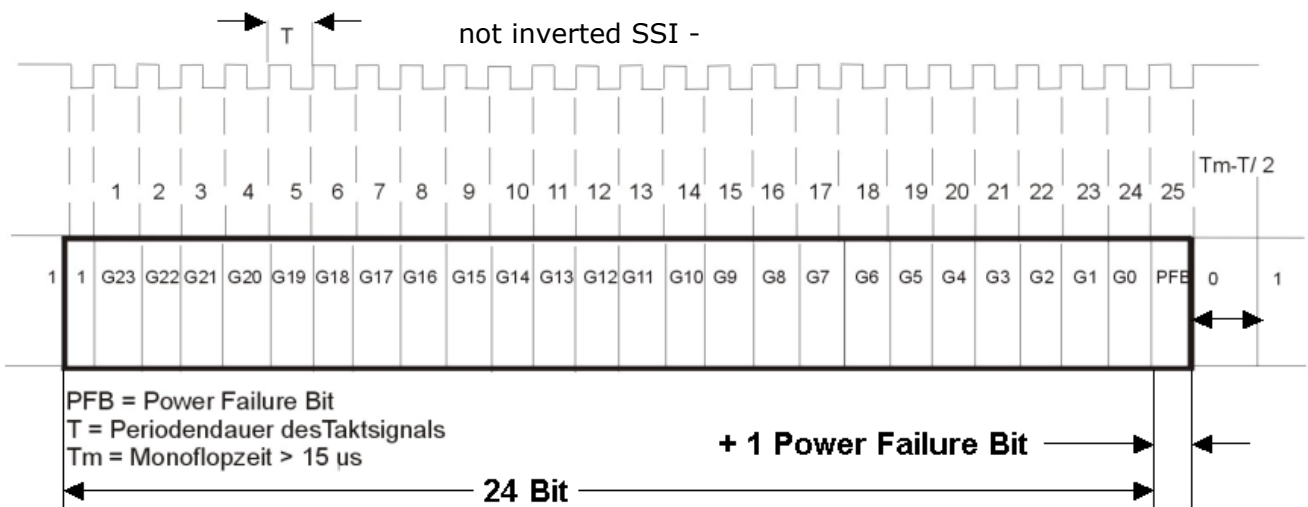

By means of at the top side of housing, under a protective plastic film, turning coding-switch present, the data format of the SSI interface between binary and Gray code can be switched.

position	code
0	binary
1	Gray

Connection allocations:

Round plug SSI plug (standard)	
Pin	function
1	0 V / GND
2	+ 24 VDC
3	Data -
4	Data +
5	Clock -
6	Clock +
7 & 8	N.C.

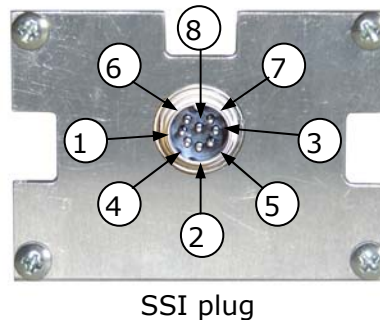

## 6.2 Profi-Bus interface

The converter is according to standard equipped with a professional bus interface after IEC61158/IEC61784. The following parameters are given:

Transmission: RS485 two-wire line  
 conduit length: 1200m with 9,6kBaud  
                   200m with 1,5Mbaud  
                   100m with 12Mbaud  
 Baud rate: 9,6kBaud to 12Mbaud (automatic recognition)  
 clock rate max. 250kHz  
 participant: max. 32 per segment (by Repeater on 126 expandable)  
                   mono and multi-masters of systems possible

Connection allocations:

Profibus IN (Flanged plug M12)	
Pin	Function
1	N.C.
2	Data A
3	N.C.
4	Data B
5	shield

Profibus OUT (Flanged box M12)	
Pin	Function
1	N.C.
2	Data A
3	N.C.
4	Data B
5	shield

Supply voltage (Flanged Plug M8)		
Pin	color	Function
1	brown	+19 bis 27 VDC
2	white	N.C.
3	blue	0V / GND
4	black	N.C.

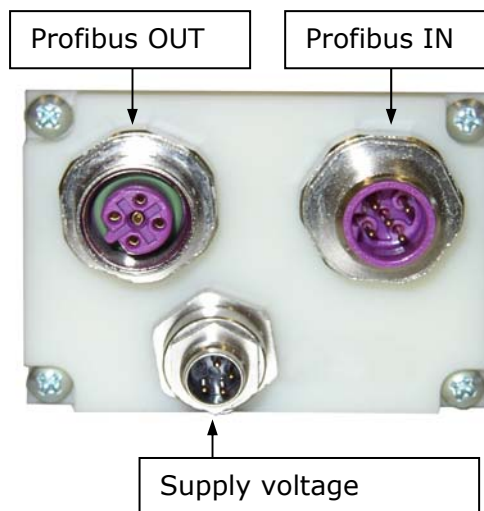

## 7. Technical data

measuring system	
operating voltage	19 ... 27 VDC
power input	max. 0,2 A
signal level	in accordance with interface specification
work temperature	0... + 60° C
operating temperature	- 20... + 70° C
storage temperature	- 40... + 85° C
air humidity	not condensing, max. 80 %
operating hight	max. 2000 m about N.N.
savity class system	IP 50: standard version IP 67: option V
housing	Aluminium (Al/Mg/Si 0,5)
dimensions	See dimensional drawing
conduit lenghts	Dependent on bit rate

## 8. Model code

PNO1	-	000	-	XX	-	X
------	---	-----	---	----	---	---

**type** \_\_\_\_\_  
SSI – Profibus Converter

**SN number** \_\_\_\_\_  
special unit number

**address** \_\_\_\_\_  
Work pre-setting of the address

**option** \_\_\_\_\_  
V = poured (IP 67)

order example:  
1 SSI- professional bus converter after ELGO standard preset address 6Ah,  
housing poured  
PNO1 - 000 - 6A - V

## 9. Accessories

Connection cable  
with M8 clutch, 4polig  
5m lenght

Art. Nr. 503000052



Profibus – signal line  
with M12 plug, 5polig, b- coded (manufactures on one side)  
5m lenght

Art. Nr. 503000050



with M12 clutch, 5polig, b- coded (manufactures on one side)  
5m lenght

Art. Nr. 503000051



with M12 plug/ clutch (double sided conected)  
5m lenght

Art. Nr. 503000054



Profibus – terminal resistance  
with M12 4polig, b- coded

Art. Nr. 503000053



## 10. Non- liability/warranty

We examined contents of this operating instructions carefully, after best knowledge and certain for agreement with the described hard and software. Nevertheless cannot be excluded errors, mistakes or deviations, so that we do not take over guarantee for the complete agreement. Necessary corrections are contained in the following editions.

For suggestions and improvement suggestions we are at any time extremely grateful.

Reproduction, duplication and translation, also in part, are permitted only by written permission of the company ELGO Electric GmbH. The company ELGO Electric GmbH is constantly endeavors their products to improve, therefore it reserves itself the right to technical changes without any announcement.

For possible errors or mistakes ELGO Electric does not take over adhesion.

The guarantee period amounts to 1 calendar year starting from delivery date and extends to the supplied equipment with all parts. They will in form carried out that defects at device/construction units, which developed as can be prove despite appropriate treatment and attention of the operating instructions, due to productions and/or material defects are free of charge exchanged or repaired after our choice.

As can be prove not damage due to inappropriate treatment, caused by ELGO Electric GmbH, e.g. creation wrong tension, penetration of liquids in the equipment inside, impact, scratch of the equipment front, chemical influences etc. are from any guaranteeing excluded!

Subject to change © ELGO Electric GmbH 2006

**ELGO - Electric - GmbH**  
**Measure - Control - Position**  
Carl - Benz - Straße 1, D-78239 Rielasingen  
phone.: 0049-7731/93 39 - 0, Fax: 2 88 03  
Internet: www.elgo.de, Mail: info@elgo.de

