

Series **AZ16E-302**



For Industrial Trucks

AZ16E-302 for industrial trucks

General: The AZ16E-302 conduces in combination with two sensors AZS as altitude indicator, e.g. in an industrial truck with two telescope syllabuses. At this unit the two sensors will be automatically cyclical elected and the sum of both positions ($H1 + H2$) is shown on the display. This is in accordance with the lift fork of the lift truck. The AZ16E-302 comprises a special software for that application.

Product Features:

- No reference run necessary
- Battery powered
- Absolute
- Retrofit
- Easy mountable
- Wearless
- Resistant against dirt
- Maximum measuring length 16m

Principle / Schematic Diagram

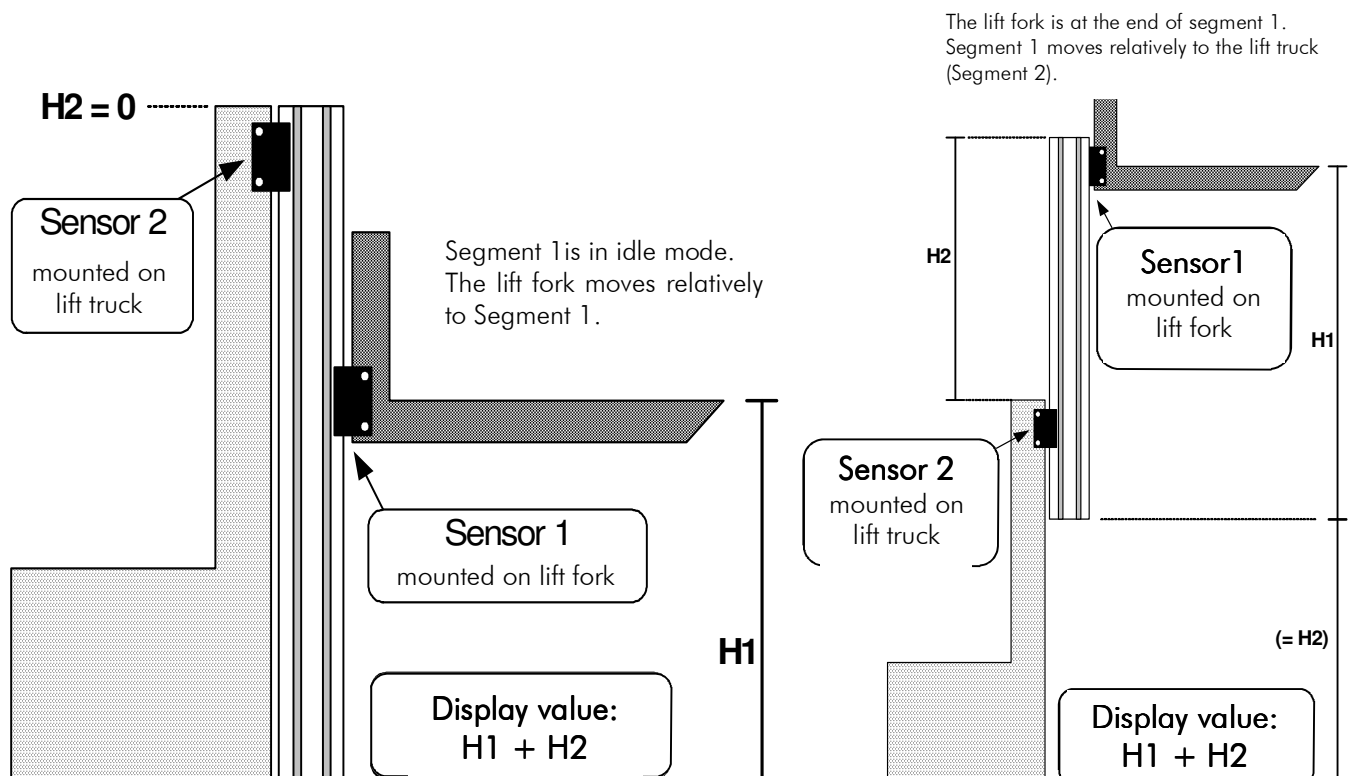

Technical specifications:

Power supply	1.5 V battery (size C)
Battery life span	1 ... 3 years (depends on adjusted switch on time)
Distance sensor/tape	Max. 1.5 mm
Resolution of sensor	0.1 mm
Measurement units	MM or INCH
Max. measuring distance	8 m
Max. length of sensor cable	20.0 m
Principle of measurement	Magnetic, absolute
Kind of measurement	Linear, no rotative tasks possible
LCD-Display	6 digits, height 8 mm, +sign, + battery condition
Keypad	Membrane keypad
Operation temperature	+5... +50°C
Stock temperature	0... 70°C
Humidity	Non condensing max. 80%
Protection class (indicator)	IP 43 installed state
Outer dimension (indicator)	B x H = 96 x 72 mm
Panel cut out	B x H = 93 x 67 mm
Depth AZ16 E incl. sensor connector	(depth) 47 mm (depth with connectors) 53 mm
Protection external Sensor	IP 67
Dimension external Sensor	See drawings

Dimensions:

External magnet sensor AZS

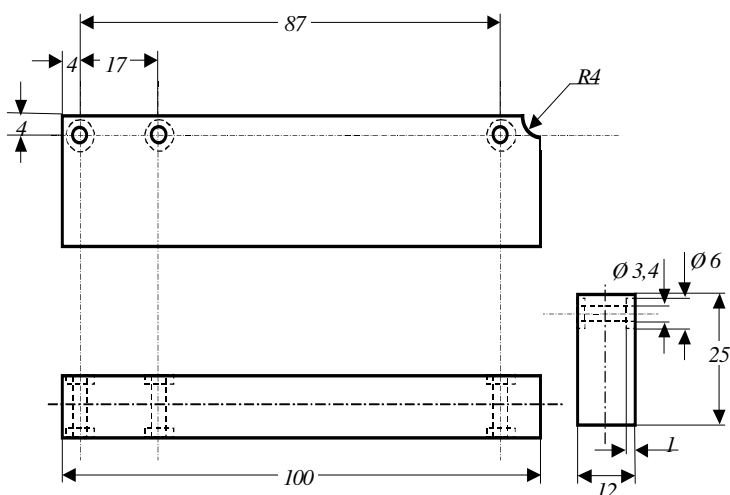

Order reference:

For orders, please use the following order code:

AZ16E - - -

A Version

302 = 3 Axes indicator
(Sensors AZS as accessories available)

B Supply

1 = 1x C sized battery internal

C Length of sensor cable

Standard Length: 1 m (see sensors AZS)

D Cable options

1 = pluggable via RJ45- plug

E Options

AG = Assembly Housing

For Example:

AZ16E - 302 - 1 - 01.0 - 1 - AG
A A A - B - C C C - D - E E

AZ16E-302, with supply through an internal C sized battery, 1 m Sensor cable, a RJ45-plug and with assembly housing.

Your Order:

AZ16E - - -

Dimensions Indicator

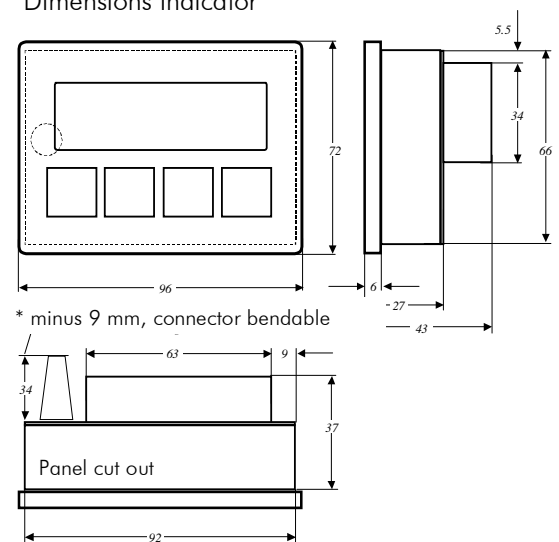

Order reference:

For orders, please use the following order code:

AZS - $\bar{A} \bar{A} \bar{A} - \bar{B} - \bar{C} \bar{C} . \bar{C} - \bar{D}$

A Version

- 000 Standard
- 001 First special version

B Sensor type

- 1 AZSensor-100 / for max. 8m measuring length

C Sensor cable length

- Standard length: 1 m
(further lengths for additional charge; max. 20 m)

D Cable options

- 1 Cable outlet with RJ45- plug (Standard)

For example:

AZS - $\underline{000} - \underline{1} - \underline{01.0} - \underline{1}$
A A A - B - C C.C - D

AZS Sensor ELGO Standard with Sensor for max. 8 m measuring lengths, 1.0 m Sensor cable and a cable outlet with a RJ45 connector.

Your Order:

AZS - $\bar{A} \bar{A} \bar{A} - \bar{B} - \bar{C} \bar{C} . \bar{C} - \bar{D}$

Accessories:

AB20-40-10-1-R-11 Magnetic tape, with 4.0 mm pole width and INOX-cover band.

